

**BULLETIN 310B
VOL 2**

**TECHNICAL MANUAL
33 TELETYPEWRITER SETS
KEYBOARD SEND-RECEIVE (KSR)
RECEIVE-ONLY (RO)
AUTOMATIC SEND-RECEIVE (ASR)**



**TELETYPE[®]
CORPORATION**
5555 TOUHY AVENUE, SKOKIE, ILLINOIS

310B
Volume 2

INTRODUCTION

Bulletin 310B is a technical manual that provides general and specific information about the 33 Keyboard Send-Receive (KSR), Receive-Only (RO), and Automatic Send-Receive (ASR) Teletypewriter Sets and their component units. It consists of two volumes.

Volume 1 contains a description of the 33 Teletypewriter Sets and gives installation instructions. Also included in Volume 1 is information on the disassembly and reassembly, lubrication, and principles of operation of the component units of the Teletypewriter Sets. Volume 2 includes adjustment information on all component units of 33 Teletypewriter Sets.

Each volume is made up of a group of appropriate independent sections. Each independent section is complete within itself—it is separately identified by a title and section number, and the pages are numbered consecutively.

Each individual section is identified by a 9-digit section number which appears at the top of each page of a section. The section number appears on the left corner of left-hand pages and on the right corner of right-hand pages. In addition, the section number on each page contains the suffix TC which identifies it as a Teletype Corporation section. All sections are placed in the technical manual in ascending numerical order.

To locate specific information, refer to the table of contents on the following page. In the first column, under "Equipment," find the name of the component unit or set in question. Move across the page to the second column and locate the title being sought. The applicable 9-digit section number can then be found in the third column. Turn to Page 1 of the applicable section, and the contents of that section will be found.

The sections comprising this bulletin are now stocked separately and may be individually ordered if the entire bulletin is not needed.

TABLE OF CONTENTS

FILING INSTRUCTIONS

1. The following filing instructions apply to changes sent to the field.
2. Asterisks (*) in the table of contents indicate changes.
3. When the issue of a section changes, replace the old issue with the attached new one.
4. In the case of addendums, turn to the affected section and follow the instructions on the first page of the attached addendum.
5. Replace the old table of contents with this new one.

<u>Equipment</u>	<u>Title</u>	<u>Section</u>	<u>Issue</u>
Keyboard	Adjustments	574-121-700TC	4*
Typing Unit	Adjustments	574-122-700TC	5*
Tape Reader	Adjustments	574-124-700TC	4*
Tape Punch	Adjustments	574-125-700TC	5*
Cover	Adjustments	574-126-700TC	1

33 KEYBOARD

ADJUSTMENTS

CONTENTS	PAGE
1. GENERAL	1
2. BASIC UNIT	5
BREAK keylever spring	12
Contact block spring	10
Contact wires	6
Contact wire spring	10
CTRL contact wire	8, 9
CTRL keylever spring	12
Distributor trip linkage	20, 21
HERE IS keylever spring	12
Keylever spring	11
Keylever springs (SPACE, BLOCK, hyphen, or O keytops)	13
Latchlever spring	19
Left shift contact wire	7
Nonrepeat lever spring	17
REPT keylever spring	12
Reset bail spring	14
Shift codebar spring	16
Spacebar spring	11
Universal lever spring	18
Universal link	5
Universal link spring	15

1. GENERAL

1.01 This section provides adjustment information for 33 keyboards which are mechanically reset by an H-plate and the distributor trip linkage shown in 2. 16 and 2.17. It is reissued to provide specific references to related sections and to make a few minor changes. Marginal arrows indicate the changes.

Note: Adjustment information for solenoid reset keyboards is found in Section 574-121-703TC.

1.02 In the adjustments covered in this section, location of clearances, position of parts, and point and angle of scale applications are

illustrated by line drawings. Requirements and procedures are set forth in the several texts that accompany the line drawings. Tools necessary to maintain 33 Teletypewriter Sets are shown in Maintenance Tools Section 570-005-800TC.

1.03 The sequence in which the adjustments appear is that which should be followed when a complete readjustment of the keyboard is undertaken. No single adjustment should be undertaken without first completely understanding the procedure and knowing the requirements. Therefore, read a procedure all the way through before making an adjustment or checking a spring tension.

Note: Disconnect the keyboard from any voltage source prior to inspection, minor repair, extensive maintenance, or a complete readjustment.

1.04 References to left, right, front, rear, etc consider the keyboard to be viewed from a position where the spacebar (Figure 3) faces up and the contact mechanism is located to the viewer's right.

1.05 When a procedure calls for using pry points or slots to make an adjustment, place a screwdriver between the points or in the slots and pry parts in the proper direction.

1.06 When the keyboard is removed from the subbase to facilitate the making of an adjustment and subsequently replaced, recheck any adjustments that may have been affected. Also, if parts are removed from the keyboard to facilitate the making of an adjustment, be sure that they are subsequently replaced. Recheck any adjustment that may have been affected by the removal of parts.

1.07 Related adjustments are listed with some of the adjustment texts and are primarily intended to aid in troubleshooting the equipment. As an example, suppose that in searching for a trouble it is discovered that Part (2) of CONTACT WIRES adjustment does not meet its requirement. Under Related Adjustment it is indicated that Part (2) of this adjustment is affected by Part (1). Check Part (1) to see if it is the basic

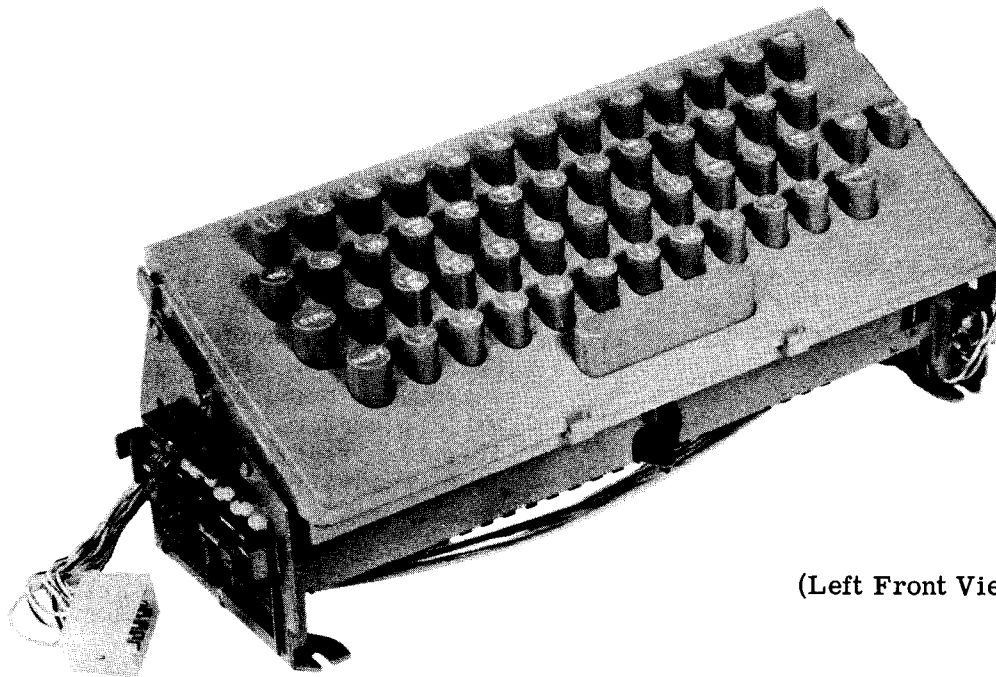

(Left Front View)

Figure 1 - 33 Keyboard (Parity)

cause of the trouble. Also, note that certain adjustments affect other adjustments. For example, see the DISTRIBUTOR TRIP LINKAGE adjustment. Note that this adjustment affects the TRIP LEVER ENGAGEMENT adjustment. (See Section 574-122-700TC.) If the former adjustment is changed, check the latter adjustment.

1.08 The spring tensions specified in this section are indications, not exact values. Therefore, to obtain reliable readings, it is important that spring tensions be measured by spring scales placed in the positions shown on pertinent line drawings. Springs that do not meet their requirements should be replaced by new ones. Only those springs that directly affect

the operation of the keyboard are measured, however, others may be measured indirectly in the process. If, at first, the spring tension requirement cannot be met, replace the indicated spring being directly measured. Then, if the requirement is not met, any springs that are indirectly measured in the procedure should be replaced, one at a time, with the performance of requirement checks each time a spring is replaced.

Note 1: Use only spring scales which are recommended by the manufacturer. These spring scales are listed in Maintenance Tools Section 570-005-800TC.

Note 2: The spring tensions may be checked in any sequence.

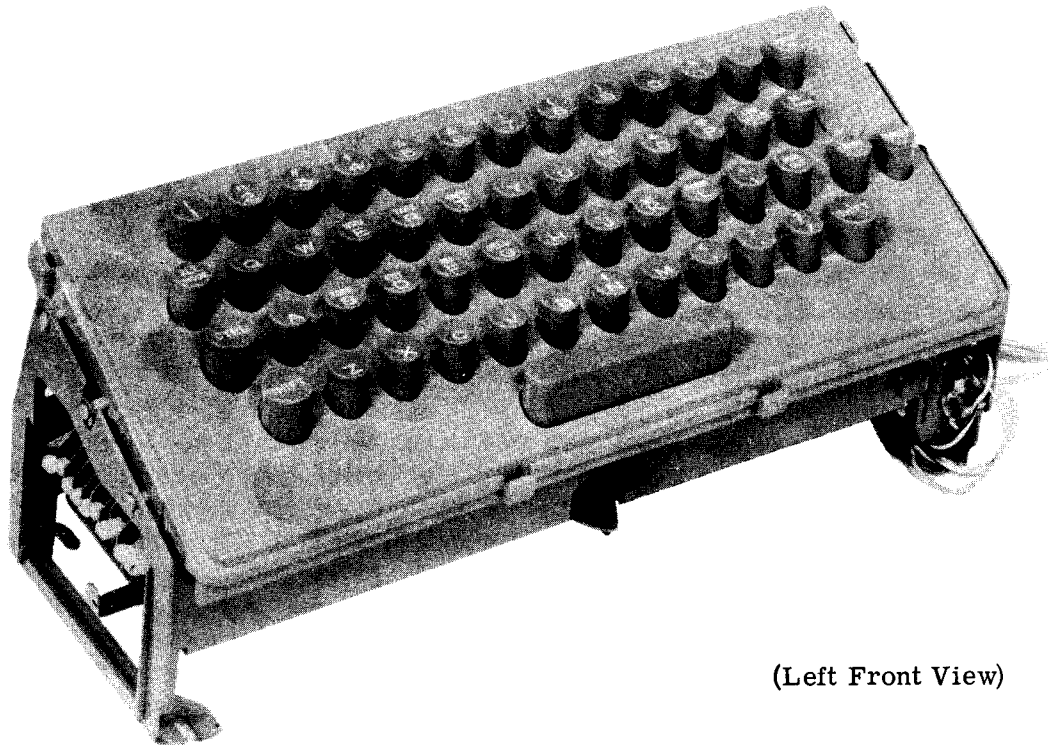

(Left Front View)

Figure 2 - 33 Keyboard (Nonparity)

1.09 With the keyboard and typing unit assembled together on the subbase, adjustment procedures may specify that the typing unit be placed in the stop condition. It is in the stop condition when the selector armature is in its attracted (frontward) position and all clutches are disengaged. Furthermore, when the typing unit is in the stop condition the keyboard will be latched — universal lever down and blocked from upward movement by an associated latch-lever.

Note: The keyboard is tripped when the universal lever is in its up position.

1.10 To place the typing unit in the stop condition, hold the selector armature in its attracted (frontward) position. Manually rotate the main shaft clockwise (as viewed from the left) until all clutches are in a stop position. Fully disengage all of the clutches by positioning a screwdriver to the associated stop-lug. Push the clutch disc in the normal direction of main shaft rotation until the corresponding latchlever seats in its clutch disc notch. This permits the clutch shoes to release their tensions on the clutch drum. With all clutches disengaged, the main shaft will turn freely without any dragging of the clutch shoes.

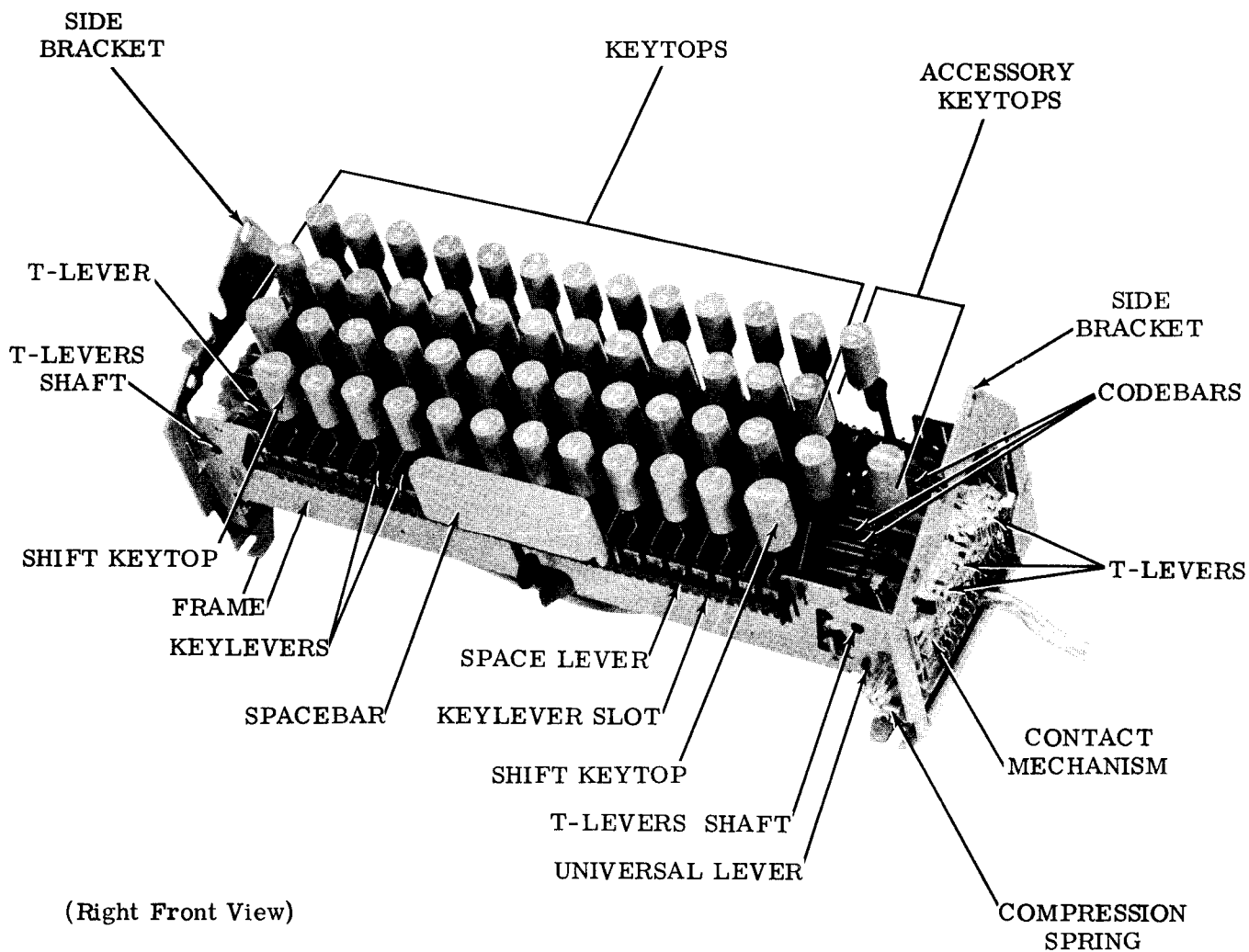

Figure 3 - Keyboard (Cover Removed)

Note 1: A stop position is that position where a shoe lever contacts a trip lever.

Note 2: The distributor clutch will not disengage unless the keyboard is latched and the answer-back drum is in its home position. The answer-back home position is the position where the control lever is fully detented into the indent on the answer-back drum.

1.11 A clutch is tripped by moving a trip lever up and away from contact with a shoe lever. When moved up, a trip lever no longer holds a shoe lever in its stop position. When the clutch is tripped, the shoe lever and a stop-lug on the clutch disc move apart, and the clutch becomes engaged. The clutch shoes wedge against the drum so that when the shaft is turned the clutch assembly will turn in unison with it.

2. BASIC UNIT

2.01 Universal Link

Note: Remove keyboard and call control unit from subbase to facilitate the making of the following adjustments. For disassembly instructions, refer to Section 574-121-702TC.

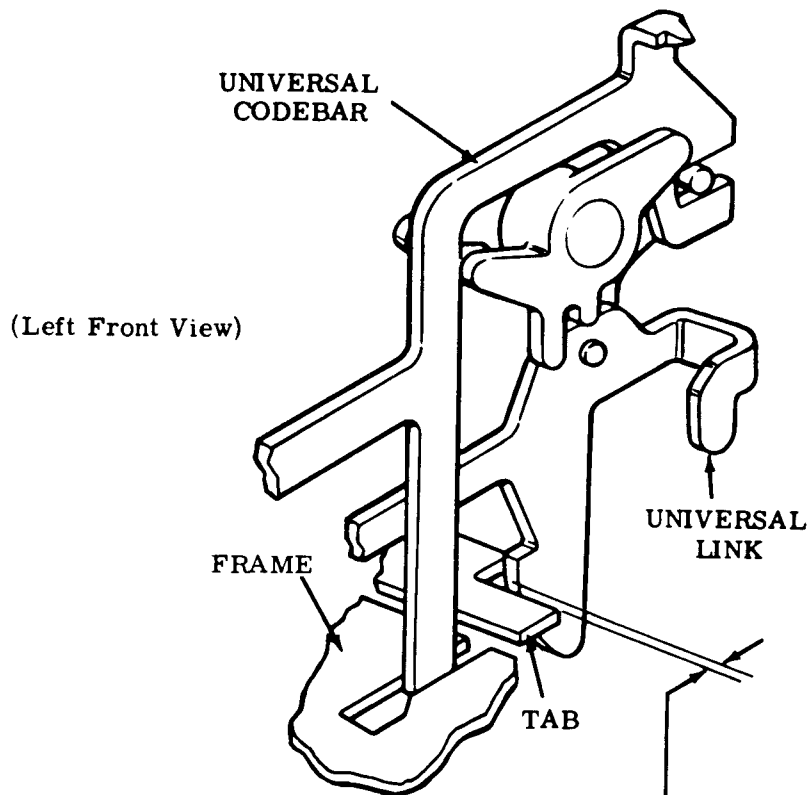

UNIVERSAL LINK

To Check

Push universal lever down until latched by latchlever.

Requirement

Min 0.089 inch---Max 0.103 inch
between universal link and frame.

To Adjust

Place screwdriver through opening in front of frame and bend tab.

2.02 Contact Wires

CONTACT WIRES

Note: Part (1) of this adjustment applies to contact wires actuated by the reset bail (contact block slots B through O). Part (2) applies to contact wires which have two camming surfaces and are operated by a T-lever and the reset bail.

(1) To Check

Push universal lever down until latched by latchlever. Place T-levers down in marking position. As each contact wire is checked, take up its play in an upward direction.

Requirement

Min 0.012 inch --- Max 0.027 inch between the first reset bail actuated contact wire located towards the front of the keyboard and its associated terminal.

Min 0.018 inch --- Max 0.032 inch between the remaining marking contact wires and their associated terminals.

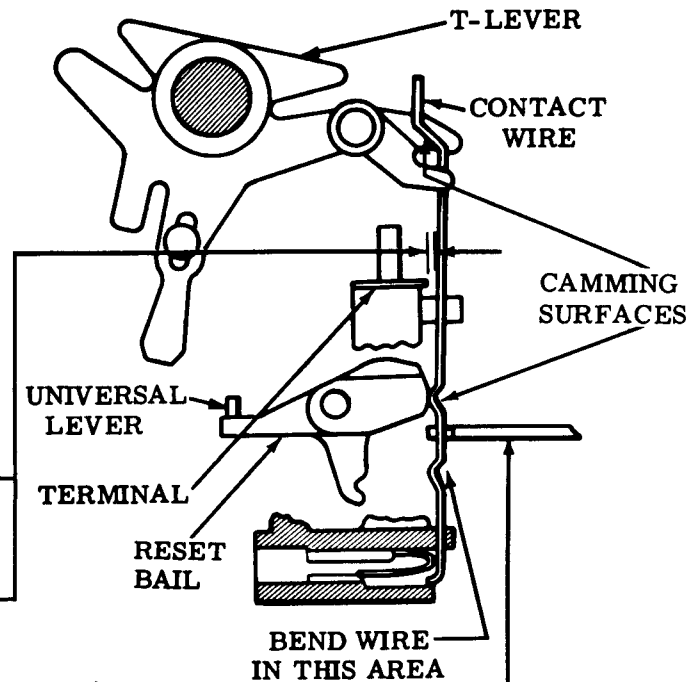

To Adjust

Bend contact wire with TP185829 bending tool.

Note: Contact bounce is not permissible during distributor readout of the nos. 1 through 8 code bits. If necessary, the no. 1 contact gap should be refined to the low end of its adjustment range to eliminate bounce.

(2) To Check

Push universal lever down until latched by latchlever. Place T-levers up in spacing position. Trip keyboard by depressing universal codebar. As each contact wire is checked, take up its play in an upward direction.

Requirement

Min 0.020 inch --- Max 0.040 inch between terminal and each contact wire.

To Adjust

Bend contact wire with TP185829 bending tool as shown.

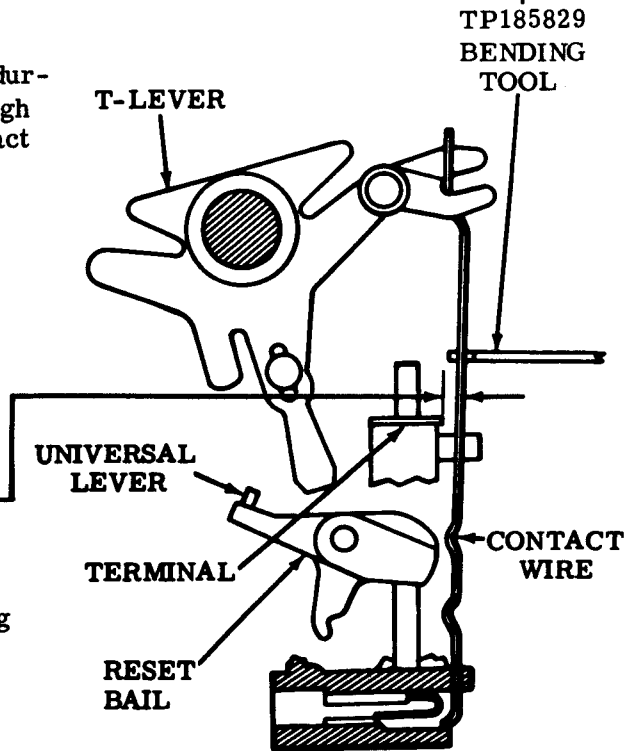

Related Adjustment

Affected by

Part (2) of this adjustment is affected by Part (1).

2.03 Contact Wires (continued)

LEFT SHIFT CONTACT WIRE

Note 1: This adjustment applies only to parity keyboards equipped with a TP180076 T-lever at right side of SHIFT codebar mechanism.

Note 2: Contact wires on auxiliary contact block on left side of parity keyboards are designated A, B, C, and D from rear to front.

(1) To Check

Push universal lever down, until latched by latchlever. Trip keyboard by depressing universal codebar. Insert a 0.090 inch gauge diagonally into third keylever (SHIFT) slot in frame from left. Depress left SHIFT keylever until it bottoms on top of gauge.

Requirement

- (a) Min some clearance between D contact wire and camming surface of its associated T-lever.
- (b) Min 0.020 inch---Max 0.055 inch between C contact wire and SHIFT terminal.

(2) To Check

Push universal lever down until latched by latchlever. Hold right SHIFT keylever fully depressed. Trip keyboard by depressing universal codebar. Release SHIFT keylever. Lightly take up play in contact block towards right.

Requirement

- (a) Min 0.004 inch between C contact wire and camming surface of SHIFT T-lever with all contact block play lightly taken up toward right.
- (b) Min 0.015 inch between D contact wire and SHIFT terminal.
- (c) Min 0.025 inch between C contact wire and rear SHIFT codebar at closest point of travel.

To Adjust

Bend contact wire(s) using TP185829 bending tool.

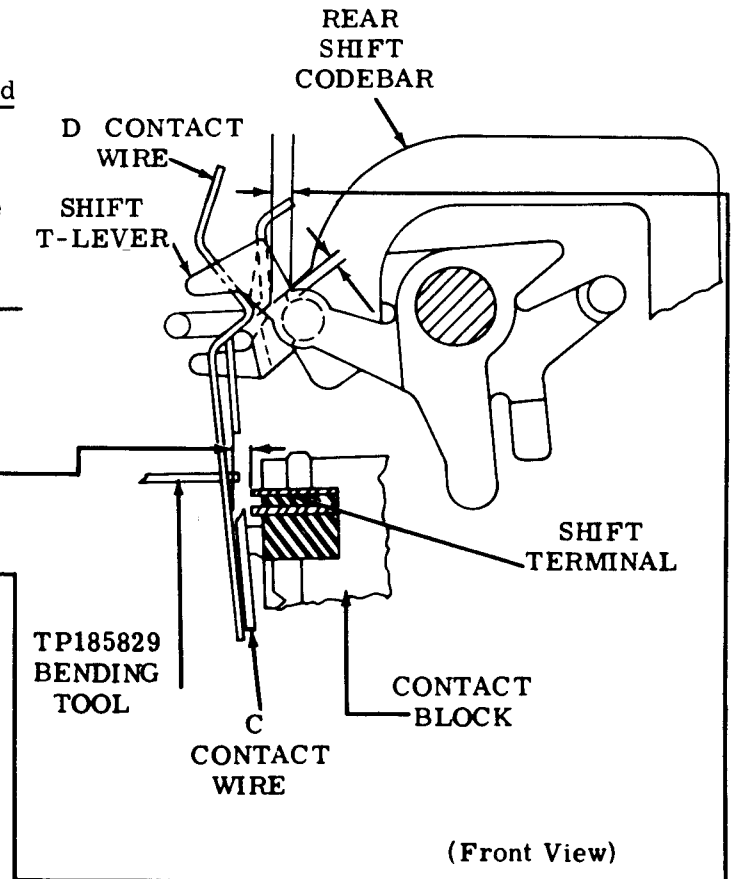
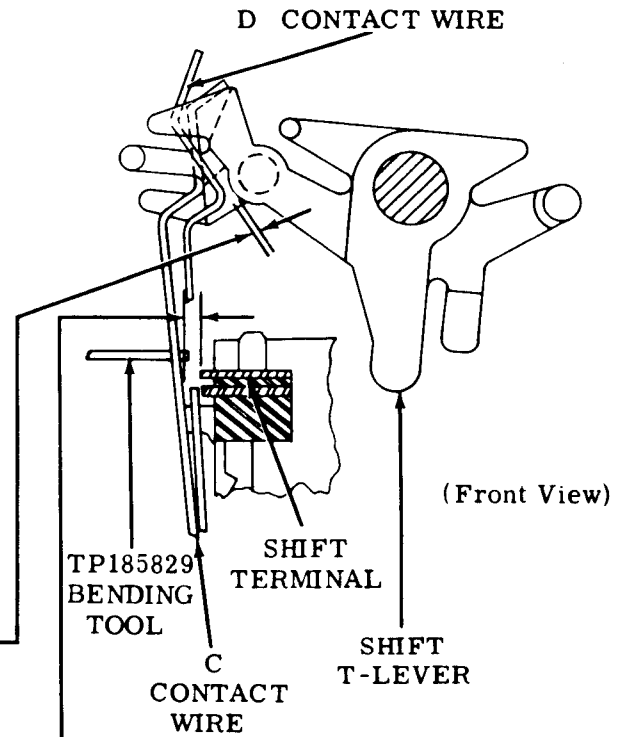

2.04 Contact Wires (continued)

"CTRL" CONTACT WIRE

Note 1: This adjustment applies only to parity keyboards equipped with TP185780 CTRL keylever spring but without TP186049 blocking lever and TP186051 tie link.

Note 2: Contact wires on auxiliary contact block on left side of parity keyboards are designated A, B, C, and D from rear to front.

(1) To Check

With the CTRL keytop unoperated, lightly take up play in contact block towards left to make clearance between the B contact wire and CTRL terminal a minimum. Check Requirement (a). Lightly take up play in contact block towards right to make clearance between B contact wire and CTRL terminal a maximum. Check Requirement (b).

(2) To Check

Fully depress the CTRL keytop and hold it depressed. Lightly take up play in contact block towards left to make clearance between the A contact wire and CTRL terminal a minimum. Check Requirement (c). Lightly take up play in contact block towards right to make clearance between A contact wire and CTRL terminal a maximum. Check Requirement (d).

Requirement

(a) Min 0.008 inch
between B contact wire and CTRL terminal.

(b) Max 0.050 inch
between B contact wire and CTRL terminal.

(c) Min 0.008 inch
between A contact wire and CTRL terminal.

(d) Max 0.050 inch
between A contact wire and CTRL terminal.

To Adjust

Bend contact wire(s) with TP185829 bending tool as shown.

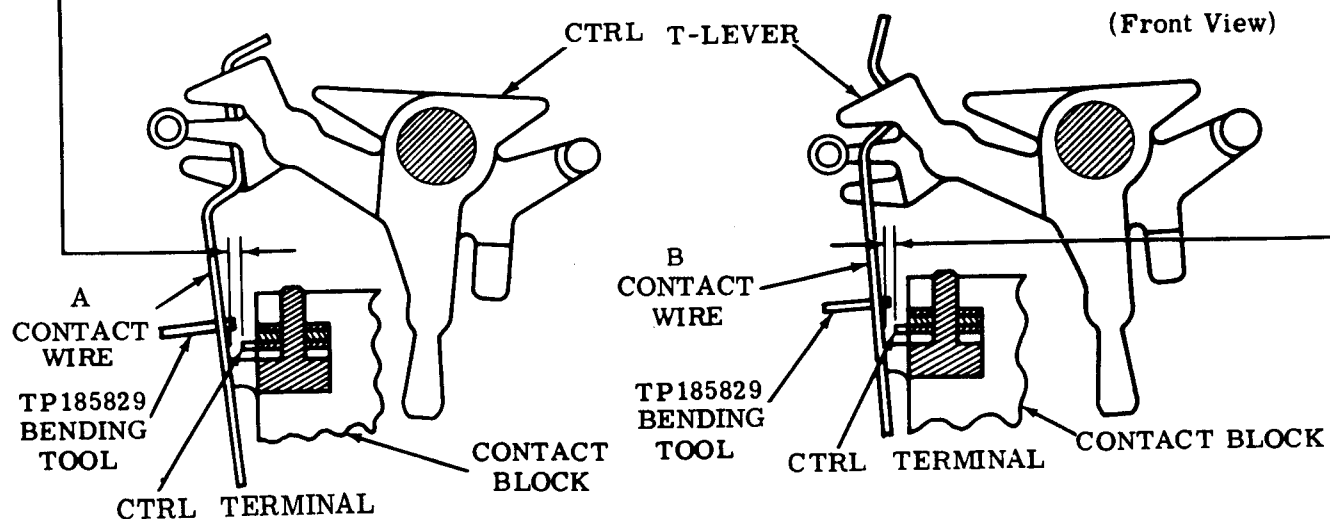

2.05 Contact Wires (continued)

"CTRL" CONTACT WIRE

Note 1: This adjustment applies only to parity keyboards equipped with TP185780 CTRL key-lever spring and with TP186049 blocking lever and TP186051 tie link.

Note 2: Contact wires on auxiliary contact block on left side of parity keyboards are designated A, B, C, and D from rear to front.

(1) To Check

Fully depress the CTRL keytop and hold it depressed. Trip keyboard by depressing the "Q" keytop. Release both keytops and manually reset the keyboard. Lightly take up all play in contact block towards the left.

Requirement

Min 0.023 inch---Max 0.035 inch
between B contact wire and CTRL terminal.

(2) To Check

Fully depress the CTRL keytop and then trip the keyboard. Release the CTRL keytop. Lightly take up all play in contact block towards the left.

Requirement

Min 0.015 inch---Max 0.030 inch
between A contact wire and CTRL terminal.

To Adjust

Bend contact wire(s) with TP185829 bending tool as shown.

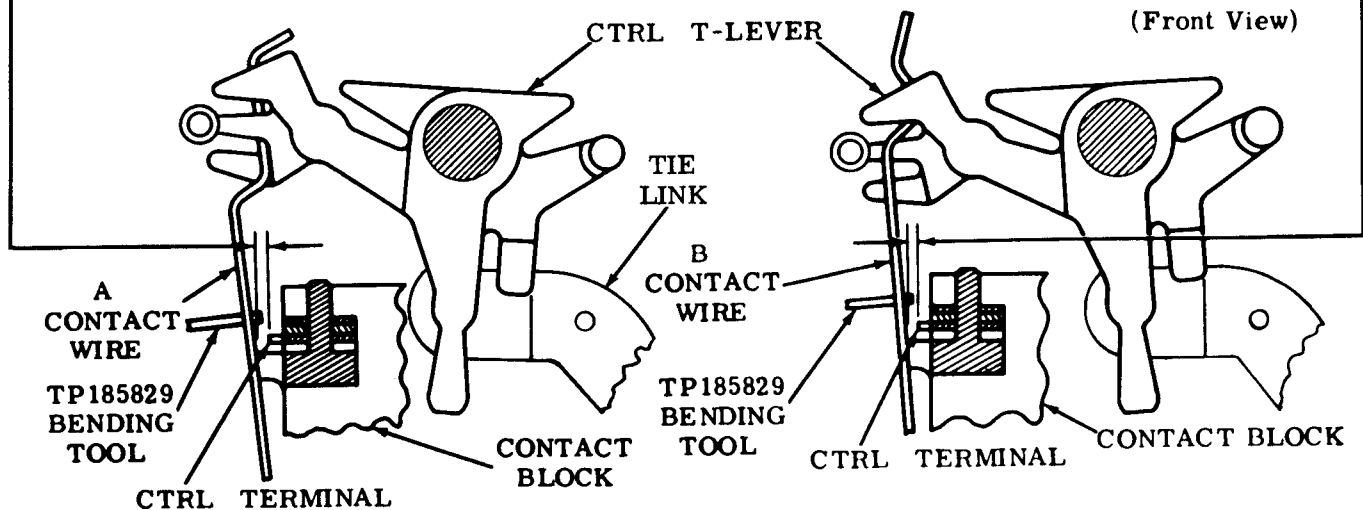

2.06 Contact Block Spring and Contact Wire Spring

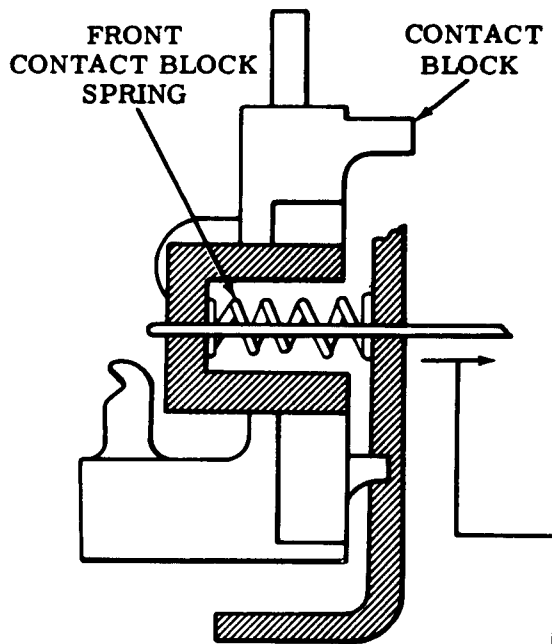

(Front View)

CONTACT BLOCK SPRING

Requirement

Min 18 oz---Max 42 oz
to start contact block moving.

Note: Check both front and rear contact block springs.

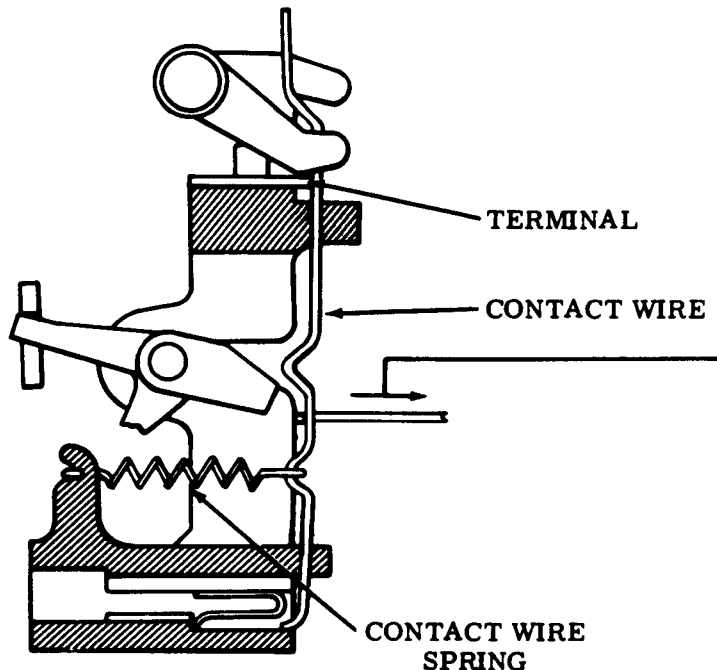

(Front View)

CONTACT WIRE SPRING

To Check

Push universal lever down until latched by latchlever. Place T-levers down in marking position. Trip keyboard by depressing universal codebar.

Requirement

Min 3/4 oz---Max 1-1/4 oz
to start each contact wire moving away from terminal.

2.07 Spacebar Spring and Keylever Spring

Note: The SPACEBAR SPRING and KEYLEVER SPRING adjustments do not apply to keylever springs associated with the SPACE, BLOCK, hyphen, or O keytops found on numeric-type keyboards.

SPACEBAR SPRING

To Check

Push universal lever down until latched by latchlever. Depress spacebar and then release.

Requirement

Min 5 grams---Max 25 grams to start spacebar moving.

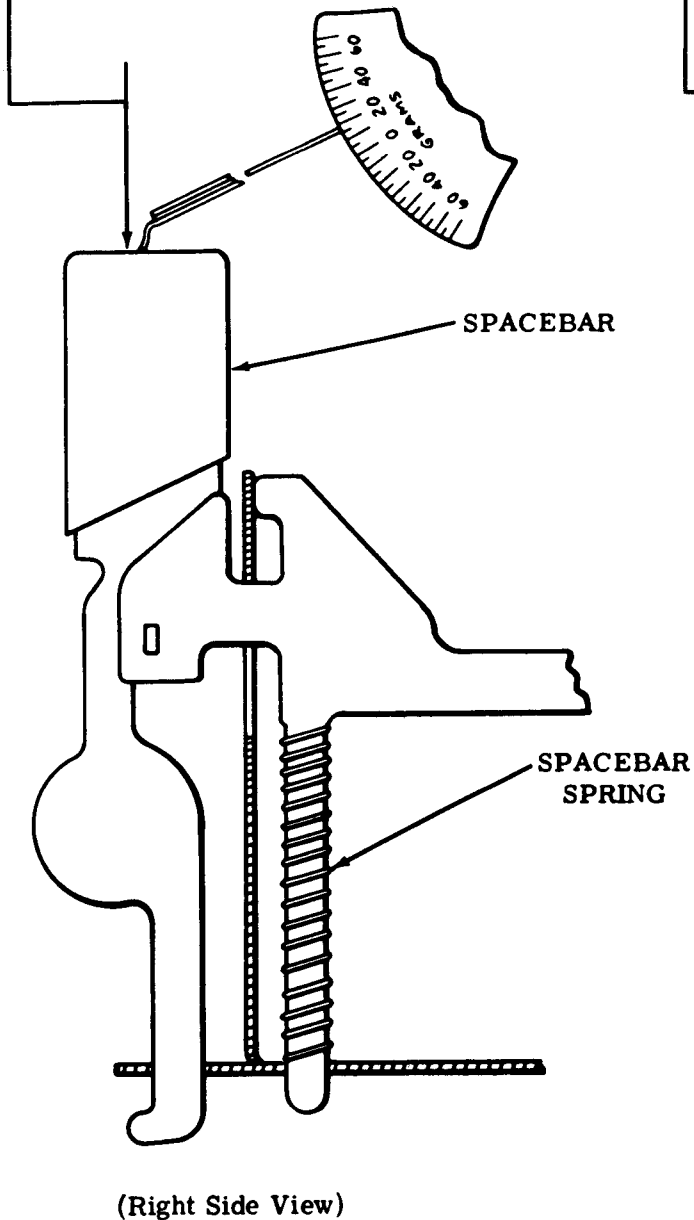

KEYLEVER SPRING

To Check

Push universal lever down until latched by latchlever. Select any keytop and depress. Release keytop.

Requirement

Min 5 grams---Max 30 grams to start selected keytop moving.

Note: Check each keylever spring.

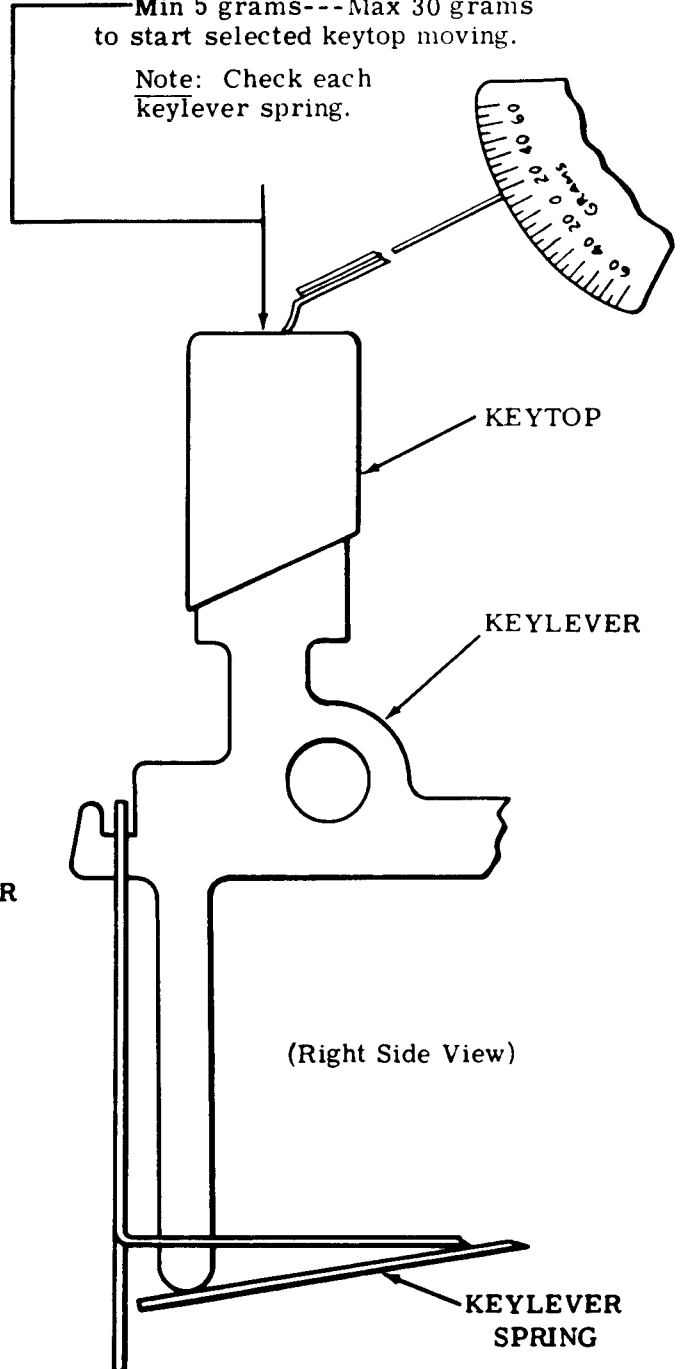

2.08 HERE IS, BREAK, CTRL, and REPT Keylever Springs

"BREAK" KEYLEVER SPRING

Requirement
Min 4-1/2 oz---Max 10 oz
to start keytop moving.

"CTRL" KEYLEVER SPRING

Requirement
Early design keyboards equipped with TP180102
keylever spring:
Min 1-1/2 oz---Max 3-1/2 oz
to start keytop moving.

Late design keyboards equipped with TP185780
keylever spring:
Min 4-1/2 oz---Max 6-1/2 oz
to start keytop moving.

"HERE IS" KEYLEVER SPRING

Requirement
Min 18 grams---Max 35 grams
to start keytop moving.

"REPT" KEYLEVER SPRING

Requirement
Min 15 grams---Max 30 grams
to start keytop moving.

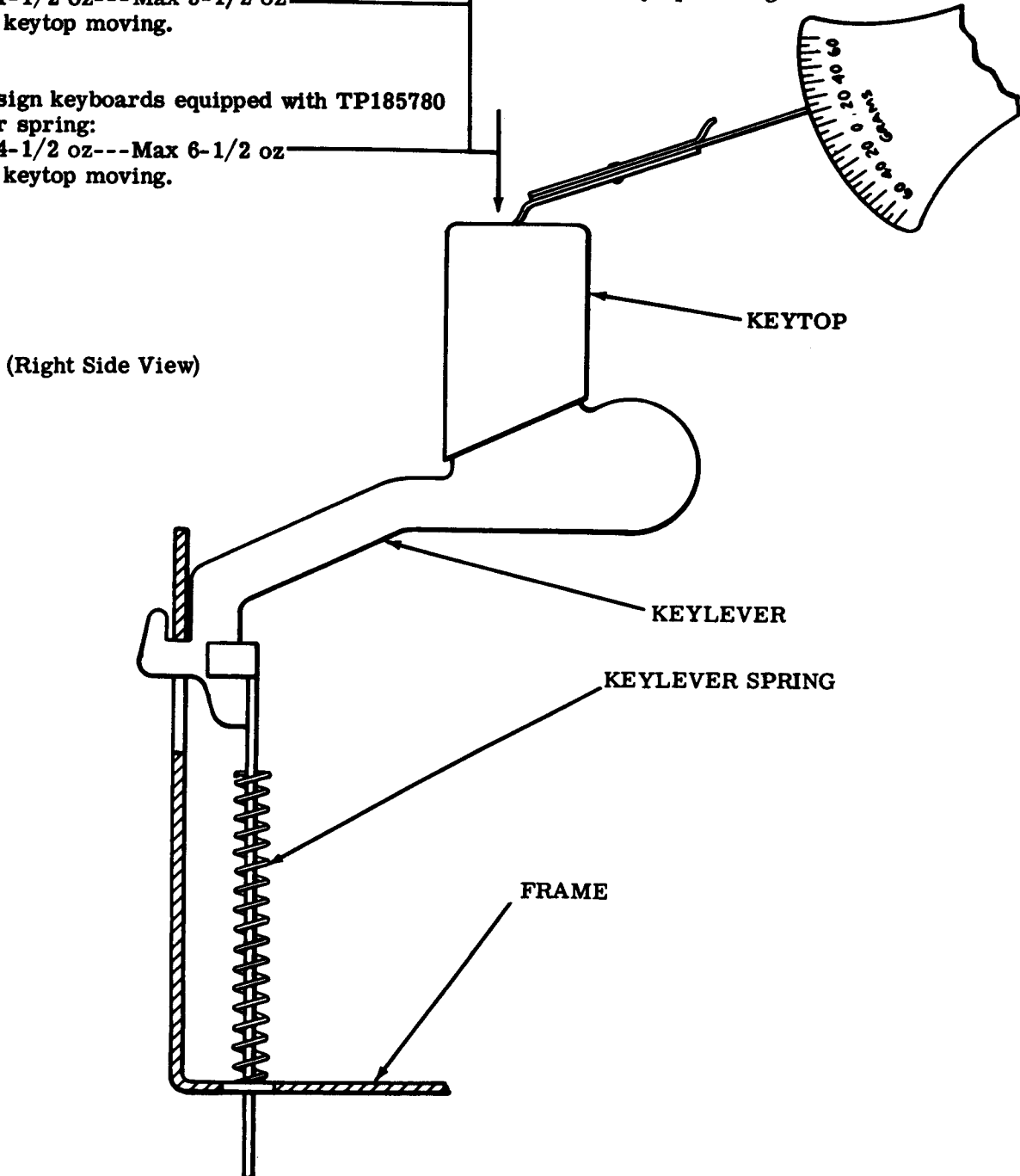

2.09 SPACE, BLOCK, Hyphen, or O Keylever Springs

KEYLEVER SPRINGS (SPACE, BLOCK, HYPHEN, O KEYTOPS)

Note 1: This adjustment applies only to keylever springs associated with SPACE, BLOCK, hyphen, or O keytops found on numeric-type keyboards.

To Check

Push universal lever down until latched by latchlever. Depress either the SPACE, BLOCK, hyphen, or O keytop. Release selected keytop.

Requirement

Min 20 grams---Max 65 grams
to start selected keytop moving.

Note 2: Repeat above procedure for each of the SPACE, BLOCK, hyphen, and O keytops.

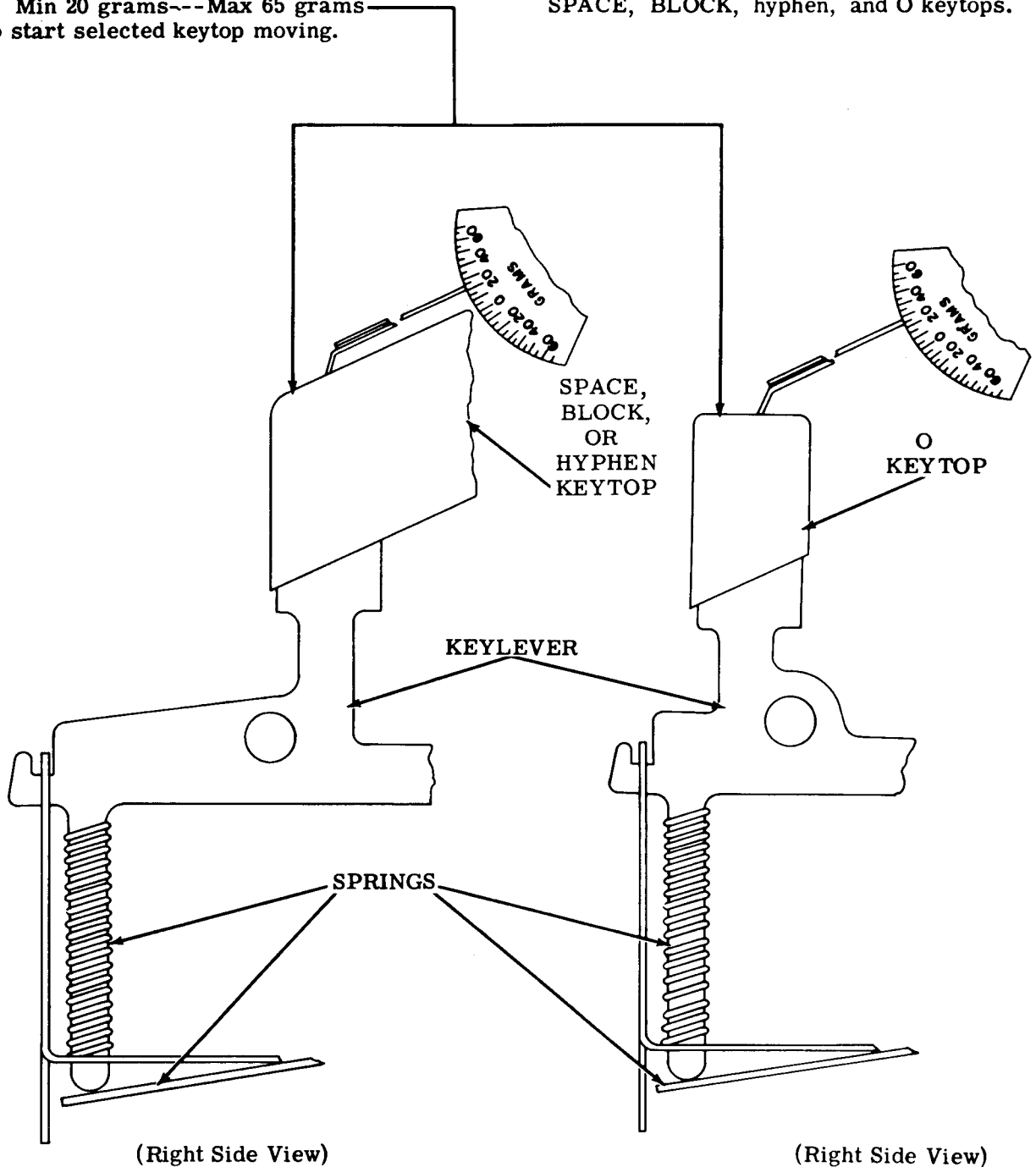

2. 10 Reset Bail Spring

RESET BAIL SPRING

To Check

Push universal lever down until latched by latchlever. Trip keyboard by depressing RUB-OUT keytop.

Requirement

Min 1-1/4 oz---Max 2-1/2 oz
to start reset bail moving.

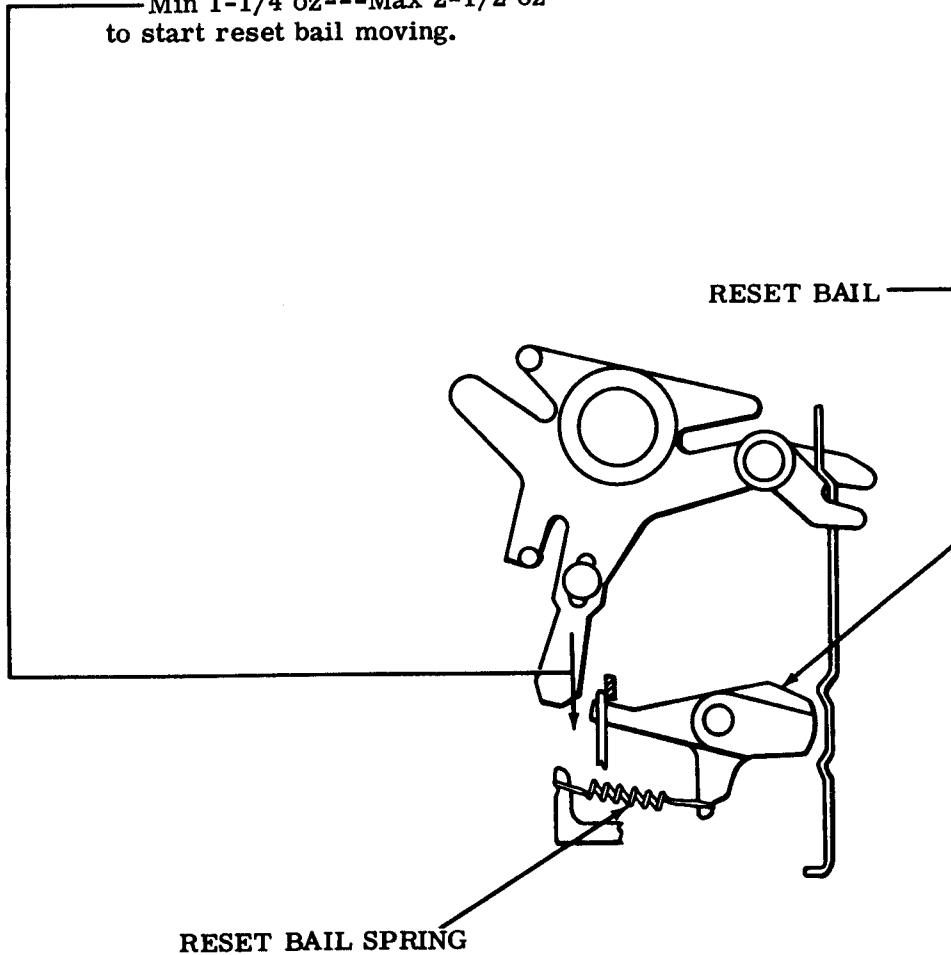

(Front View)

2.11 Universal Link Spring

UNIVERSAL LINK SPRING**To Check**

Push universal lever down until latched by latchlever. Trip keyboard by depressing universal codebar.

Requirement

Min 1/2 oz---Max 1-1/4 oz
to start universal link moving.

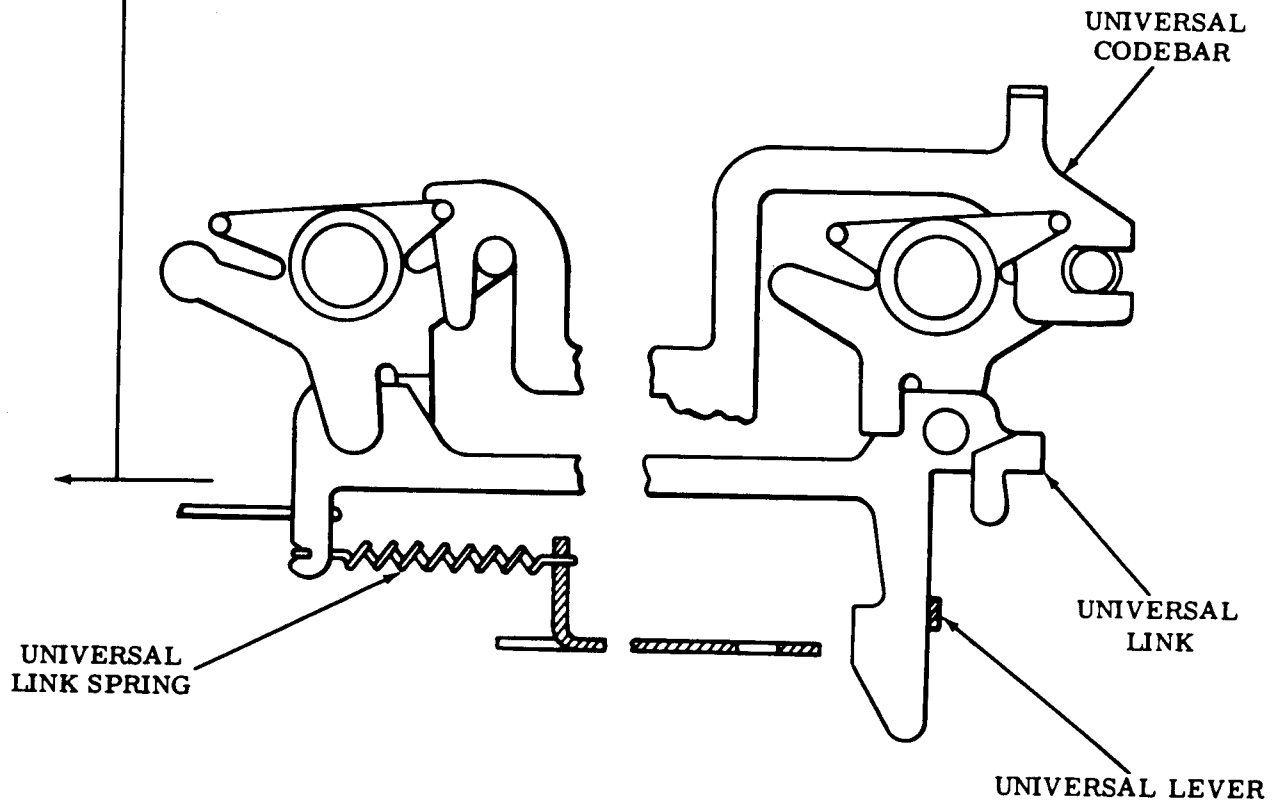

(Front View)

2. 12 Shift Codebar Spring

SHIFT CODEBAR SPRING

Requirement

Nonparity keyboards.

Min 1-1/4 oz---Max 2-1/2 oz
to start shift codebar tie link moving.

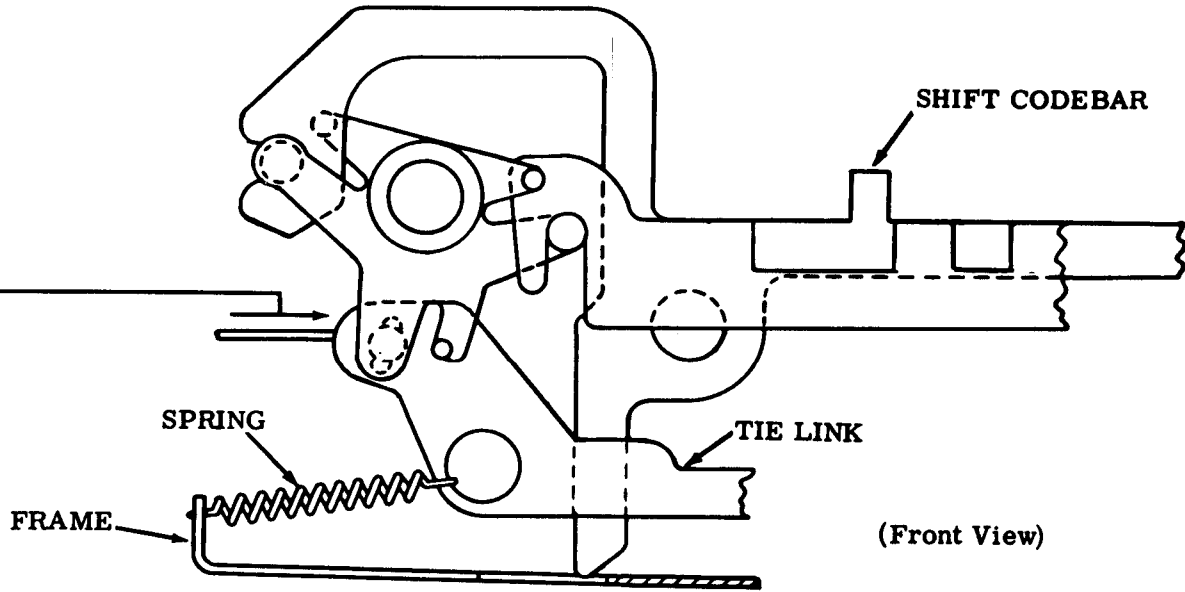

Parity keyboards:

Min 2 oz---Max 3-3/4 oz
to start shift codebar tie link moving.

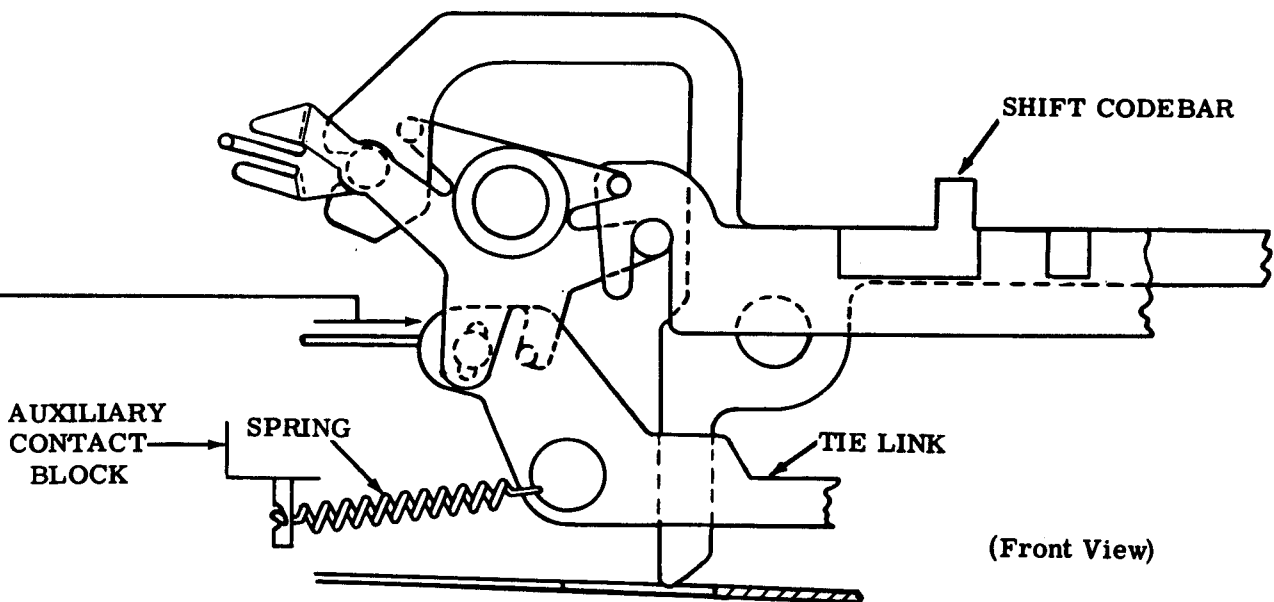

2. 13 Nonrepeat Lever Spring

Note: Remove keyboard cover. For disassembly instructions, see Section 574-121-702TC.

NONREPEAT LEVER SPRING**To Check**

Push universal lever down until latched by latchlever.

Requirement

Min 1/4 oz---Max 3/4 oz
to start nonrepeat lever moving.

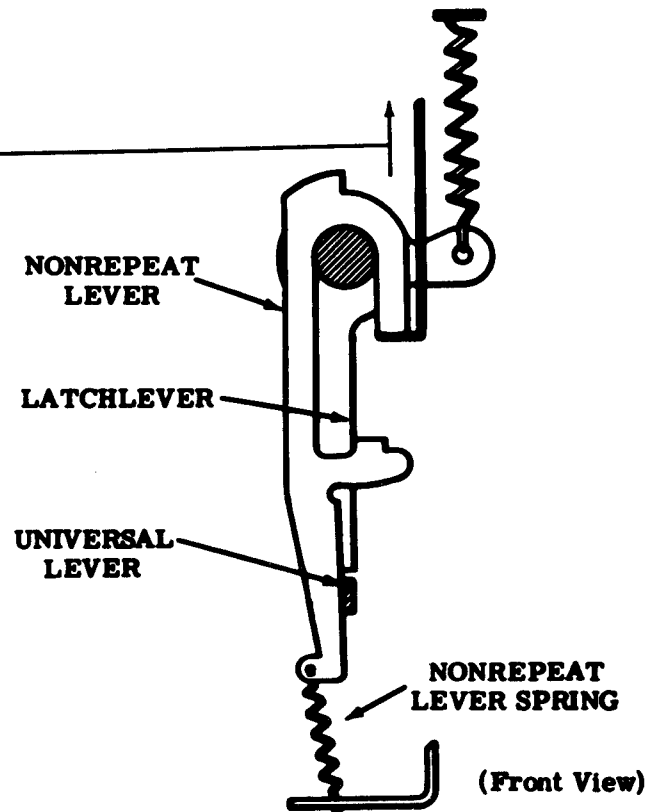

2. 14 Universal Lever Spring

UNIVERSAL LEVER SPRING

To Check

Push universal lever down until latched by latchlever. Hold reset bail away from universal lever.

Requirement

Min 1/2 oz---Max 1-1/2 oz
to start universal lever moving.

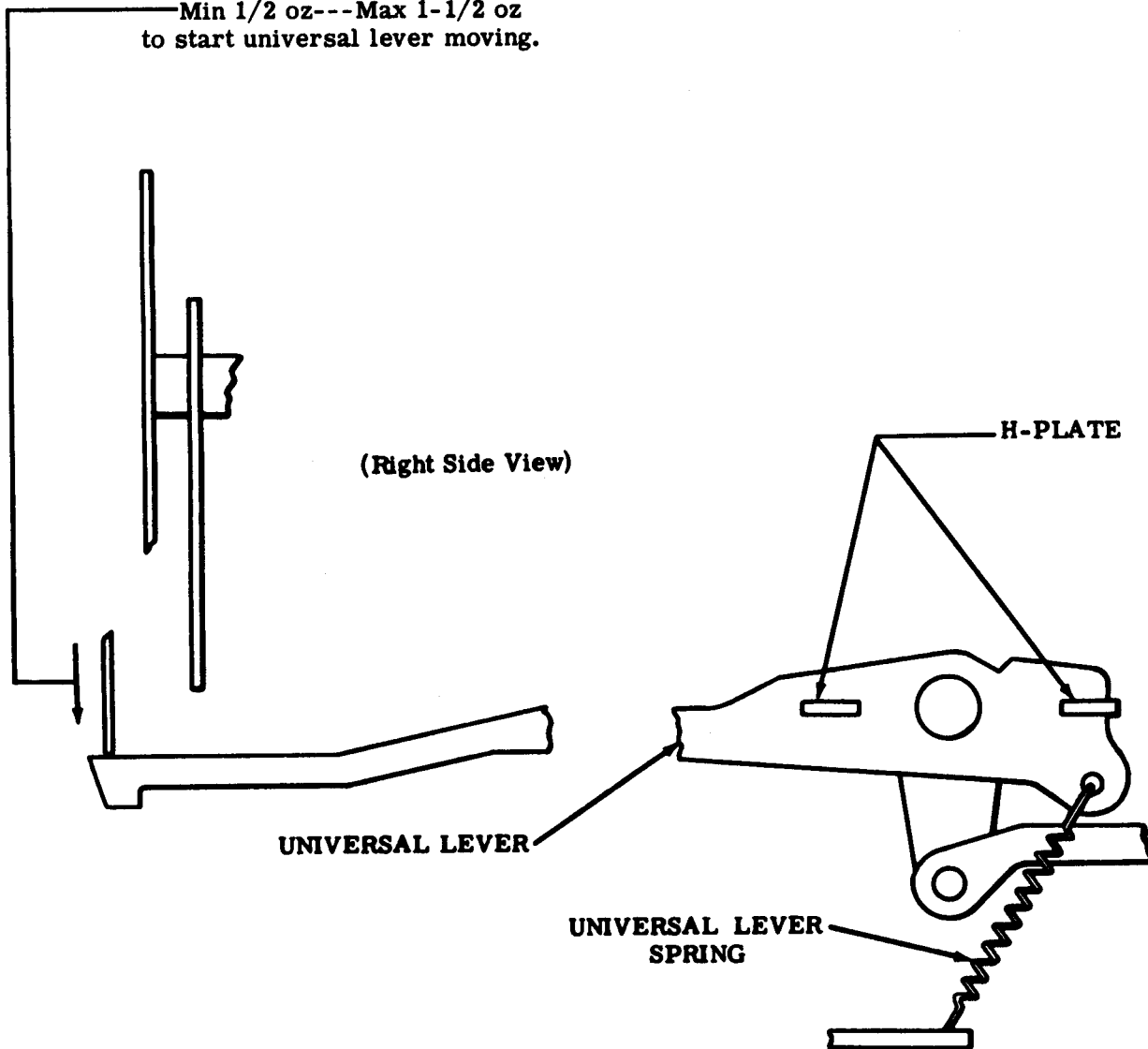

Note: Replace keyboard cover and reassemble keyboard (including H-plate) onto subbase. For reassembly instructions, see Section 574-100-702TC.

2.15 Latchlever Spring

LATCHLEVER SPRING

To Check

Place typing unit in stop condition. Trip distributor clutch and rotate main shaft until keyboard follower lever is moved by cam roller to its lowest point.

Requirement

Min 1/2 oz---Max 1 oz
to start latchlever moving.

Note: Replace call control unit onto subbase. For reassembly instructions, see Section 574-100-702TC.

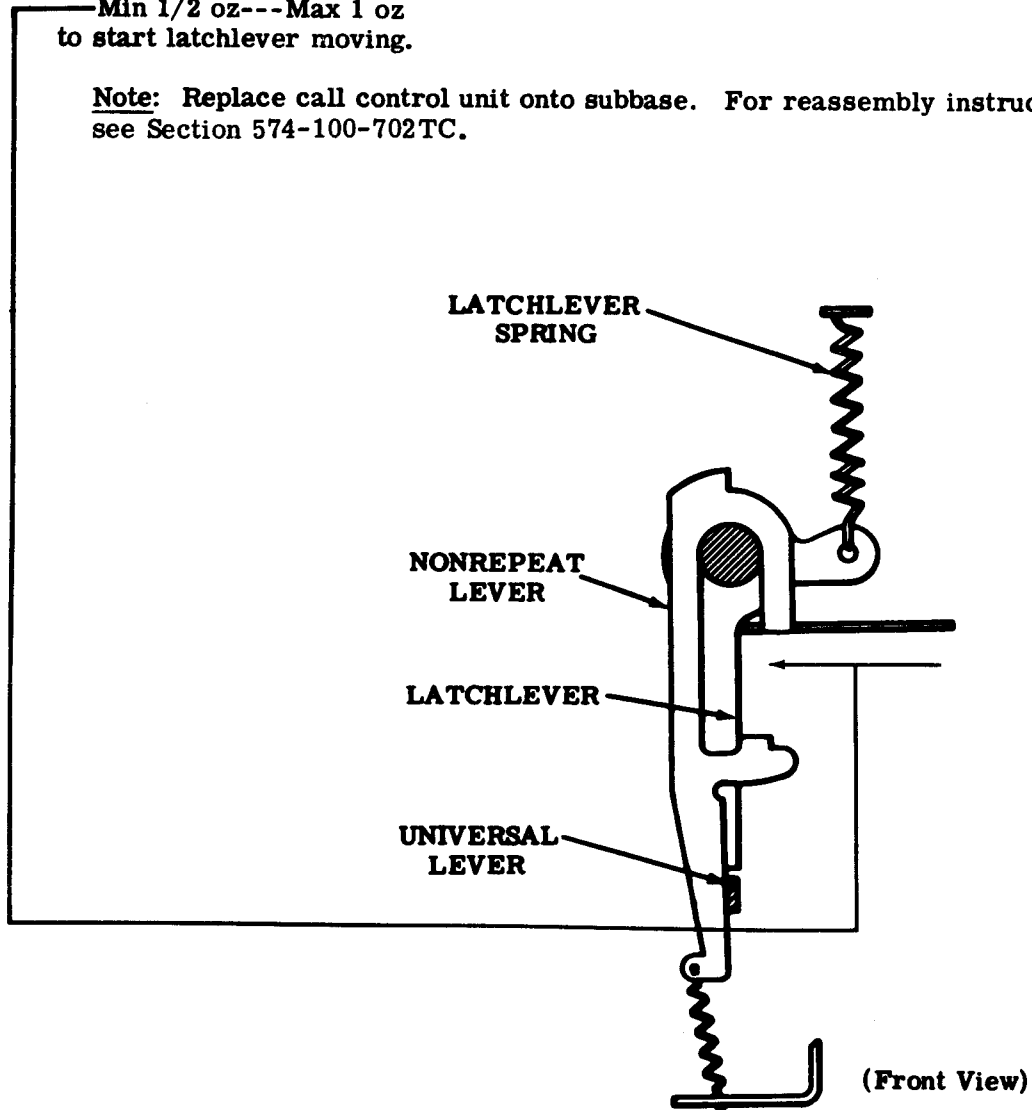

2.16 Distributor Trip Linkage

DISTRIBUTOR TRIP LINKAGE - Method 1
 (Using the TP186308 keyboard adjusting gauge)

→ **Note:** When making or checking this adjustment use either Method 1 or Method 2 (2.17). Do not intermix methods.

To Check

→ Place the typing unit in stop condition. Depress DELETE key to trip distributor clutch. From the front of the keyboard, manually push the universal lever down to its latched position. Place the TP186308 gauge on front of keyboard frame. Rotate distributor shaft until its cam post (LATE DESIGN) or cam roller (EARLY DESIGN) is on the high part of the cam follower lever camming surface.

Requirement

The top edge of the universal lever, which is now in the lowest position, should be within the thickness of the gauge's lower tab as gauged by eye.

To Adjust

Loosen clamp screw friction tight. Using pry points and slot in casting position trip linkage adjusting bracket until requirement is met. Tighten clamp screw.

Related Adjustment

Affects

→ TRIP LEVER ENGAGEMENT (See Section 574-122-700TC)

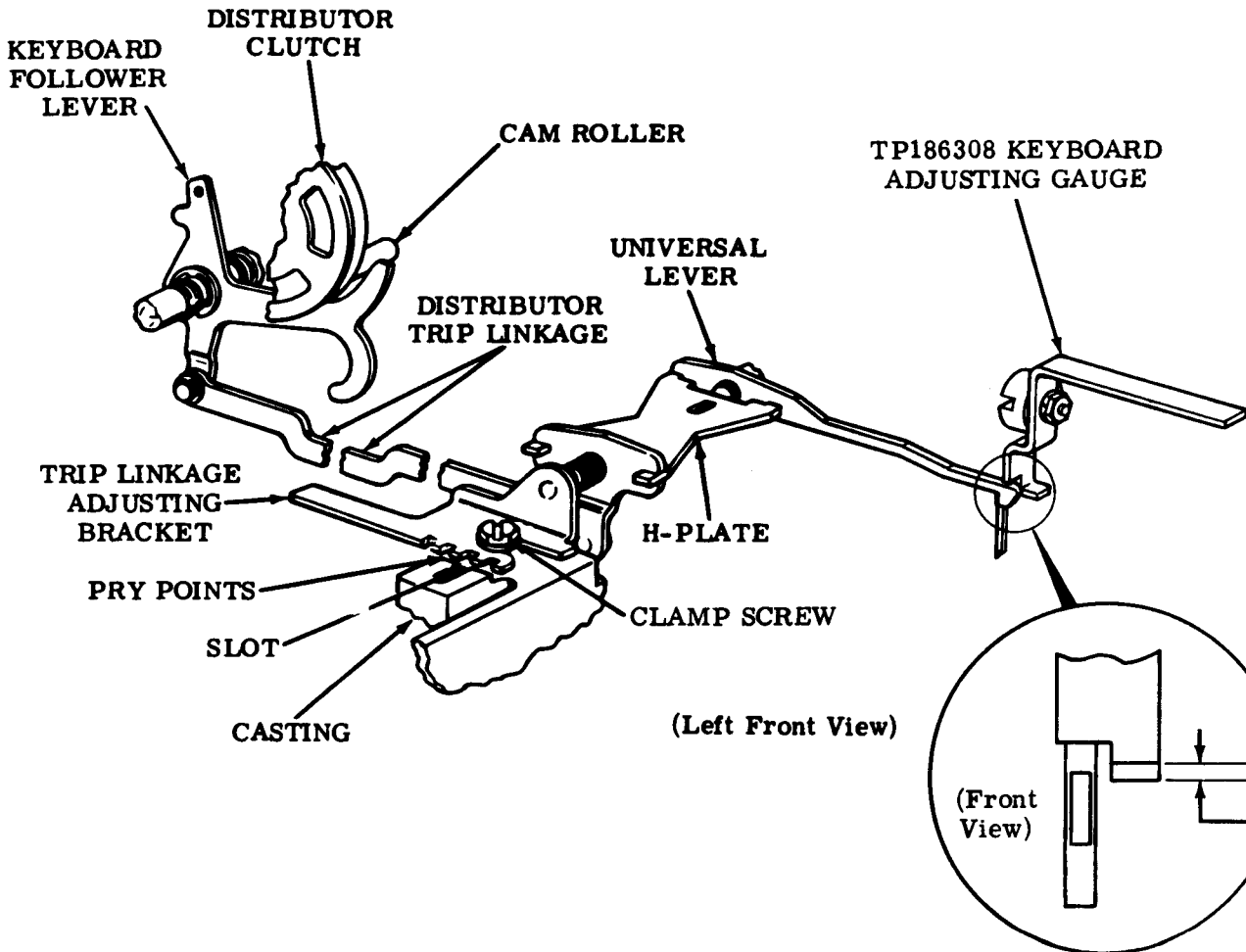

2.17 Distributor Trip Linkage (continued)

Note 1: When making or checking this adjustment use either Method 1 (2.16) or Method 2. Do not intermix methods.

DISTRIBUTOR TRIP LINKAGE - Method 2
(Not using the TP186308 keyboard adjusting gauge)

Note 2: The requirement applies to early and late design keyboards having the TP180086, TP182240, or TP185766 universal lever.

To Check

Place the typing unit in stop condition. Depress the DELETE key to trip the distributor clutch. Rotate the distributor shaft until the keyboard follower lever is on the high part of its cam. Push against reset bail spring anchor with just enough force to slightly move the reset bail, then release.

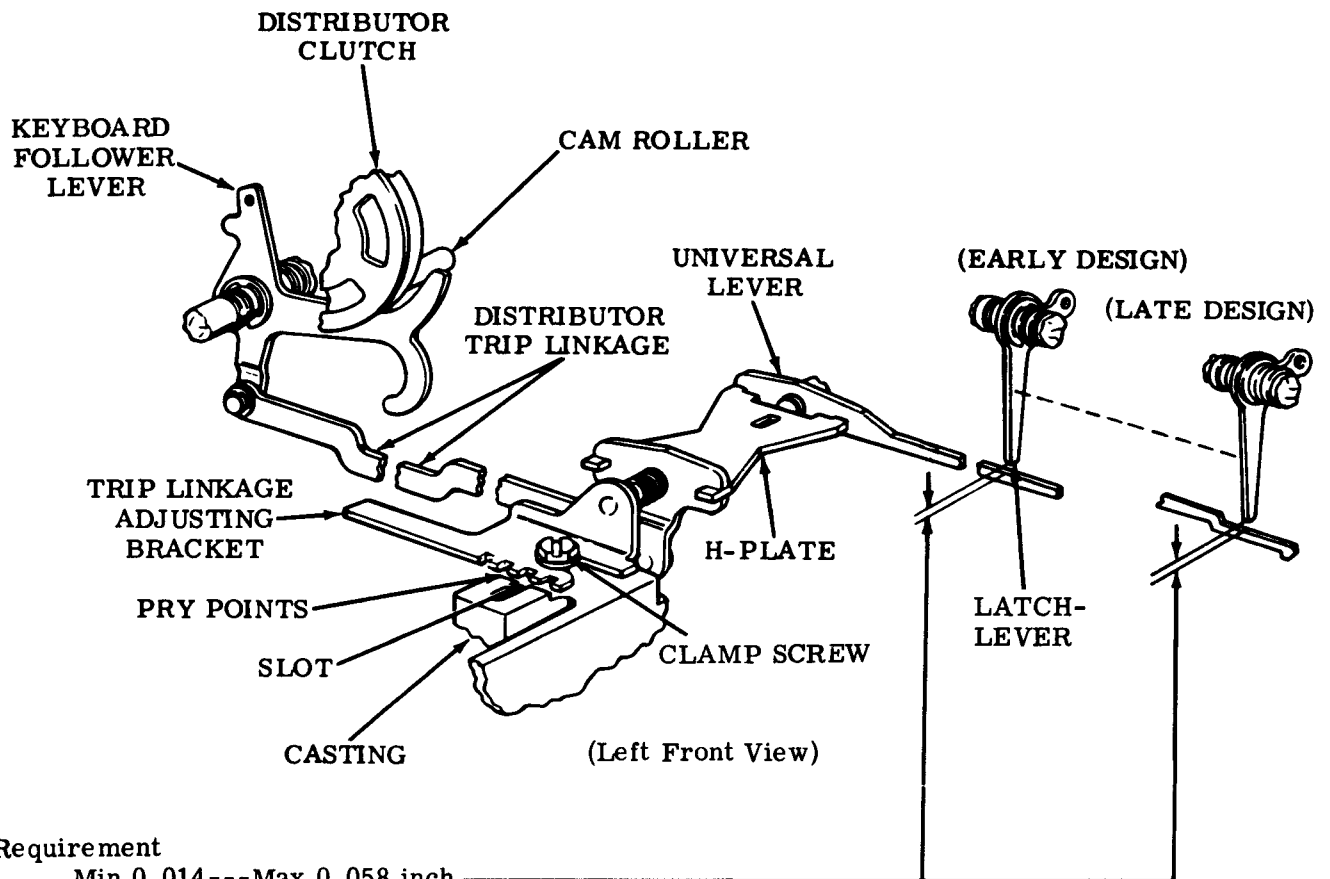
**Requirement**

Min 0.014---Max 0.058 inch
between latchlever and universal lever.

To Adjust

Loosen clamp screw friction tight. Using pry points and slot in casting, position trip linkage adjusting bracket until requirement is met. Tighten clamp screw.

Related Adjustment**Affects**

TRIP LEVER ENGAGEMENT (See Section 574-122-700TC)

33 TYPING UNIT

ADJUSTMENTS

CONTENTS	PAGE	CONTENTS	PAGE
1. GENERAL	4	Keyboard follower lever spring . . .	17
2. BASIC UNIT	9	Shaft left bearing gap	11
Carriage Area		Stop bail spring	17
Final printing alignment	131	Trip lever engagement	14
Fourth pulse linkage positioning	55	Trip shaft position	12
Front rollers clearance	51	Form Feed Area	
Left slide guideplate reset	61	Cam lobe position - S	106
Power bail roller clearance	52	Clutch shoe lever gap - S	102
Print drive lever positioning	56	Form feed belt tension - S	101
Print hammer bail spring	67	Form-out bail spring - S	120
Print hammer trip lever release	62	Form-out contact operating bail	
Print hammer trip lever reset	63	clearance - S	120
Print hammer trip lever spring	67	Form-out contact pressure and	
Print suppression latchlever		gap - S	120
endplay	58	Form-out lever overtravel - S	105
Print suppression latchlever		Form-out lever — reset clearance	
release	65	- S (early design)	108
Rack and pinion backlash	52	Form-out lever — reset clearance	
Rear rail position	53	- S (late design)	109
Rear roller clearance	54	Form-out lever spring - S	105
Reset lever positioning	57	Latchlever assembly spring - S . . .	105
Ribbon drive lever spring	71	Latchlever spring - S	102
Ribbon feed pawl spring	71	Line feed bail spring - S	115
Ribbon guide spring	67	Line feed lever line-up and	
Ribbon positioning	64	endplay - S	104
Ribbon power lever drive	70	Line feed lever spring - S	115
Ribbon ratchet spring	71	Line feed pawl stripping - S	114
Ribbon reverse arm spring	71	Line feed selection	115
Right side guideplate reset	60	Reset follower lever spring - S . . .	106
Rotary drive bail spring	68	Trip lever engagement (final) - S	
Slide guideplate springs	59	(late design)	112
Slide springs	69	Trip lever engagement — form-out	
Typewheel "home" position		- S	110
(preliminary)	66	Trip lever engagement — line feed	
Typewheel positioning (preliminary) .	59	- S (early design)	111
Typewheel return spring	68	Trip lever engagement —	
Vertical drive bail spring	68	(preliminary) - S	103
Distributor Area		Trip lever spring - S	102
Brush holder gap	11	Trip lever upstop position - S	
Brush holder position	15	(early design)	113
Brush holder spring	16	Trip shaft endplay - S	104
Clutch latchlever spring	16	Function Area	
Clutch shoe lever gap	13	Automatic codebar spring	41
		Bearing alignment	33

CONTENTS	PAGE
Bell clapper gap	50
Blocking lever springs	39
Carriage drive bail endplay	50
Carriage return lever — latch clearance	49
Carriage return spring	50
Codebar guide position	40
Codebar reset bail spring	36
Codebar reset guide position	38
Codebar reset lever line-up	35
Codebar reset lever position	36
Codebar springs	41
Coding and installation of TP180801 universal function lever	155
End-of-line bell signal - S	130
End-of-line latch spring	80
Function bail spring	45
Function lever code arrangement	156
Function lever retainer	45
Function lever springs	43
Function pawl spring	42
Function shaft and casting position	48
Left rocker drive	42
Line feed function strip lever spring - S	43
Line length selection	128
Main shaft rotation	33
Margin bell bellcrank clearance	129
Print suppression and no. 4 codebar spring	41
Print suppression cam follower spring	47
Print suppression latch — horizontal clearance	37
Print suppression latch — vertical clearance	47
Right rocker drive	44
Rocker shaft position and endplay	34
Selector blocking levers positioning	39
Stripper bail clearance	46
Main Shaft Area	
Clutch shoe lever spring	25
Clutch shoe spring	25
Codebar and function clutch latchlever springs	24
Codebar and function clutch shoe lever gaps	24
Codebar clutch endplay	20
Codebar clutch trip lever engagement	22
Codebar clutch trip lever line-up	21
Driven gear line-up	20
Form feed clutch endplay - S	100
Function clutch endplay	19
Function clutch position (preliminary)	19

CONTENTS	PAGE
Function clutch trip lever engagement	23
Latchlever endplay	100
Left bearing position	18
Selector cam endplay	18
Trip lever springs	23
Trip shaft latchlever endplay	21
Motor Area	
Belt tension (final)	10
Belt tension (preliminary)	10
Gear backlash	9
Paper Controls	
Paper alarm contact lever clearance - S	126
Paper alarm contact pressure and gap - S	126
Paper lever spring - S	126
Platen Area	
Cam zero position	117, 118
Copyholder wire position - F	93
Detent position - F	85
Detent position - S	116
Detent ratchet pawl spring - S	116
Form length selection - S	119
Idler position - S	107
Left margin position - F	80
Left margin position - S	125
Line feed blocking lever spring - F	86
Line feed drive arm clearance - F	87
Line feed drive link position - F	89
Line feed drive link spring — horizontal - F	86
Line feed drive link spring — vertical - F	86
Line feed pawl downstop position - F	90
Line feed pawl spring - F	85
Line feed selection - F	84
Line feed stripper plate clearance - F	92
Line feed upstop bracket position - F	88
Paper guide springs - F	81
Paper guide spring - S	94
Paper guideplate clearance - S	99
Paper guideplate springs - F	81
Paper guideplate spring - S	94
Paper straightener bail spring - F	81
Platen detent pawl spring - F	89
Platen endplay - F	95
Platen — horizontal position - F	78
Platen — horizontal position - S	96, 97
Platen knob position - S	94
Platen knob spring - S	94

CONTENTS	PAGE	CONTENTS	PAGE
Pressure roller clearance - F	91	Armature spring	143
Printing line position (final) - S	122	Blocking follower lever spring	133
Printing line position (preliminary)		Blocking latch spring	143
- S	121	Blocking link clearance	132
Reset follower lever — reset		Character suppression contact	
position - S	117	wire gap	142
Right margin position - S	125	Code contact wire gap	146
Right paper guide position - S	123	Coding the answer-back drum	158
Vertical type alignment - F	79	Contact wire spring	145
Vertical type alignment - S	97, 98	Control lever spring — horizontal	133
Wire guide position - S	124	Control lever spring — vertical	
Zeroizing button - S	107	(early design)	143
Selector Area		Control lever spring — vertical	
Armature bracket position		(late design)	144
(preliminary)	26	Detent spring	145
Armature spring	28	Drum position	134
Latchlever spring	29	Feed lever position	136
Pushlever springs	31	Feed lever spring	146
Receiving margins	130	Feed pawl position	137
Selector clutch torque	32	Feed pawl spring	145
Selector lever springs	30	HERE IS bellcrank positioning	138
Shoe lever gap and trip lever		Tripbail positioning	139
engagement	27	Trip lever adjusting tab clearance	141
Spacing locklever spring	30	Trip lever clearance	135
Start lever spring	29	Trip lever overtravel and armature	
Stripper bail spring	31	gap	140
Trip lever spring	27	Trip lever spring	144
Spacing Area		Trip magnet position	141
Carriage bounce	83	Auxiliary Contact Assembly (TP183549)	
Carriage return arm springs	83	Front contact spring	149
Carriage return latch spring	83	Time delay contact bracket position	149
Carriage return lever spring	74	Function Area	
Carriage return lever — unlatch		Coding and installation of TP180801	
clearance	82	universal function lever	155
Check pawl spring	76	Function Box Switches	
Feed pawl spring	75	Contact assembly position	147
Feed pawl stop position	72	Print-Nonprint	
Feed pawl travel	76	Armature spring	151
Left margin printing	127	Latch bellcrank spring	152
Space bellcrank spring	72	Nonprint codebar spring	154
Space suppression lever clearance —		Nonprint function lever clearance	150
printing	73	Release magnet overtravel	152
Space suppression lever clearance —		Solenoid bracket position	151, 153
spacing	74	Receive-Only Sets	
Space suppression lever spring	75	Keyboard adjusting bracket	
Spacing belt tension	77	position	148
3. VARIATIONS TO BASIC			
ADJUSTMENTS	132		
Answer-Back Area			
Answer-back drum code			
arrangement	161		

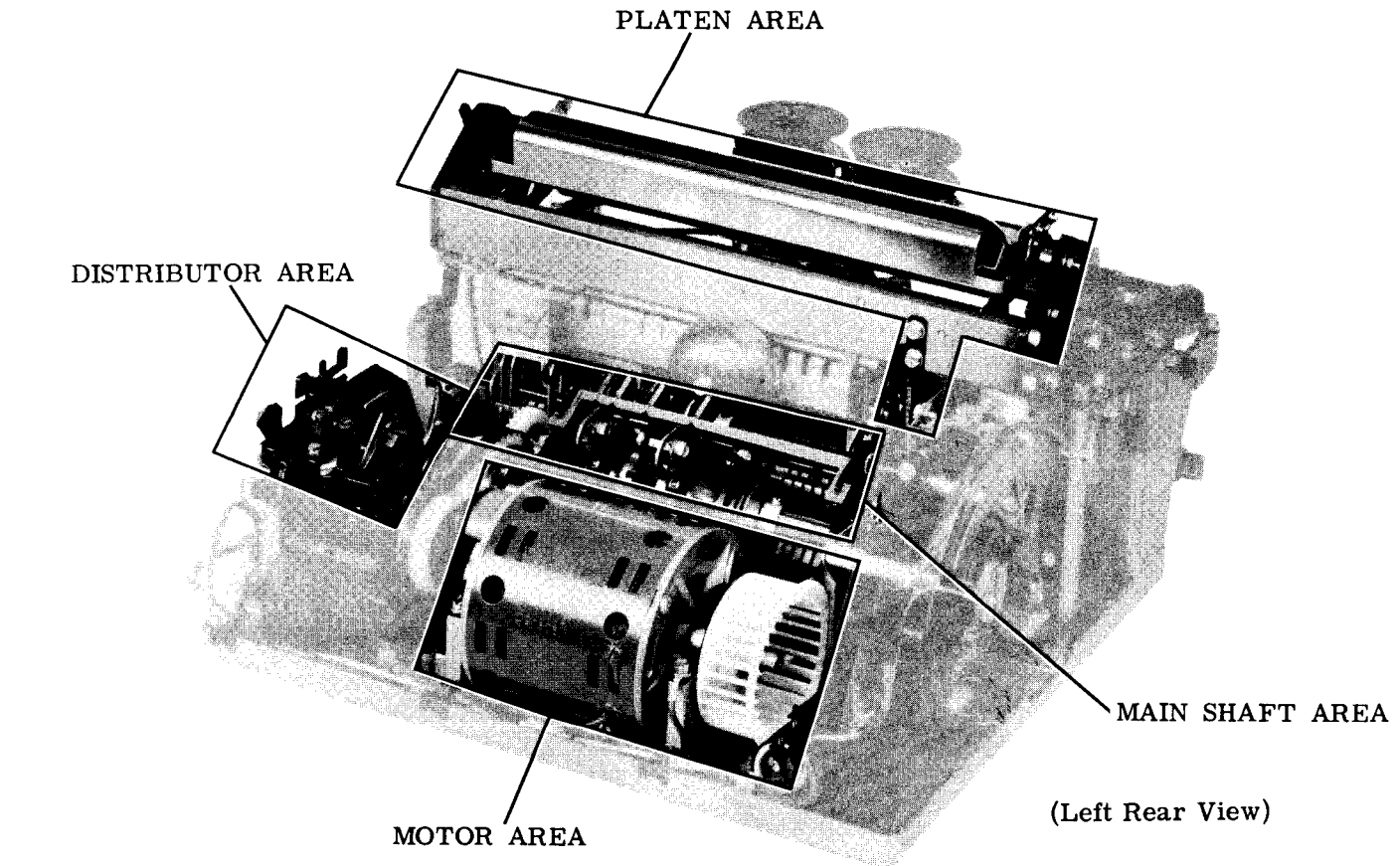

Figure 1 - Distributor, Main Shaft, Motor, and Platen Areas

1. GENERAL

1.01 This section provides adjustment information for the 33 typing unit. It is re-issued to include the latest changes. Marginal arrows indicate the changes.

1.02 In the adjustments covered in this section, location of clearances, position of parts, and point and angle of scale applications are illustrated by line drawings. Requirements and procedures are set forth in the several texts that accompany the line drawings. Required tools are included in TP185830 maintenance tool kit and are listed in Section 570-005-800TC. A DXD800 Signal Distortion Test Set was used to determine the requirements for the selector receiving margins.

1.03 Adjustments are divided into two categories — basic and variations. Basic adjustments apply to all friction feed and/or sprocket feed typing units. Adjustments found under variations apply only to typing units which

have the particular feature(s) under consideration. The F and S following an adjustment title mean that the adjustment applies only to friction feed (F) or sprocket feed (S) typing units. No letter designation indicates that the adjustment applies to both types of equipment.

1.04 Adjustments are presented in a definite order when which is considered the best to follow when completely readjusting the equipment. Certain interrelated adjustments, which appear on the same page, should be checked and adjusted in a definite sequence. The sequence is indicated by the letters (A), (B), etc. No single adjustment should be undertaken without first completely understanding the procedure and knowing the requirements. Therefore, read a procedure all the way through before making an adjustment or checking a spring tension.

Note: Disconnect the typing unit from any ac or dc potential prior to inspection, minor repair, extensive maintenance, or a complete readjustment.

1.05 References to left, right, front, rear, etc consider the typing unit to be viewed from a position where the carriage area faces

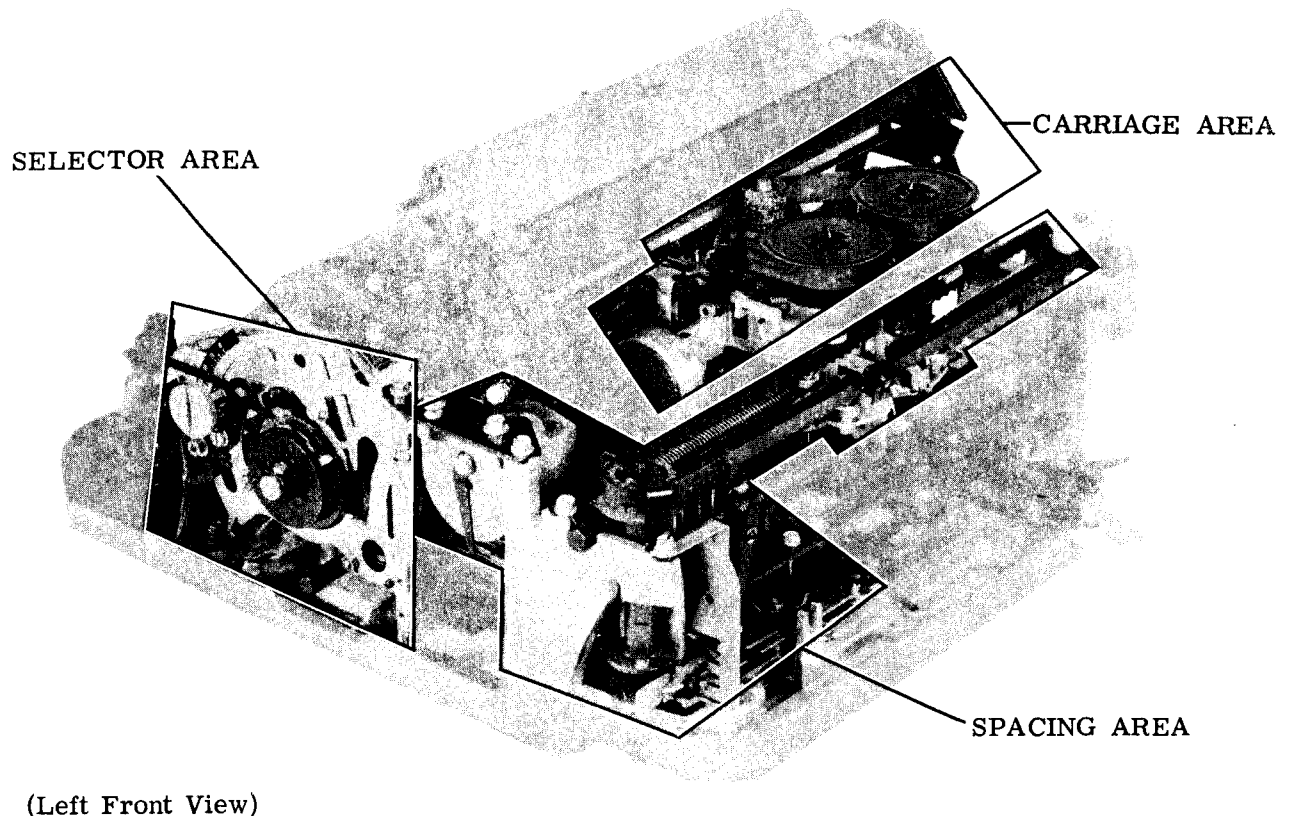

Figure 2 - Carriage, Selector, and Spacing Areas

up and the selector area is located to the viewer's left.

1.06 Unless specifically stated otherwise, make screws or nuts friction tight to make an adjustment and tighten them securely once the adjustment has been made.

1.07 When a procedure calls for using pry points or slots to make an adjustment, place a screwdriver between the points or in the slots and pry parts in the proper direction.

1.08 Due to a high degree of congestion within certain areas of some typing units, some disassembly will be required prior to making certain adjustments. If parts or subassemblies are removed from the typing unit to facilitate the making of an adjustment, be sure that they are subsequently replaced. Recheck any adjustments that may have been affected by the removal of parts or subassemblies.

Note 1: Do not remove parts and/or subassemblies unless it is considered absolutely necessary to perform an adjustment.

Note 2: Instructions for the disassembly and reassembly of parts and/or subassemblies are given in the appropriate disassembly and reassembly section and/or appropriate illustrated parts section.

Note 3: Do not lift typing unit while holding any part of the selector mechanism. Excessive strain on the selector mechanism, due to the weight of the typing unit, may cause selector malfunctioning. See appropriate disassembly and reassembly section for the proper method of lifting typing unit from its subbase.

1.09 Related adjustments are listed with some of the adjustment texts and are primarily intended to aid in troubleshooting the equipment. As an example, suppose that in searching for a

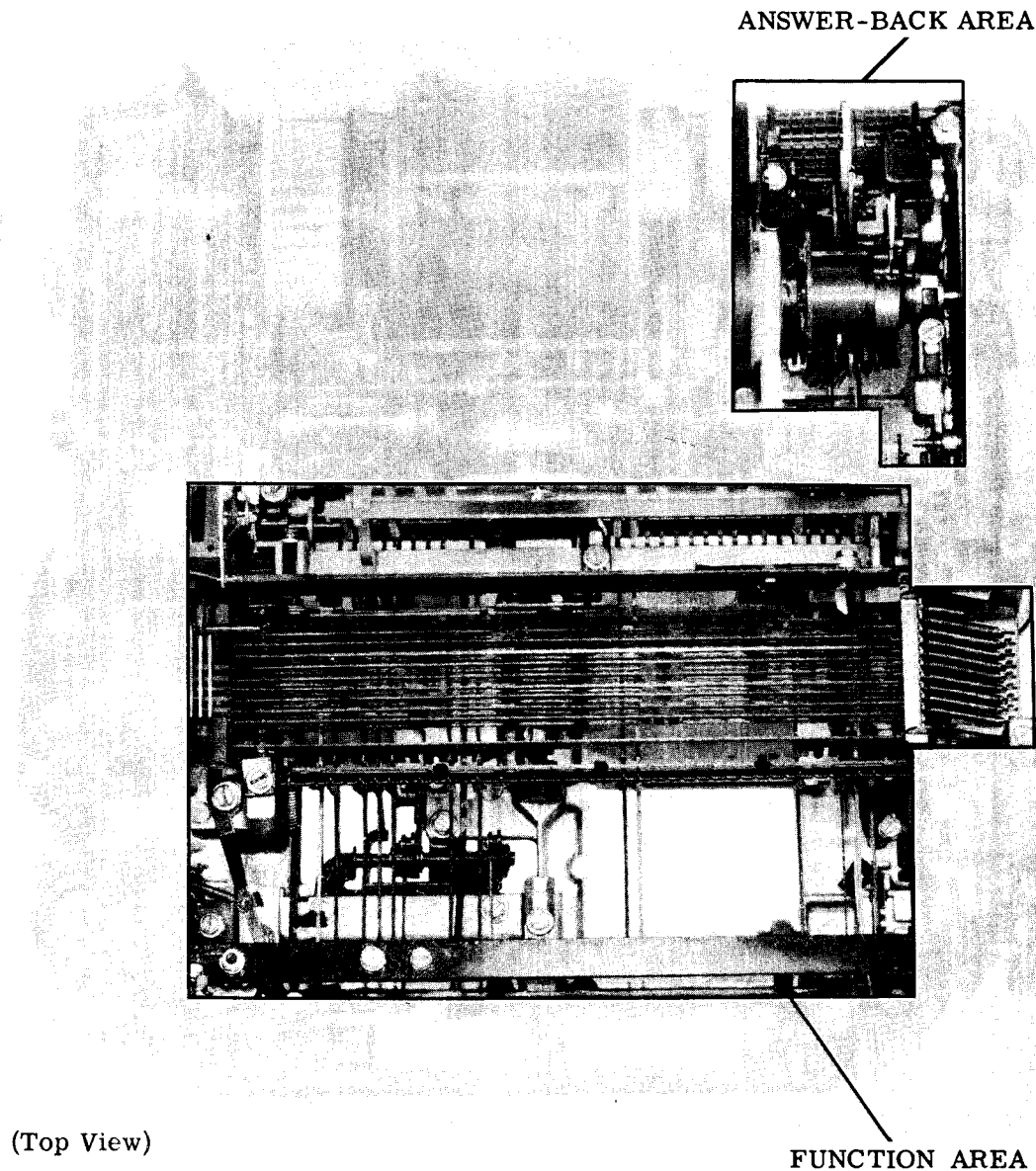

Figure 3 - Answer-Back and Function Areas

trouble it is discovered that the FUNCTION CLUTCH POSITION adjustment does not meet its requirement. Under Related Adjustments it is indicated that this adjustment is affected by the LEFT BEARING POSITION adjustment. First, check it to see if it is the cause of the trouble. Also, it is indicated that the FUNCTION CLUTCH POSITION adjustment affects FUNCTION CLUTCH ENDPLAY, CODEBAR CLUTCH ENDPLAY, and CODEBAR CLUTCH TRIP LEVER LINE-UP adjustments. If the former adjustment is changed, check the latter adjustments.

Note: Information in parentheses () following any related adjustment gives the associated paragraph number and area, if different from the paragraph number at the top of the page.

1.10 The spring tensions specified in this section are indications, not exact values. Therefore, to obtain reliable readings, it is important that spring tensions be measured by spring scales placed in the positions shown on pertinent line drawings. Springs that do not meet their requirements should be replaced by

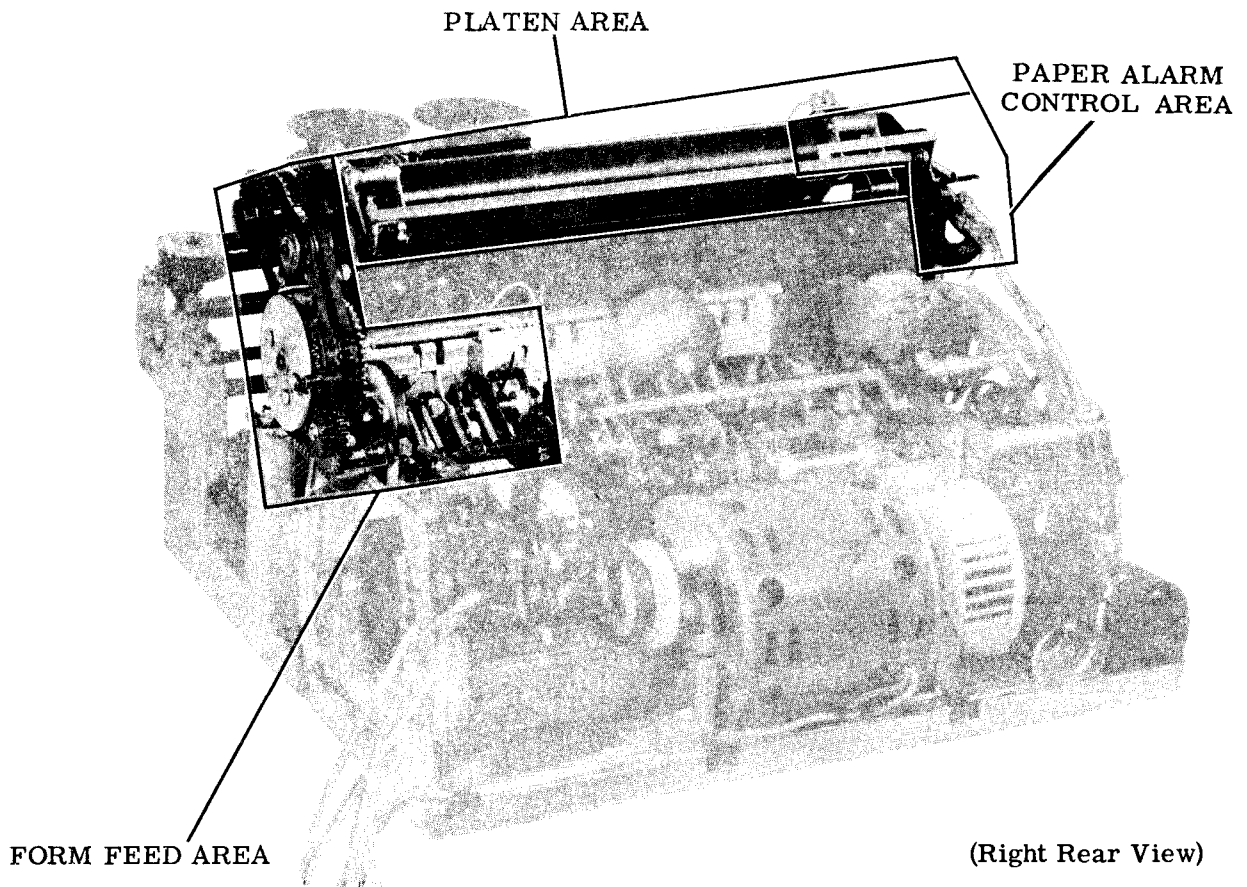

Figure 4 - Paper Alarm Control, Form Feed, and Platen Areas

new ones. Only those springs that directly affect the operation of the typing unit are measured, however, others may be measured indirectly in the process. If, at first, the spring tension requirement cannot be met, replace the indicated spring being directly measured. Then if the requirement is not met, any springs that are indirectly measured in the procedure should be replaced, one at a time, with the performance of requirement checks each time a spring is replaced.

Note 1: Use only spring scales which are recommended by the manufacturer and found in Maintenance Tools Section 570-005-800.

Note 2: The spring tensions may be checked in any sequence.

1.11 All adjustment procedures should be started with the typing unit in the stop condition. It is in the stop condition when the selector armature is in its attracted (frontward) position and all clutches are disengaged.

1.12 To place the typing unit in the stop condition, use TP185832 armature clip to hold the selector armature in its attracted

(frontward) position. Rotate the main shaft clockwise (as viewed from the left) until all clutches are in a stop position. Fully disengage all of the clutches as instructed in 1.13 following.

Note 1: A stop position is that position where a shoe lever contacts a trip lever.

Note 2: The distributor clutch will not disengage if the typing unit is removed from a set unless the keyboard adjusting bracket is adjusted per 3.17. Adjustment must be remade to set requirements when the typing unit is replaced in an ASR or KSR set.

Note 3: The distributor clutch will not disengage unless the answer-back drum is in its home position, which is the position where the control lever is fully detented into the indent on the answer-back drum.

1.13 When disengaged, a clutch is latched so that a shoe lever is held in its stop position by a trip lever while a corresponding

latchlever is seated in a notch of the clutch disc. This allows the clutch shoes to release their tension on the clutch drum. With all clutches disengaged, the main shaft will turn freely without any clutch shoes dragging.

Note: If the shaft is turned by hand, a clutch will not fully disengage upon reaching a stop position. Where an adjustment procedure calls for disengagement, rotate the clutch to a stop position, apply a screwdriver to the associated stop-lug, and push the clutch disc in the normal direction of main shaft rotation until the corresponding latchlever seats in its clutch disc notch. As a reminder, the word "latched" follows instructions to disengage the clutches.

1.14 A clutch is engaged when a trip lever is moved up so that it no longer holds a shoe lever in its stop position. When this action occurs, the shoe lever and a stop-lug on the clutch disc move apart, and the clutch shoes wedge against the drum, so that when the shaft is turned, the clutch will turn in unison with it.

1.15 Manual Operation: To manually operate the typing unit, place it in the stop condition as instructed in 1.12 and 1.13. Momentarily permit the armature to move to its unattracted (rearward) position to trip the selector clutch. Slowly rotate the main shaft clockwise (as viewed from the left) until all push levers have moved under their respective selector levers. Using a spring hook, strip the push levers from under the selector levers corresponding to the spacing elements of the code combination to be set up. Then continue to rotate the main shaft until the proper condition is set up or the character is cleared through the typing unit.

1.16 The selector levers are numbered 1, 2, 3, 4, 5, 7, 6, and 8 from left to right. To set up the character Y, for example, whose 8-level code combination is 1--45-78, strip the push levers from the 2, 3, and 6 selector levers.

1.17 Code combinations within this section are not always given as parity codes. Parity codes are obtained by proper transfor-

mation of the eighth code level as explained in the typing unit principles of operation section.

1.18 To aid in physically locating the adjustments and spring tensions, the typing unit is divided into eleven areas. These areas are indicated in Figures 1 through 4 as follows:

<u>Area</u>	<u>Figure</u>
Carriage	2
Distributor	1
Function	3
Main Shaft	1
Motor	1
Selector	2
Spacing	2
Platen	1, 4
Form Feed	4
Answer-Back	3
Paper Alarm Control	4

1.19 To facilitate making the adjustments remove the typing unit from the subbase. For instruction, see the appropriate disassembly and reassembly section.

1.20 Carriage Drive Bail and Function Bail Positioning: The following procedures may be used to locate the carriage drive bail and the function bail positions on units having indicator marks on the function cam and carriage drive link:

(a) The carriage drive bail is in its most rearward position when the indicator mark on the carriage drive link is centrally located within the second notch on the function cam and the hole in the cam is toward the rear.

(b) The function bail is in its uppermost position when the mark on the carriage drive link is centrally located within the first notch on the function cam and the hole in the cam is down.

(c) The function bail is in its lowermost position when the mark on the carriage drive link is centrally located within the third notch on the function cam and the hole in the cam is up.

2. BASIC UNIT

2.01 Motor Area

GEAR BACKLASH**To Check**

Find position of tightest pinion and intermediate gear engagement. Hold intermediate gear stationary. Observe fan rim radial motion.

Requirement

Min 0.010 inch---Max 0.032 inch
play at fan rim.

To Adjust

Loosen mounting screws and position motor gear bracket. Tighten screws.

Related Adjustment**Affects**

BELT TENSION (2.02)

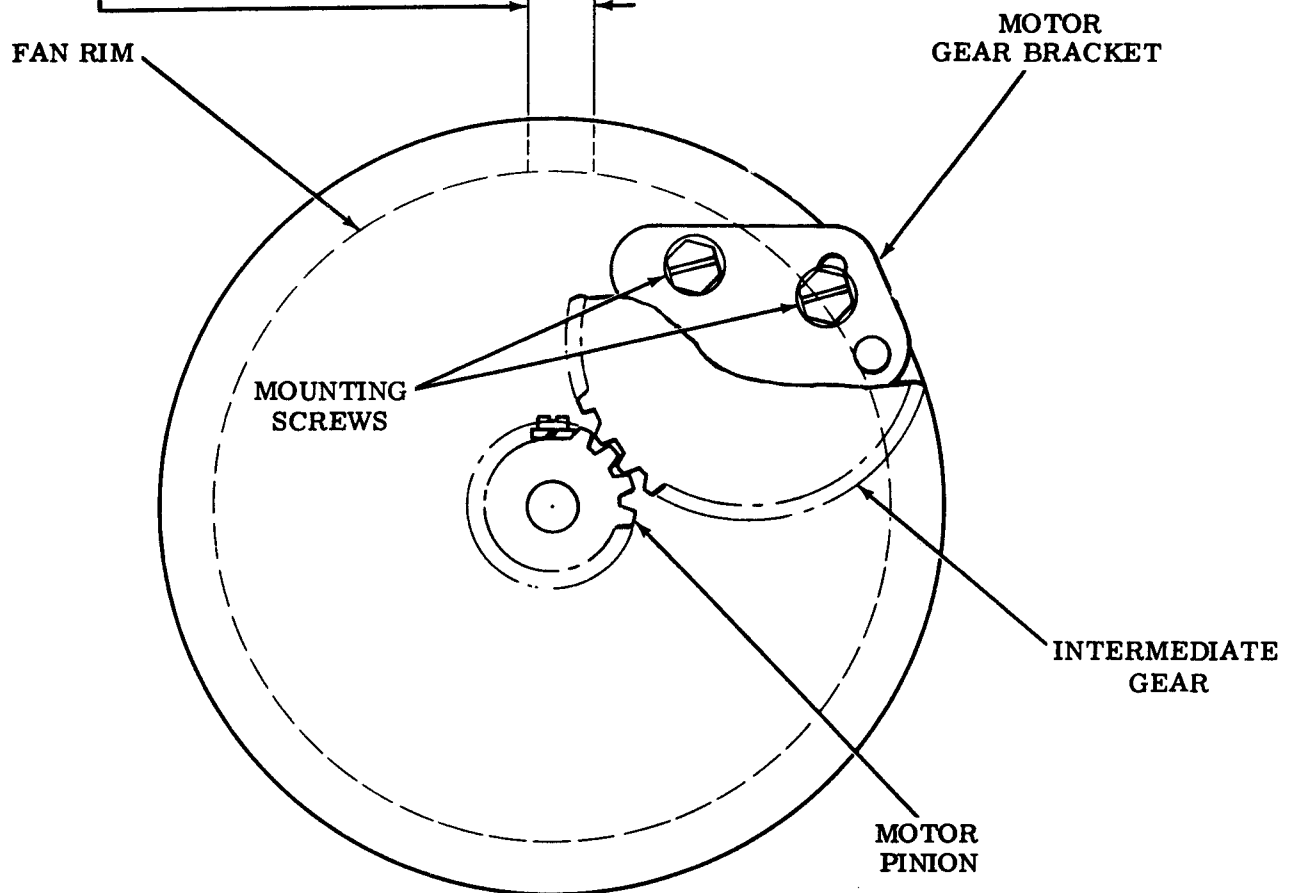

(Right Side View)

2.02 Motor Area (continued)

BELT TENSION (Preliminary)

To Check

Rotate fan clockwise (viewed from left) until upper level of motor belt becomes taut. Using a spring scale, apply 16 oz force at center of belt.

Requirement

Min 0.100 inch---Max 0.135 inch deflection at center of motor belt.

To Adjust

Loosen four clampscrews and rotate motor in cradle. Tighten clampscrews.

Related Adjustments

Affected By

GEAR BACKLASH (2.01)

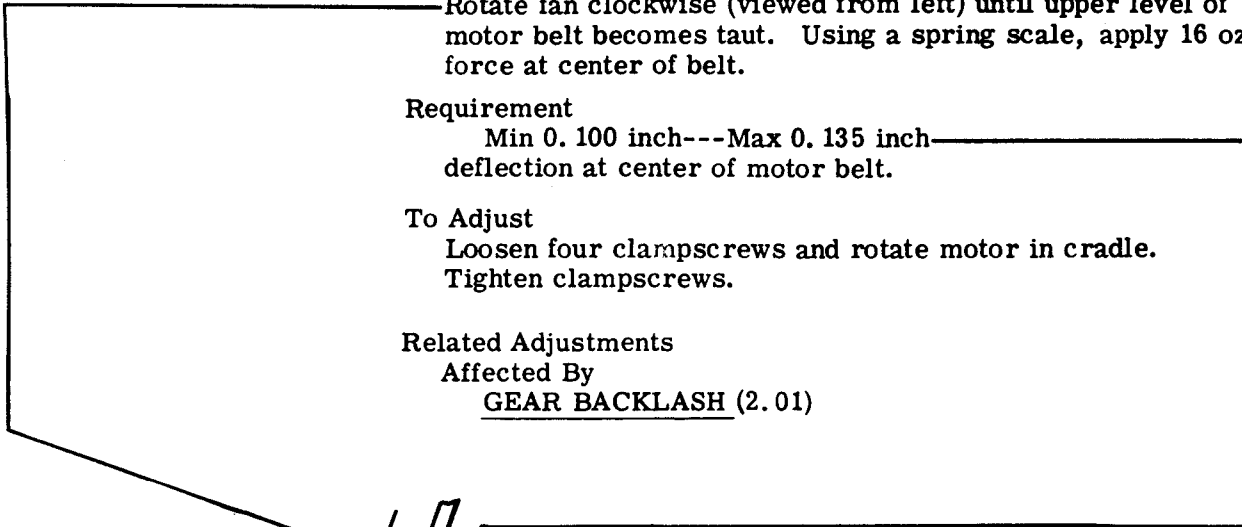

BELT TENSION (Final)

Preliminary requirements should be considered final if RECEIVING MARGIN requirements (2.124) can be obtained. If RECEIVING MARGIN requirements cannot be obtained, refine BELT TENSION (Preliminary) requirement.

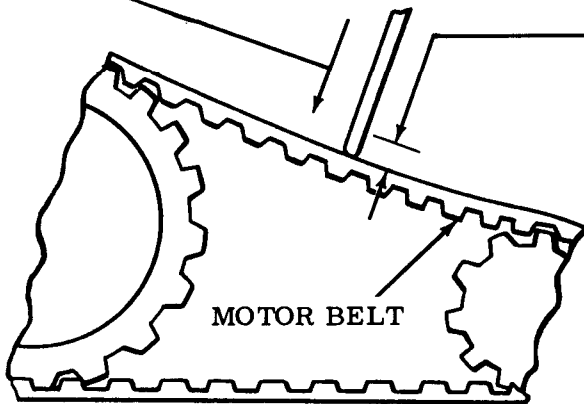

(Right Side View)

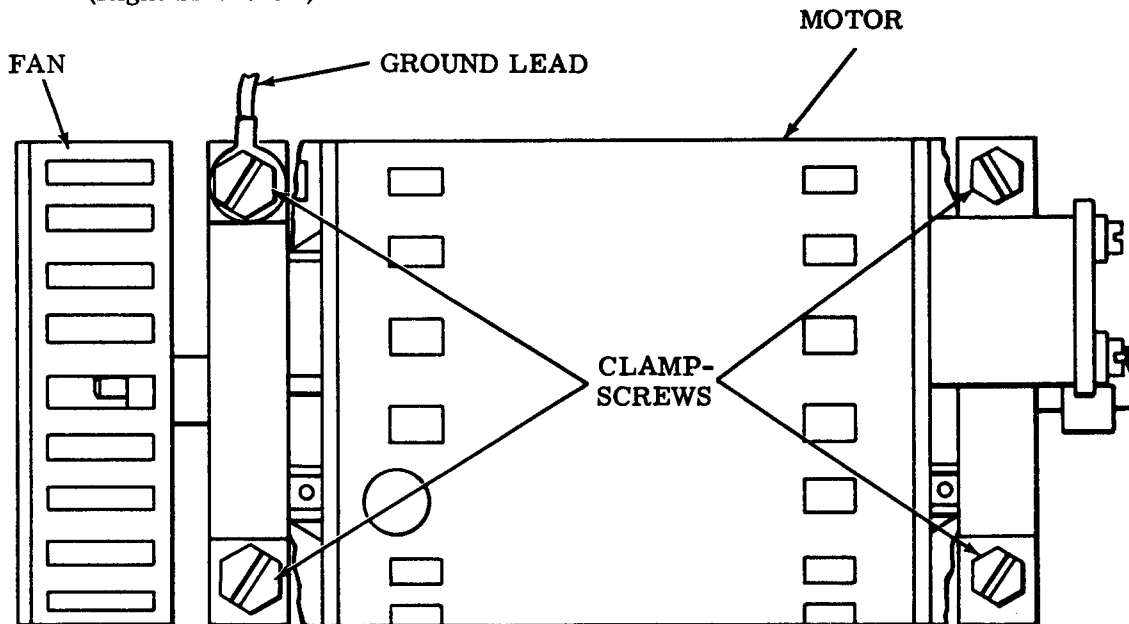

(Top View)

2.03 Distributor Area

(B) SHAFT LEFT BEARING GAP

Requirement

Min some---Max 0.012 inch between left bearing and clutch gear assembly as gauged by eye.

To Adjust

Disengage (latch) distributor clutch. Hold clutch gear assembly firmly to right. Position left bearing with clampscrews loosened. Tighten left bearing clampscrews.

Related Adjustments

Affected By
BRUSH HOLDER GAP (2.03)

(A) BRUSH HOLDER GAP

(1) Requirement

With distributor clutch disengaged (latched)
Min 0.010 inch---Max 0.060 inch between brush holder pointer and disc.

(2) Requirement

During entire brush holder rotation
Min 0.002 inch between any brush holder and disc.

To Adjust

With three bearing clampscrews loosened, position distributor shaft. Tighten right, but not left, bearing clampscrew.

Related Adjustments

Affects
SHAFT LEFT BEARING GAP (2.03)
TRIP SHAFT POSITION (2.04)
DRIVEN GEAR LINE-UP (2.12)

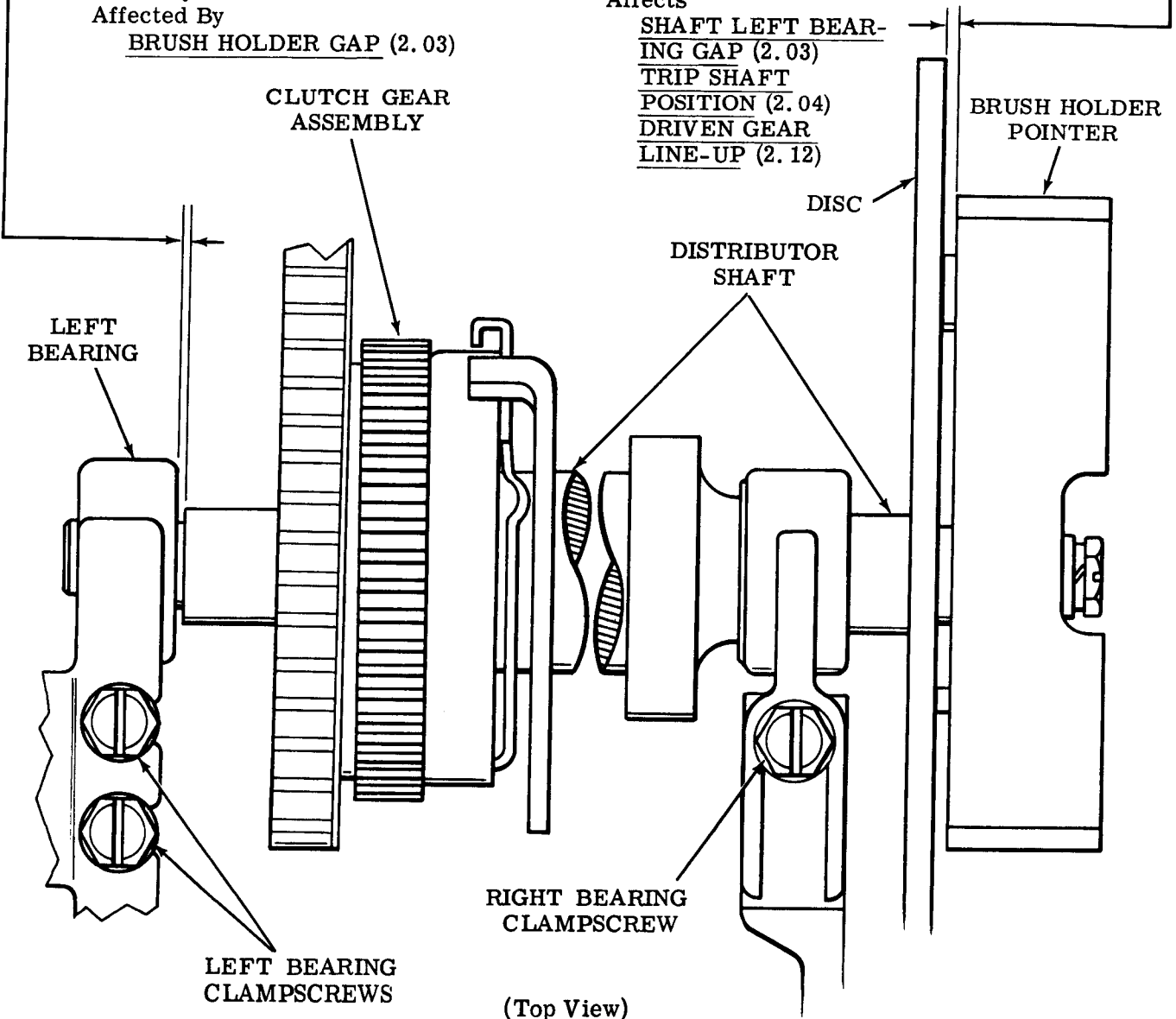

2.04 Distributor Area (continued)

TRIP SHAFT POSITION

To Check

Place distributor clutch in the stop position.

(1) Requirement

With play taken up to minimize all clearances, the trip lever should engage — Min two-thirds width of formed end of shoe lever.

(2) Requirement

Rear extension of control lever should not bind in its slot in answer-back block.

To Adjust

Loosen clampscrew and post friction tight. Move trip shaft right or left to meet requirements and bias trip shaft towards the front. Tighten clampscrew and post.

Related Adjustments

Affects

FEED PAWL POSITION (3.06)

Affected By

BRUSH HOLDER GAP (2.03)

CONTROL LEVER

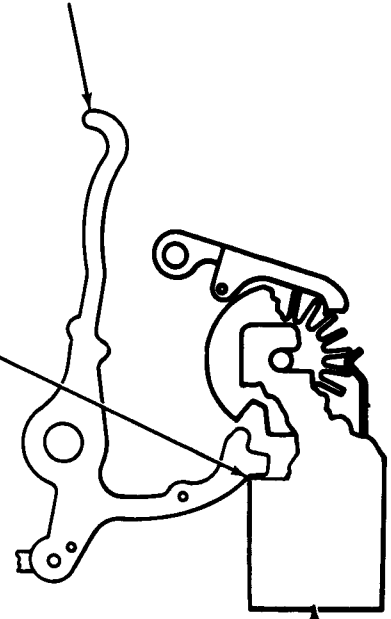

(Right Side View)

ANSWER-BACK BLOCK

POST

CLAMPSCREW

TRIP LEVER

SHOE LEVER

LATCHLEVER

DISTRIBUTOR CLUTCH

TRIP SHAFT

CLUTCH DISC

STOP BAIL

(Top View)

2.05 Distributor Area (continued)

CLUTCH SHOE LEVER GAP

To Check

With distributor clutch disengaged and latched, measure and record clearance between shoe lever and stop-lug. Trip distributor clutch by moving trip lever rearward. Fully seat the clutch shoes by applying slight pressure against the shoe lever along its normal path of forward travel. Measure and record same clearance as above.

(1) Requirement

With distributor clutch disengaged (latched)
Min 0.015 inch
between stop-lug and shoe lever.

(2) Requirement

Clearance between stop-lug and shoe lever
Min 0.050 inch---Max 0.080 inch
greater when distributor clutch is engaged than when disengaged.

To Adjust

Remove answer-back drum. With clamp-screw friction tight, position trip lever using pry point. Tighten clampscrew. Replace answer-back drum.

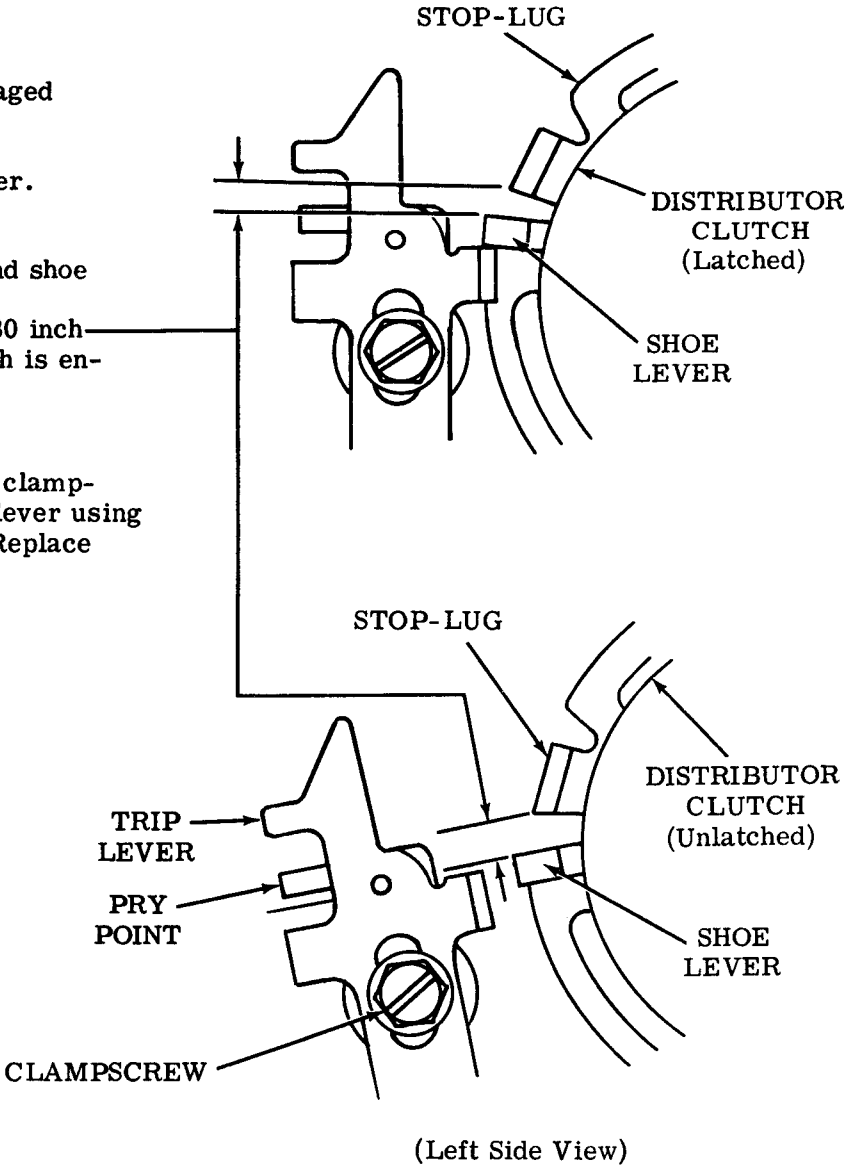

2.06 Distributor Area (continued)

Note 1: Before proceeding, replace typing unit onto subbase. For instructions, see the appropriate disassembly and reassembly section.

Note 2: Do not lift typing unit while holding any part of the selector mechanism. Note the proper method for lifting the typing unit. This method is described in the appropriate disassembly and reassembly section.

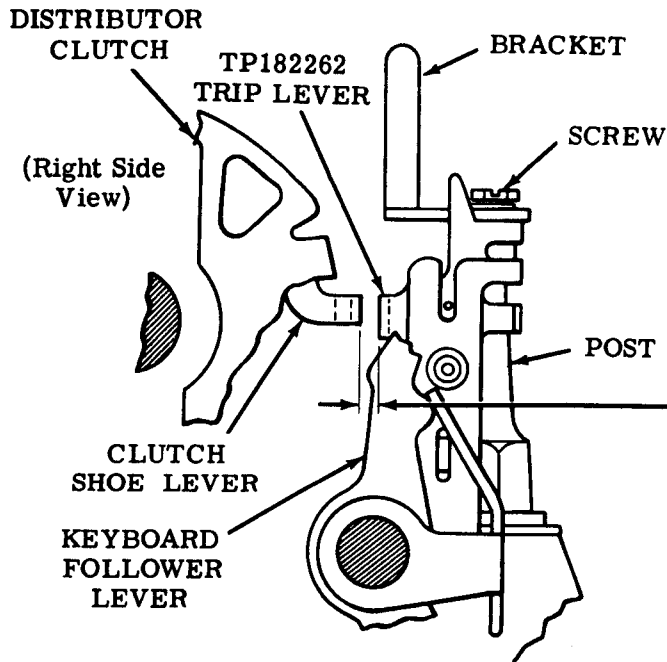

TRIP LEVER ENGAGEMENT

Note 3: The answer-back control lever and reader trip lever should not be touching their respective stop bail adjusting tabs when checking this adjustment.

Note 4: Perform (1) To Check only on late design units containing the TP182262 trip lever.

- (1) To Check
Disengage (latch) distributor clutch. Depress any nonfunction keytop to unlatch distributor clutch. If necessary, loosen screw and position bracket to obtain clearance between bracket and trip lever. Tighten screw. Rotate clutch to align upper edges of shoe lever and trip lever.

Requirement
Min 0.015 inch---Max 0.035 inch between shoe lever and trip lever.

To Adjust
Remove answer-back drum. Use TP180993 bending tool to bend center adjusting tab. Replace answer-back drum.

CAUTION: TO PREVENT ELECTRICAL SHOCK EXERCISE CARE WHEN WORKING WITH TYPING UNIT UNDER POWER.

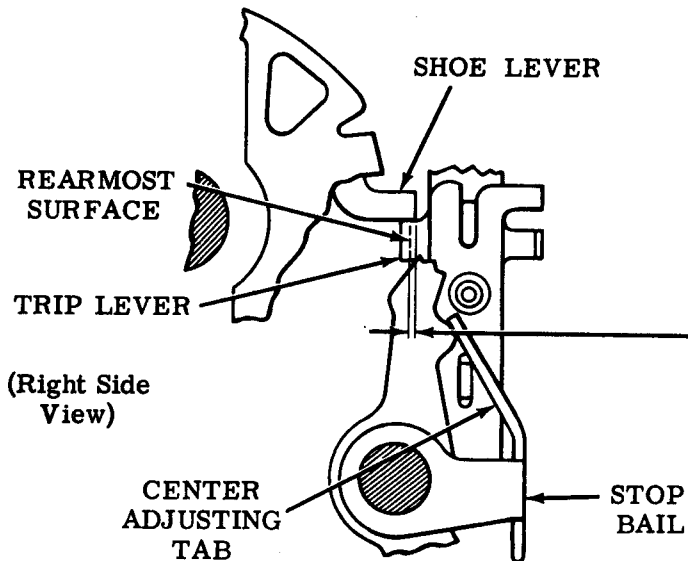

- (2) To Check
Operate typing unit under power. Place keyboard universal lever in latched position.

Requirement
Shoe lever should be
Min flush---Max 0.015 inch beyond rearmost surface of trip lever.

To Adjust
Early Design (without TP182262)
Remove answer-back drum. Use TP180993 bending tool to bend center adjusting tab. Replace answer-back drum.

Late Design (with TP182262)
Loosen screw friction tight and position bracket. Tighten screw.

2.07 Distributor Area (continued)

BRUSH HOLDER POSITION**Requirement**

With distributor clutch disengaged (latched) pointer should be within locating mark.

To Adjust

Loosen mounting screw and position distributor brush holder. Tighten mounting screw.

Note: Rotate the brush holder in a clockwise direction only.

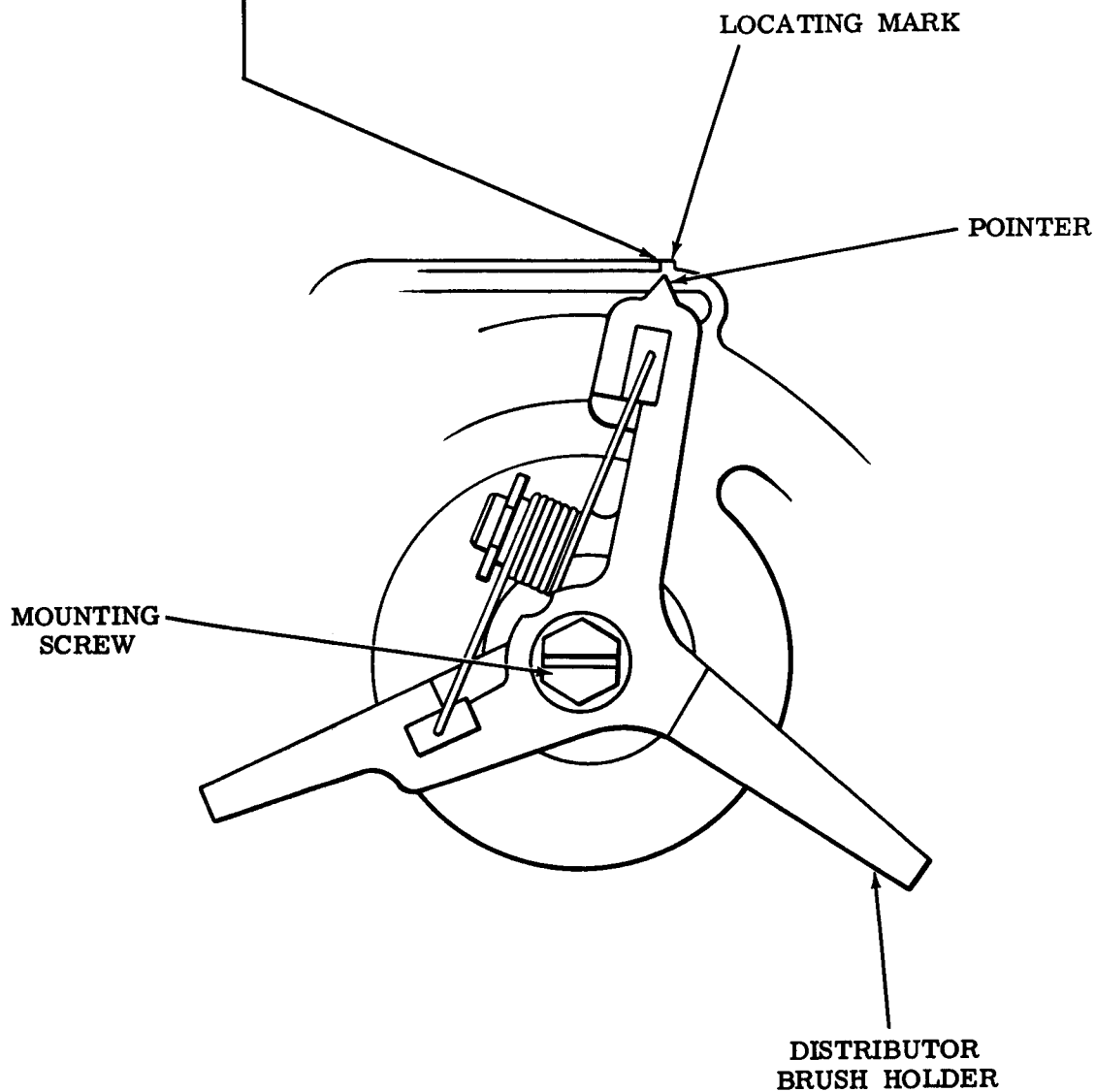

(Right Side View)

2.08 Distributor Area (continued)

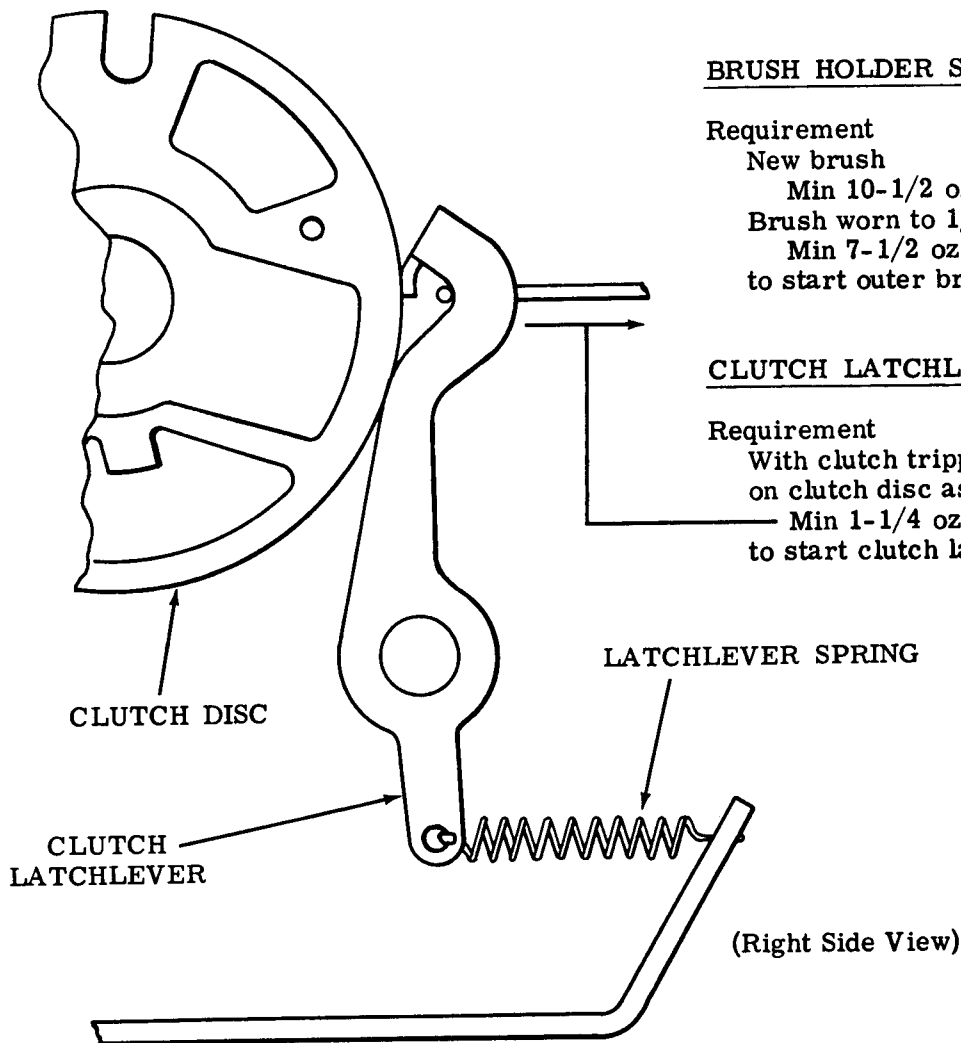
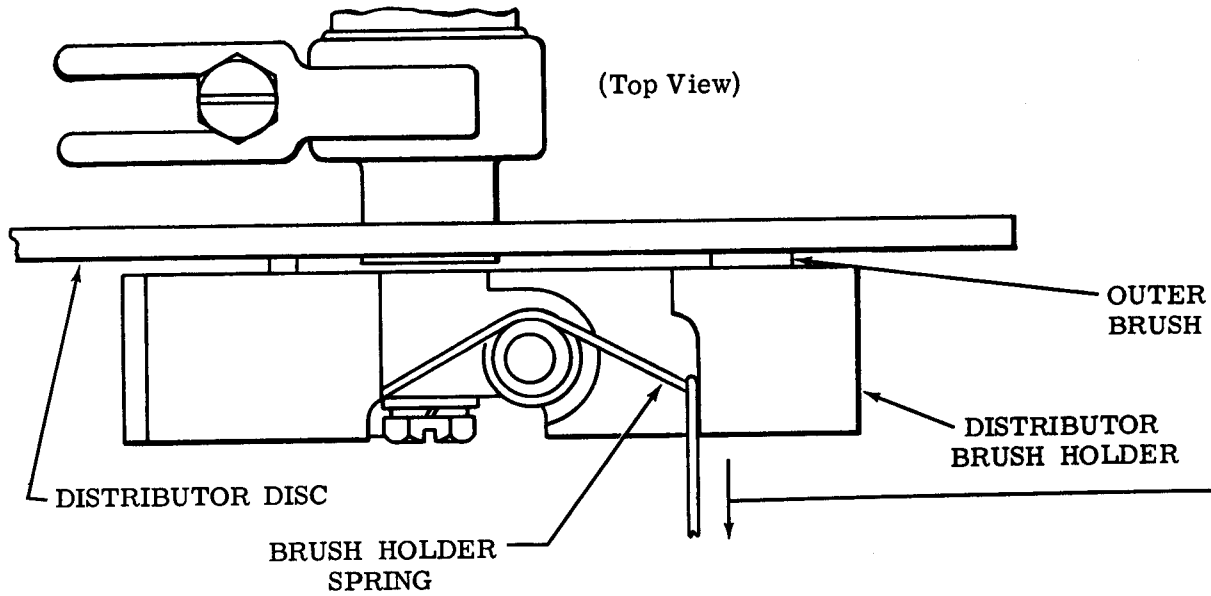

BRUSH HOLDER SPRING

Requirement

New brush

Min 10-1/2 oz---Max 13-1/2 oz

Brush worn to 1/4 inch length

Min 7-1/2 oz---Max 10-1/2 oz
to start outer brush moving.

CLUTCH LATCHLEVER SPRING

Requirement

With clutch tripped and latchlever resting on clutch disc as shown

Min 1-1/4 oz---Max 2-1/4 oz
to start clutch latchlever moving.

2.09 Distributor Area (continued)

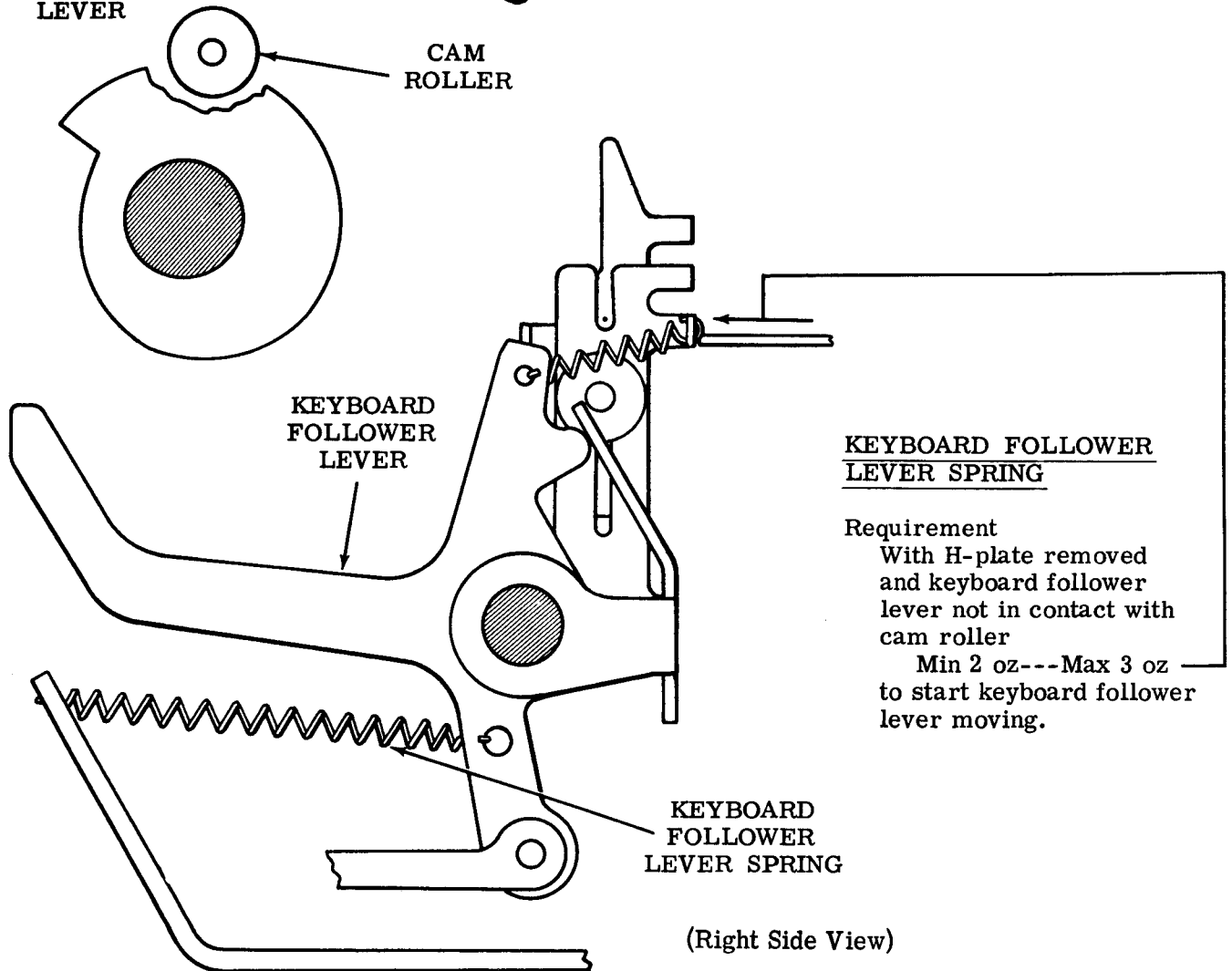
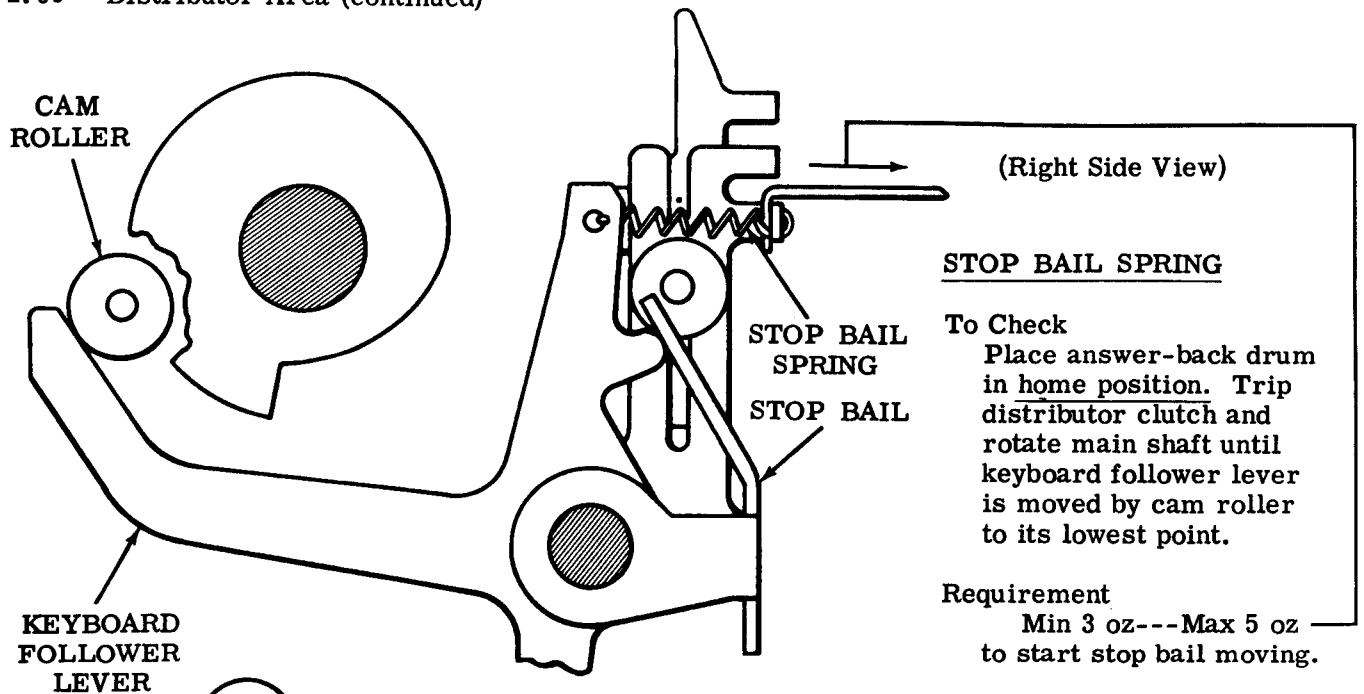

2.10 Main Shaft Area

Note: If a complete readjustment of the typing unit is to be performed, loosen all screws on main shaft except collar screw immediately to the right of the left main shaft bearing.

(A) LEFT BEARING POSITION**Requirement**

The start cam follower, selector levers, and spacing locklever should fully engage their cams when cam sleeve is in contact with the left bearing, and the left side of the left bearing should protrude beyond selector side plate.

To Adjust

Loosen left bearing clampscrews and position left bearing. Tighten clampscrews.

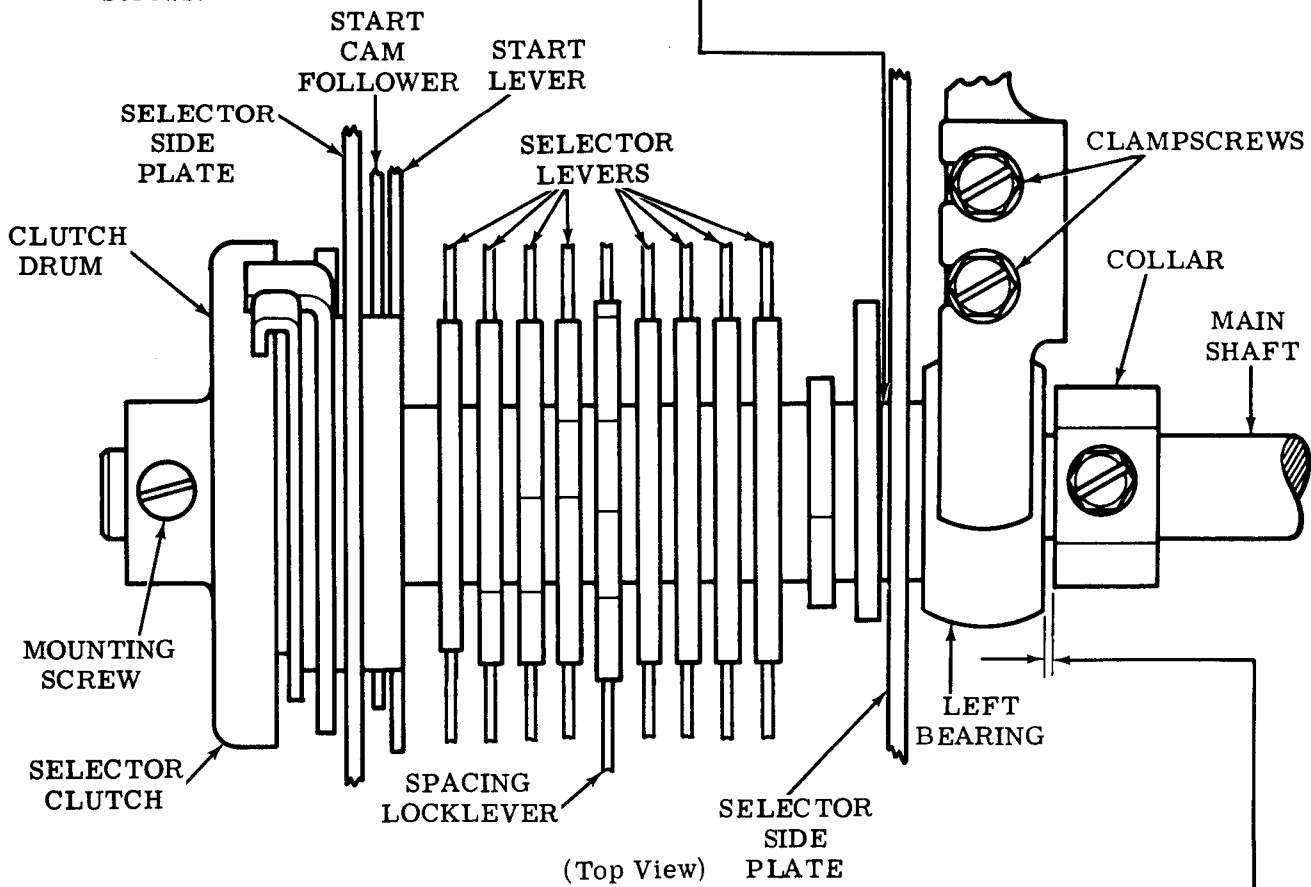
**Related Adjustments****Affects**

FUNCTION SHAFT AND CASTING POSITION (2.40)
DRIVEN GEAR LINE-UP (2.12)
CODEBAR CLUTCH TRIP LEVER LINE-UP (2.13)

(B) SELECTOR CAM ENDPLAY**To Check**

Disengage (latch) selector clutch. Take up play in main shaft toward right.

Requirement

Min some---Max 0.015 inch endplay between left bearing and collar.

To Adjust

With the selector clutch drum mounting screw friction tight, position the clutch drum. Tighten mounting screw.

Related Adjustments**Affects**

DRIVEN GEAR LINE-UP (2.12)
CODEBAR CLUTCH TRIP LEVER LINE-UP (2.13)

2.11 Main Shaft Area (continued)

Note: Adjustment (A) is to be done only when completely readjusting the typing unit.

(A) FUNCTION CLUTCH POSITION
(Preliminary)

To Check

Take up play to minimize clearance between carriage drive eccentric and end of roller shaft.

Requirement

Min 0.020 inch---Max 0.040 inch clearance between carriage drive eccentric and end of roller shaft as gauged by eye.

To Adjust

Loosen the left and right function casting clampscrews (do not loosen the center clampscrew) friction tight and align the left side of lower portion of function casting with left side of lower projection of codebar basket rear tie bar by moving function casting. Loosen drum mounting screw and position function clutch to meet requirement. Tighten drum mounting screw.*

To Check

Disengage (latch) function clutch. Take up clearances to make function clutch endplay a maximum.

Requirement

Min 0.005 inch---Max 0.015 inch endplay in function clutch.

To Adjust

Loosen collar clampscrew and position function clutch to meet requirement. Tighten clampscrew.

Related Adjustment Affected By

FUNCTION CLUTCH POSITION (2.11)

(Left Front View)

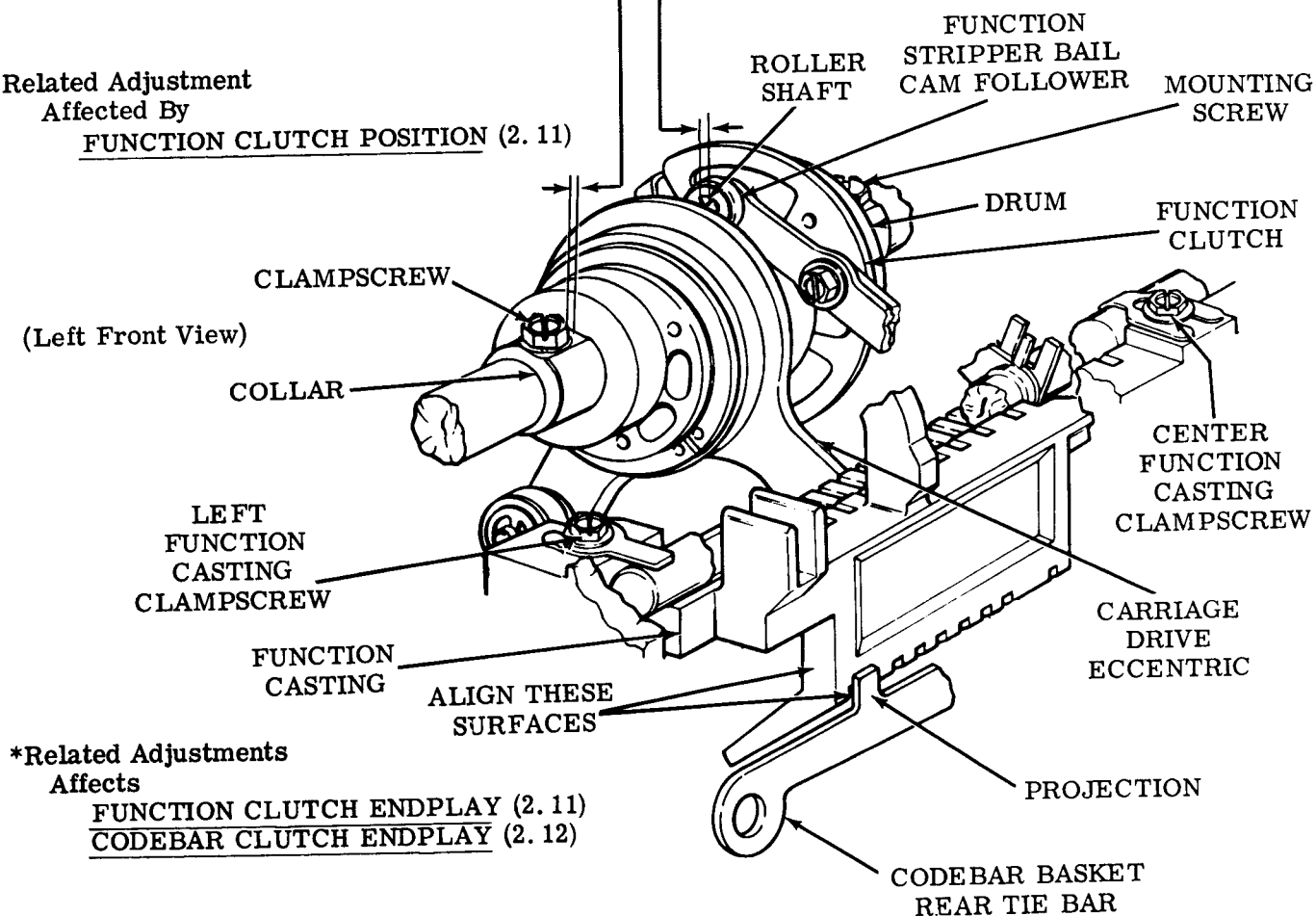

*Related Adjustments Affects

FUNCTION CLUTCH ENDPLAY (2.11)
CODEBAR CLUTCH ENDPLAY (2.12)

2.12 Main Shaft Area (continued)

CODEBAR CLUTCH ENDPLAY

To Check

Disengage (latch) codebar clutch. Take up clearances to make codebar clutch endplay a maximum.

Requirement

Min 0.005 inch---Max 0.015 inch endplay in codebar clutch.

To Adjust

Loosen codebar clutch mounting screw and position codebar clutch to meet requirement. Tighten codebar clutch mounting screw.

Related Adjustments

Affects

- CODEBAR CLUTCH TRIP LEVER LINE-UP (2.13)
- CODEBAR RESET LEVER LINE-UP (2.27)

Affected By

- FUNCTION CLUTCH POSITION (2.11)

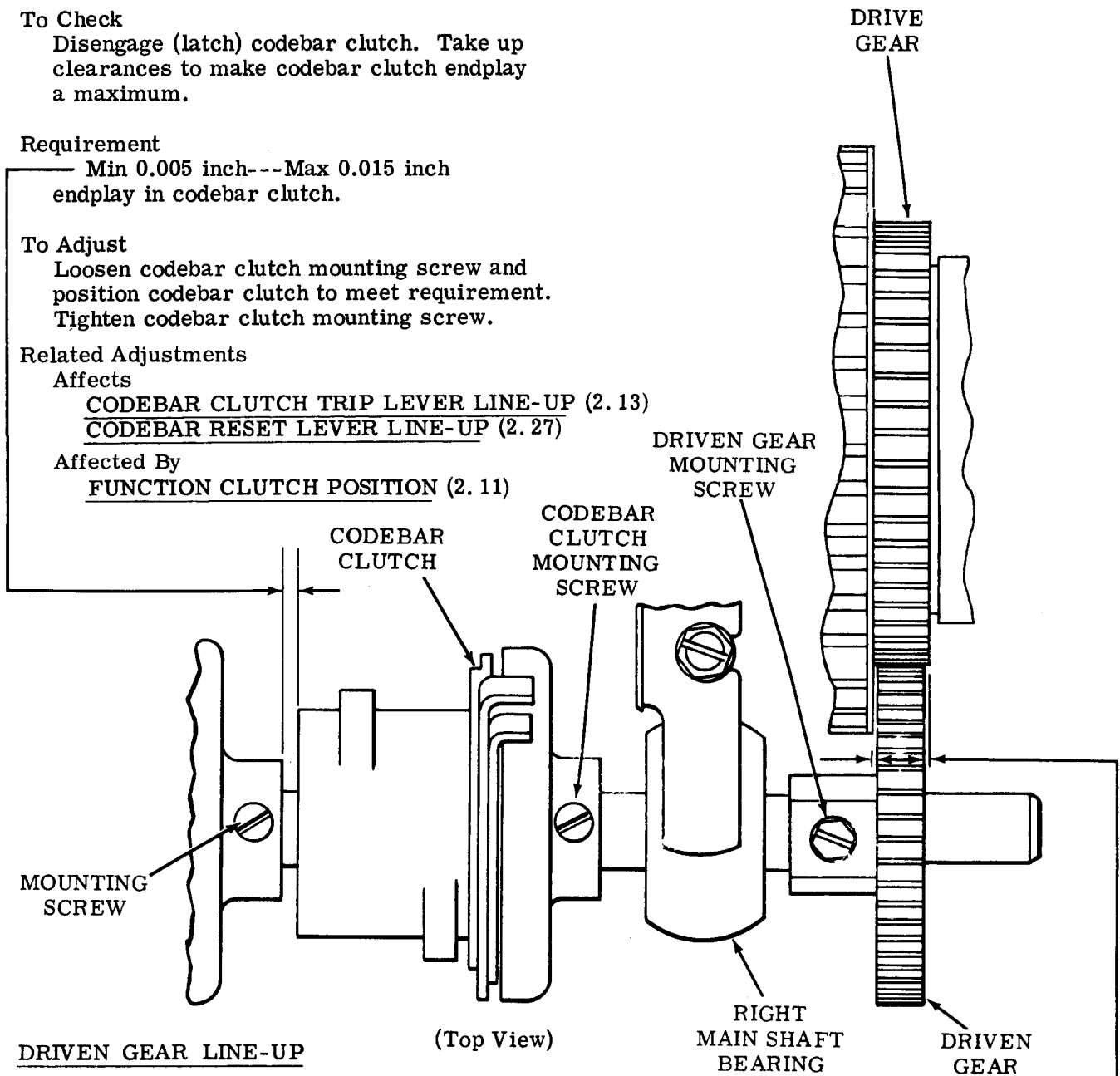

DRIVEN GEAR LINE-UP

(Top View)

Requirement

Driven gear centered on drive gear as gauged by eye.

To Adjust

Loosen driven gear mounting screw, and position driven gear to meet requirement. Tighten driven gear mounting screw.

Related Adjustments

Affected By

- LEFT BEARING POSITION (2.10)
- BRUSH HOLDER GAP (2.03)
- SELECTOR CAM ENDPLAY (2.10)

2.13 Main Shaft Area (continued)

CODEBAR CLUTCH TRIP LEVER LINE-UP

(1) Requirement

As gauged by eye, codebar clutch trip lever approximately aligned with shoe lever

within 0.030 inch.

(2) Requirement

Min 0.005 inch between function clutch trip roller's shaft and codebar reset cam when all play is taken up to make clearance minimum.

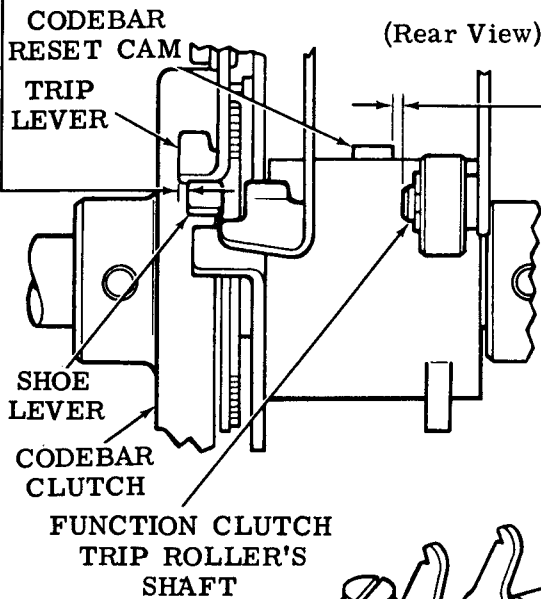

CLAMPSCREW

LATCHLEVER

CODEBAR RESET CAM

TRIP LEVER

SHOE LEVER

CODEBAR CLUTCH

(Right Rear View)

FUNCTION CLUTCH

To Adjust

Loosen clampscrew and position trip lever.

Note: It may also be necessary to loosen setscrew in collar.

Related Adjustments

Affects

TRIP SHAFT LATCHLEVER ENDPLAY (2.13)

CODEBAR CLUTCH TRIP LEVER ENGAGEMENT (2.14)

Affected By

LEFT BEARING POSITION (2.10)

SELECTOR CAM ENDPLAY (2.10)

CODEBAR CLUTCH ENDPLAY (2.12)

TRIP SHAFT LATCHLEVER ENDPLAY

Requirement

Min some---Max 0.012 inch endplay in latchlevers, as gauged by eye.

To Adjust

Loosen setscrew and position collar. Tighten setscrew. On units with TP186731 compression ring, compress ring tabs and position ring. Clearance to be measured between function clutch latchlever and trip lever.

SETScrew

COLLAR

FUNCTION CLUTCH TRIP ROLLER'S SHAFT

TRIP LEVER

LATCHLEVER

Related Adjustments

Affected By

CODEBAR CLUTCH TRIP LEVER LINE UP (2.13)

2.14 Main Shaft Area (continued)

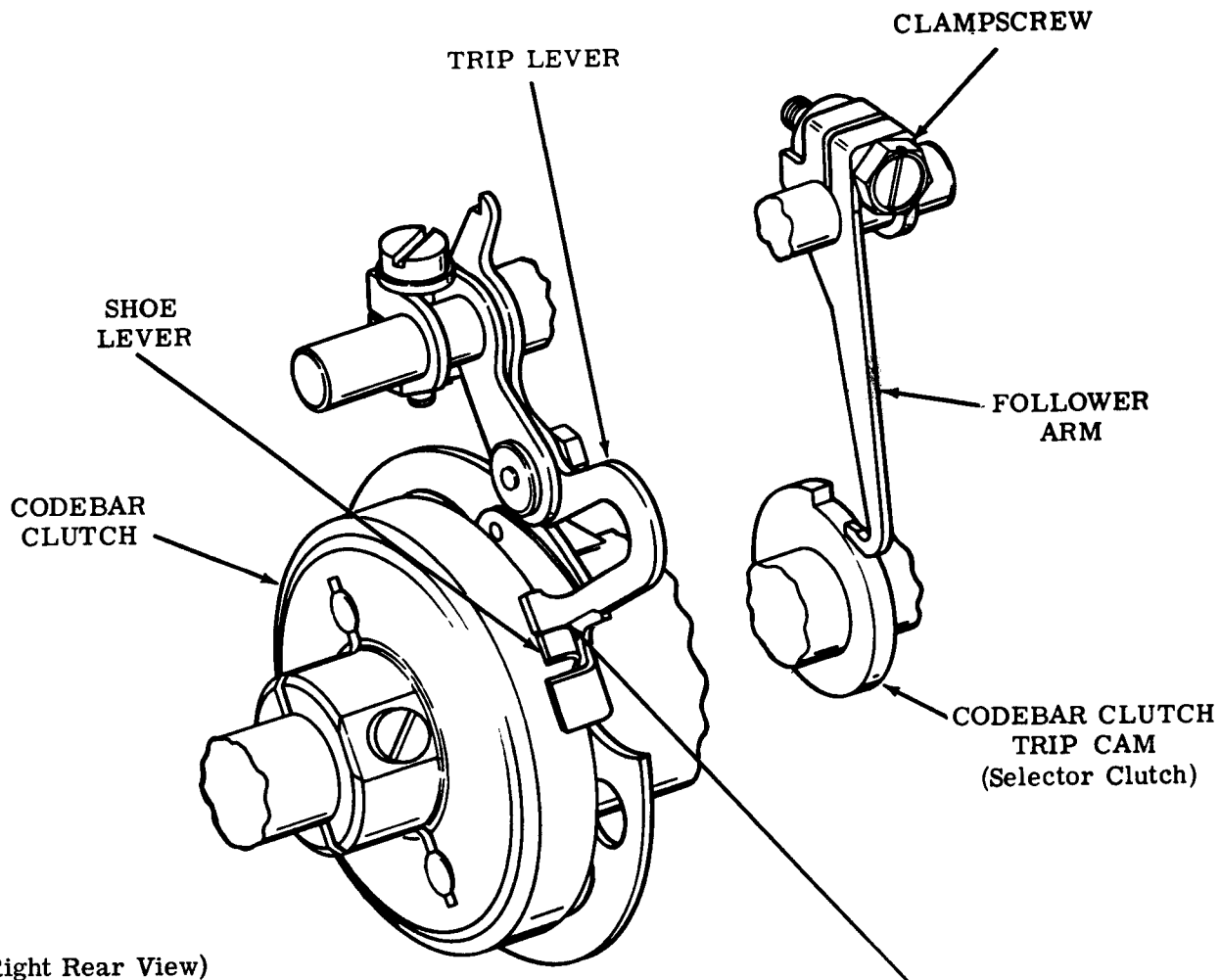

2.15 Main Shaft Area (continued)

TRIP LEVER SPRINGS

Note: Check for both codebar and function clutches.

Requirement

With clutch engaged, codebar clutch

Min 6 oz---Max 12 oz

function clutch

Min 2 oz---Max 4 oz

to start trip lever moving.

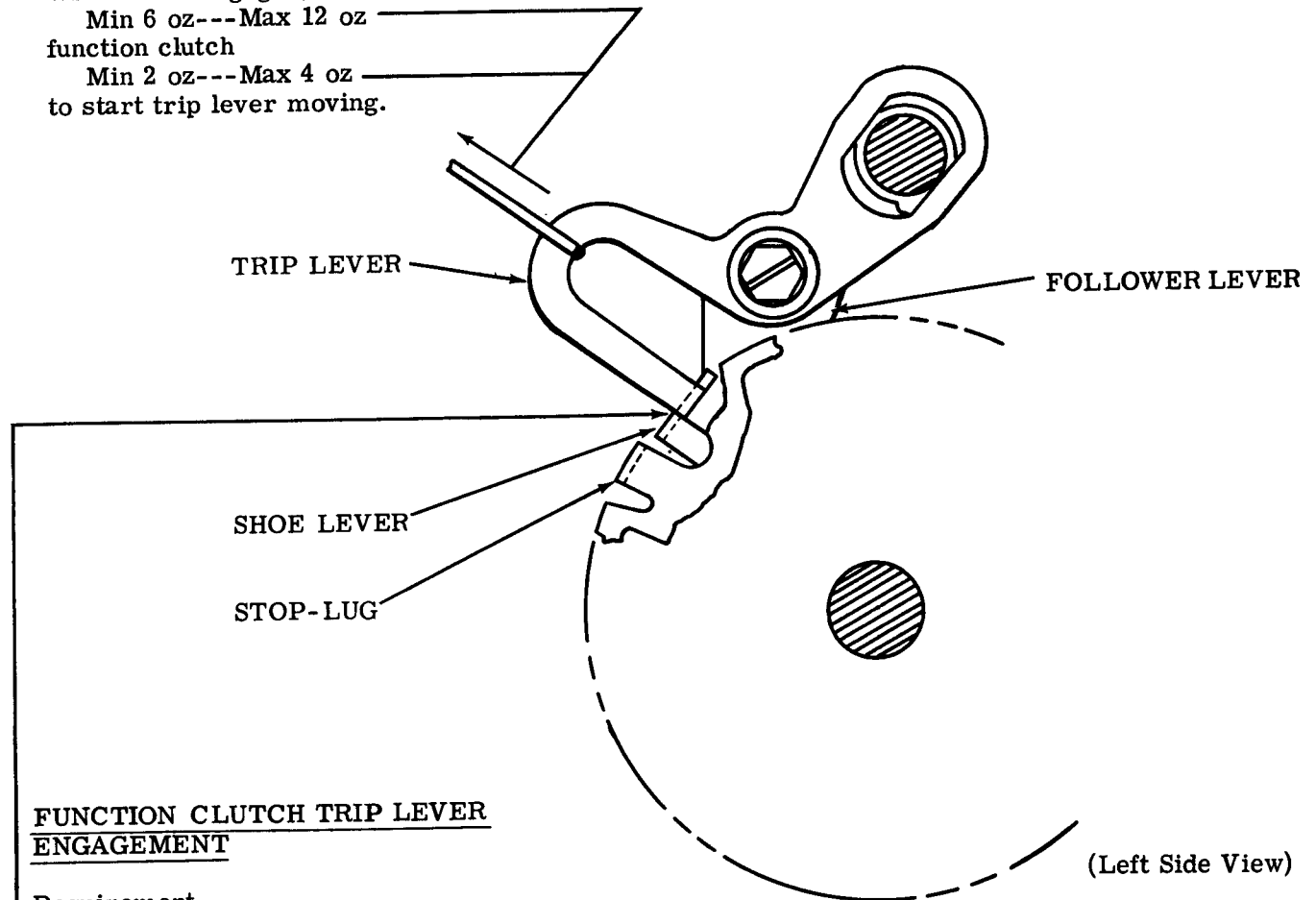

Requirement

With typing unit in stop condition, trip lever should engage shoe lever by approximately full thickness of shoe lever.

To Adjust

Loosen clampscrew and position follower lever. Tighten clampscrew.

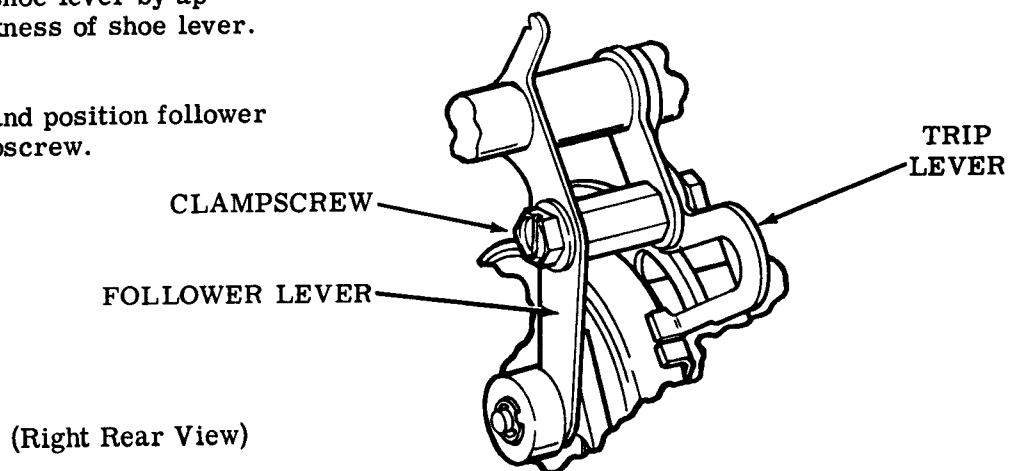

2.16 Main Shaft Area (continued)

CODEBAR AND FUNCTION CLUTCH SHOE LEVER GAPS

(1) To Check

Disengage (latch) clutch. Trip clutch by lifting trip lever. Permit trip lever to come to rest on shoe lever. Fully seat clutch shoes by applying slight pressure against shoe lever along its normal path of forward travel.

Requirement

Min 0.055 inch---Max 0.085 inch between edge of trip lever and edge of shoe lever.

Note: On typing units with either a scribed line or a notch on the trip lever, gauge by eye the alignment of the scribed line or notch and the front edge of the shoe lever. They are to line up.

(2) To Check

Disengage (latch) clutch.

Requirement

Min 0.015 inch between shoe lever and stop-lug.

To Adjust

Loosen clampscrew. Lengthen or shorten trip lever clearance to meet requirement. Tighten clampscrew.

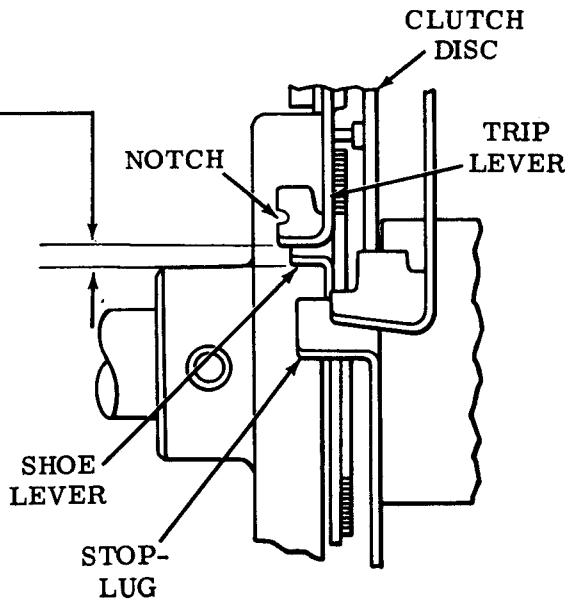

(Rear View)

CODEBAR AND FUNCTION CLUTCH LATCHLEVER SPRINGS

Requirement

With latchlever resting on high portion of clutch disc

Min 2 oz---Max 3 oz to start latchlever moving.

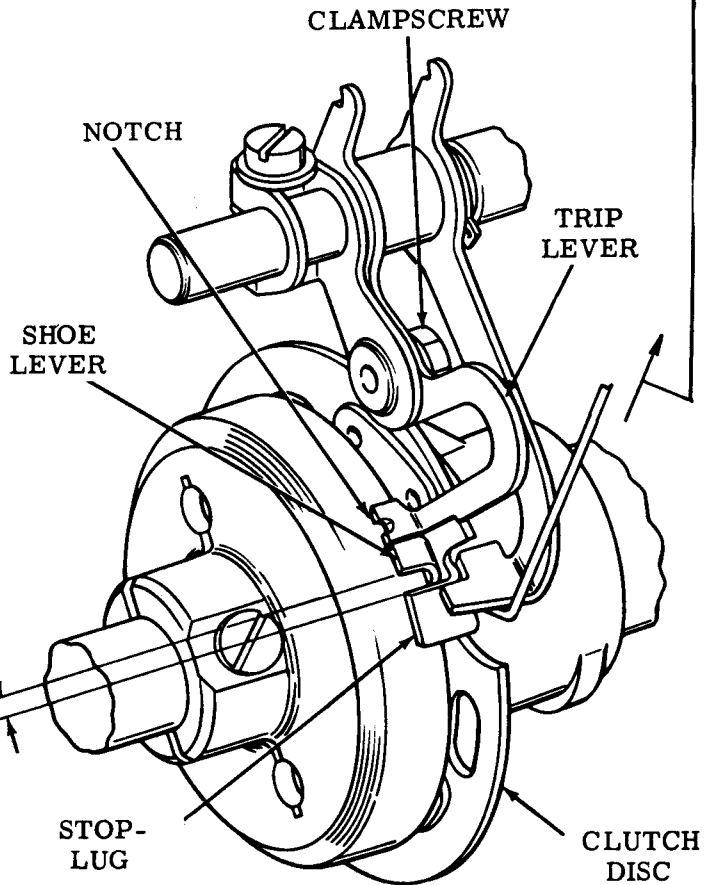

(Right Rear View)

2.17 Main Shaft Area (continued)

Note 1: These tensions apply to all clutches.

CLUTCH SHOE LEVER SPRING

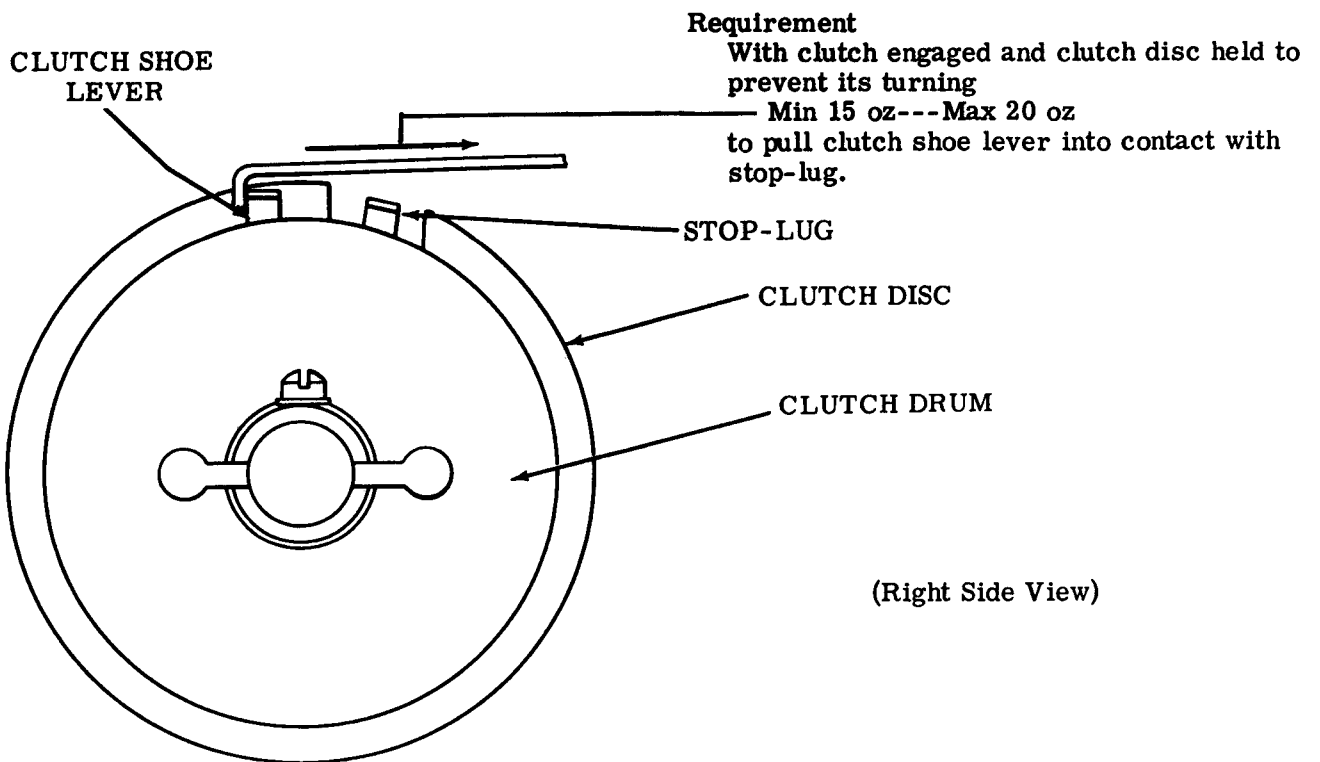

(Right Side View)

CLUTCH SHOE SPRING

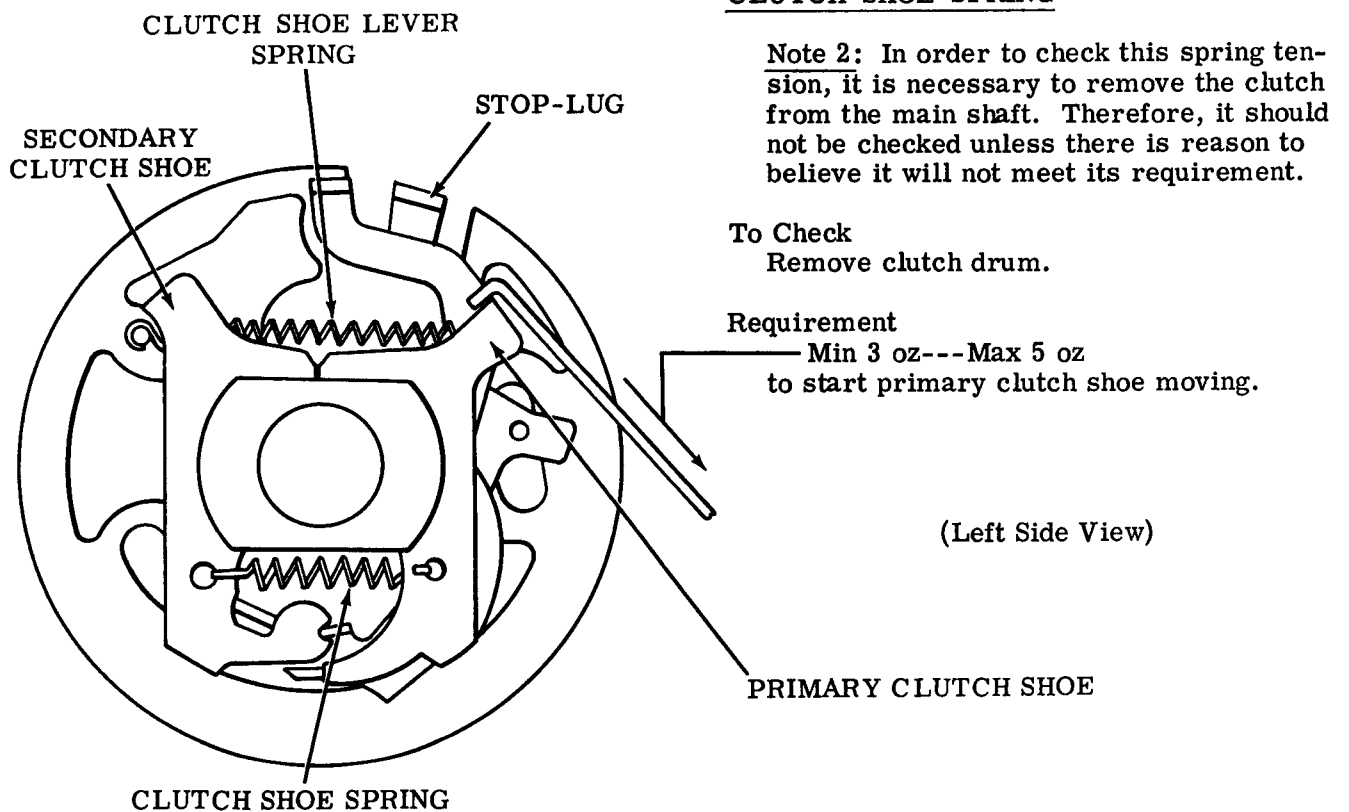

Note 2: In order to check this spring tension, it is necessary to remove the clutch from the main shaft. Therefore, it should not be checked unless there is reason to believe it will not meet its requirement.

To Check
Remove clutch drum.

(Left Side View)

2.18 Selector Area

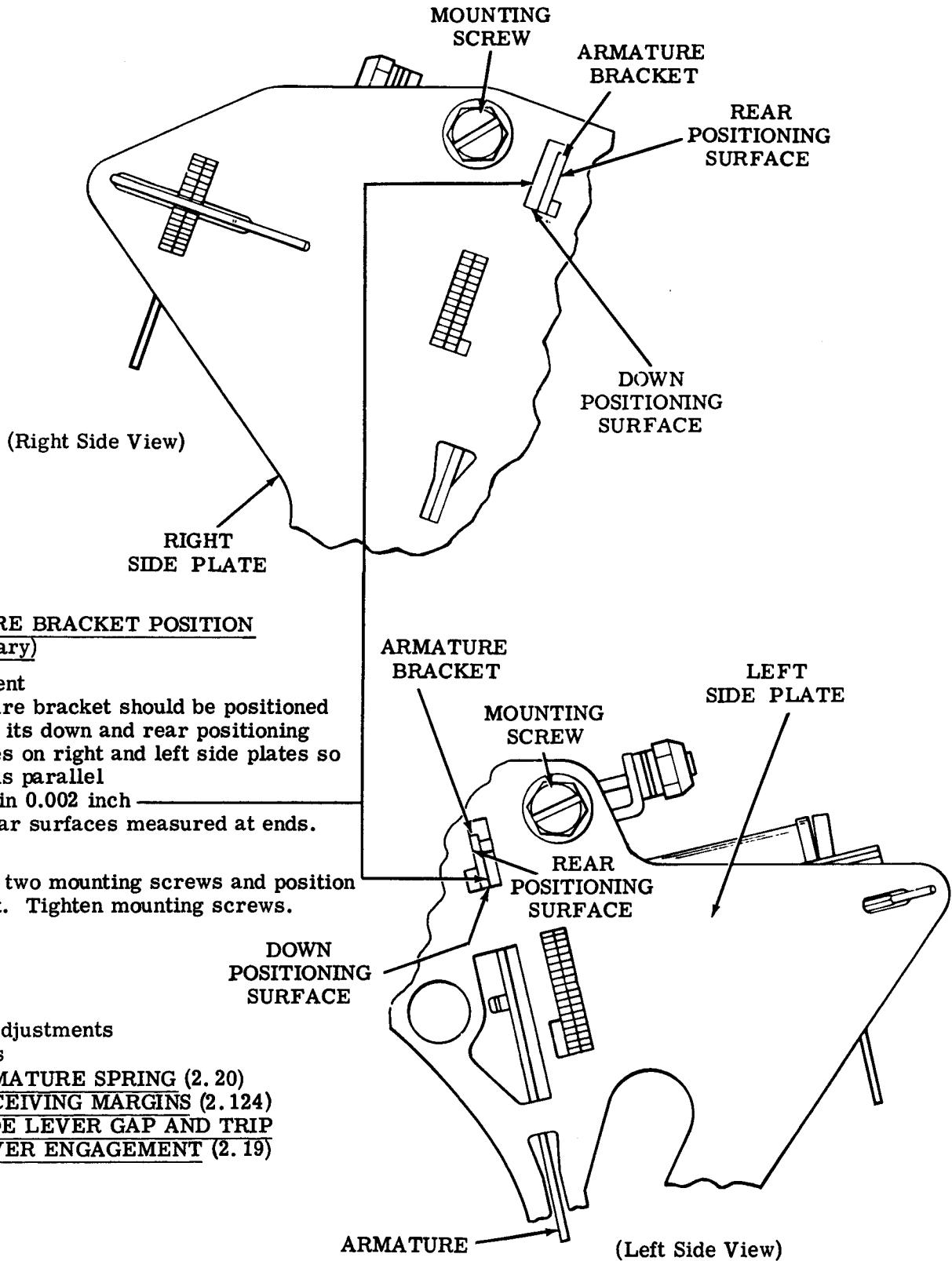

ARMATURE BRACKET POSITION
(Preliminary)

Requirement

Armature bracket should be positioned against its down and rear positioning surfaces on right and left side plates so that it is parallel within 0.002 inch with rear surfaces measured at ends.

To Adjust

Loosen two mounting screws and position bracket. Tighten mounting screws.

Related Adjustments

Affects

- ARMATURE SPRING (2.20)
- RECEIVING MARGINS (2.124)
- SHOE LEVER GAP AND TRIP LEVER ENGAGEMENT (2.19)

2.19 Selector Area (continued)

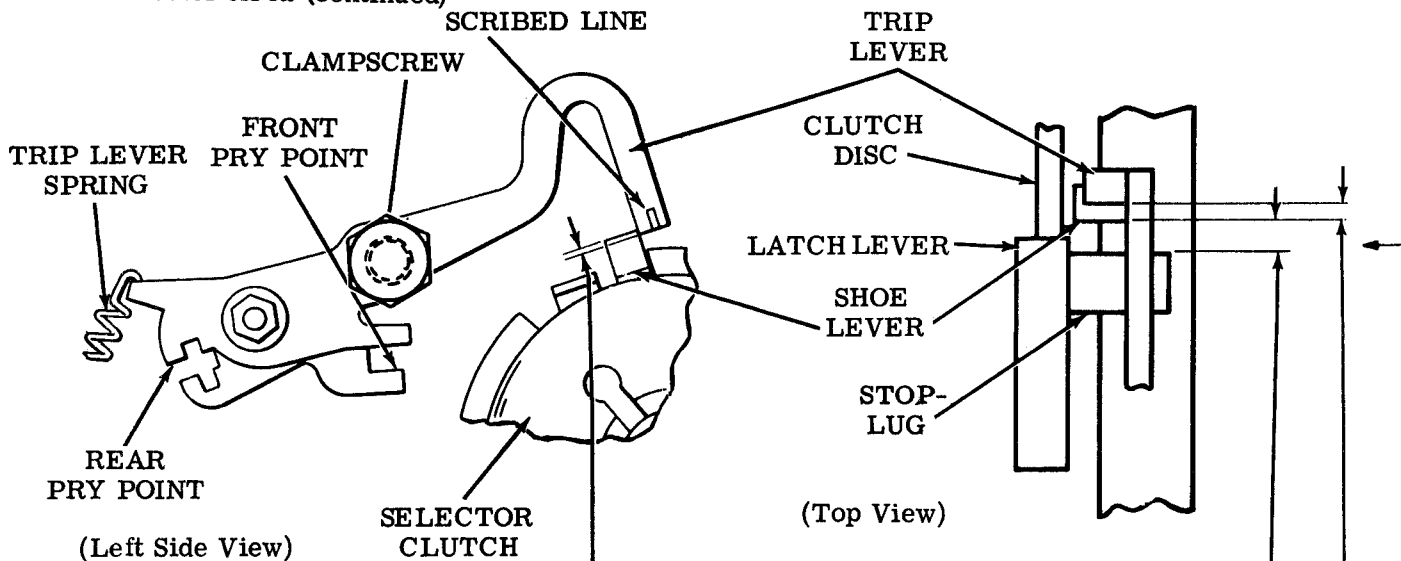

TRIP LEVER SPRING

Requirement

With typing unit in stop condition and shoe lever held away from trip lever
 Min 6 oz---Max 7-3/4 oz
 to start trip lever moving.

Note 1: Start lever and latchlever springs also influence this spring tension. Check them individually if above requirement is not met. If they meet requirements, replace trip lever spring.

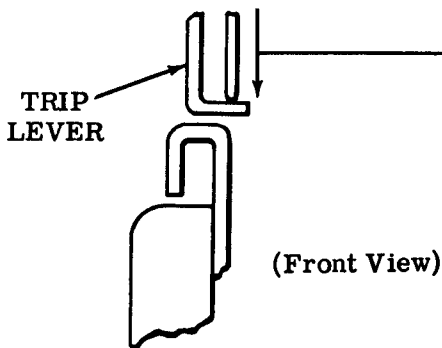

SHOE LEVER GAP AND TRIP LEVER ENGAGEMENT

(1) To Check

Set up an all-spacing code in selector. Manually latch selector clutch by rotating clutch disc counter clockwise. Trip selector clutch. Apply slight pressure on trip lever to fully seat clutch shoes.

Requirement

Min 0.055 inch---Max 0.085 inch
 between edge of trip lever and edge of shoe lever.

(2) To Check

Manually seat selector clutch by rotating clutch disc counterclockwise against latchlever.

Requirement

Min 0.015 inch
 between shoe lever and stop-lug.

(3) To Check

Disengage (latch) selector clutch.

Requirement

Trip lever should engage shoe lever
 Min 2/3 thickness
 of shoe lever.

To Adjust

Loosen clampscrew friction tight and position trip lever using front and/or rear pry points. Tighten clampscrew.

Related Adjustments

Affects

RECEIVING MARGINS (2.124)

Affected By

ARMATURE BRACKET POSITION (2.18)

Note 2: On typing units with either a scribed line or a notch on the trip lever, gauge by eye the alignment of the scribed line or notch and the front edge of the shoe lever. They are to line up.

2.20 Selector Area (continued)

ARMATURE SPRING

Note: This is a preliminary adjustment. It should not be considered final until RECEIVING MARGINS (2.124) adjustment is completed, and, as finally adjusted, it could fall outside limits specified below.

To Check

Place typing unit in stop condition and move carriage near right margin. Remove armature clip. Rotate selector clutch until start lever, selector levers, and spacing locklever do not contact armature.

Requirement

Min 2-1/4 oz---Max 4-3/4 oz _____
to pull armature to midpoint of travel.

To Adjust

Rotate adjusting nut clockwise to increase armature spring tension and counter-clockwise to decrease it.

Related Adjustments

Affects

RECEIVING MARGINS (2.124)

Affected By

ARMATURE BRACKET POSITION (2.18)

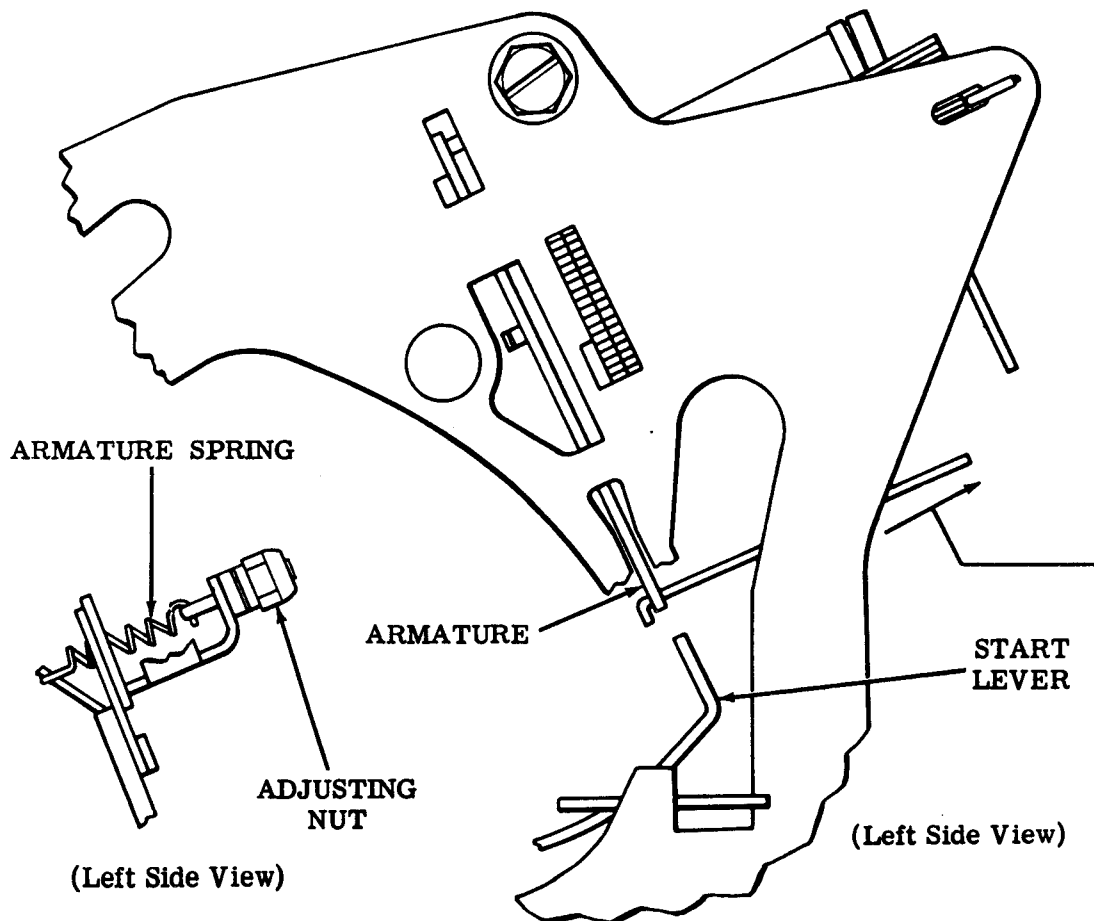

2.21 Selector Area (continued)

START LEVER SPRING

Requirement

With typing unit in stop condition

Min 19 oz---Max 23 oz

to pull start lever spring to installed length.

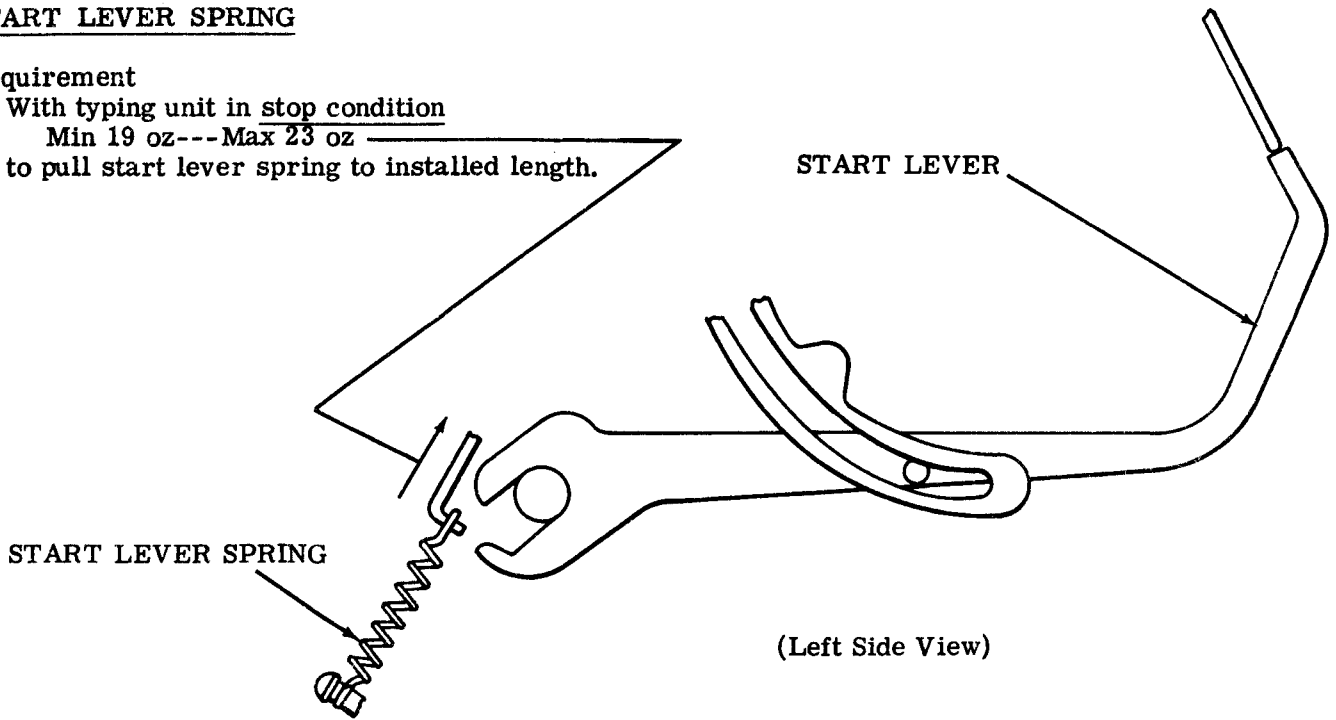

LATCHLEVER SPRING

Requirement

With selector latchlever resting on high part of clutch disc

Min 2 oz---Max 3 oz

to start selector latchlever moving.

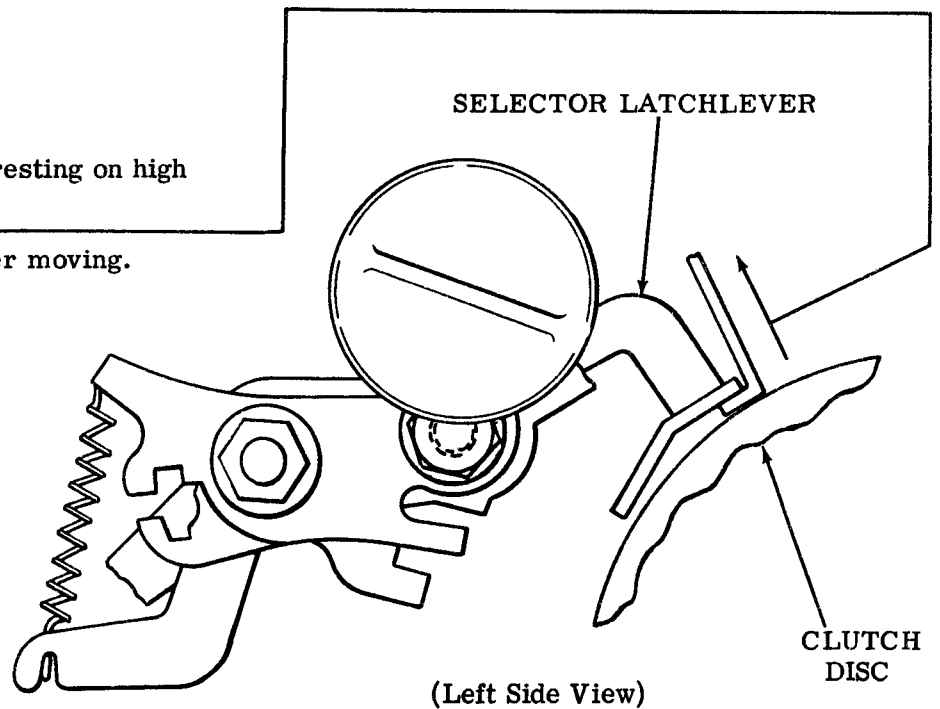

2.22 Selector Area (continued)

SELECTOR LEVER SPRINGS

To Check

Set up NUL, an all spacing code combination, in selector. Rotate main shaft until typing unit is in stop condition.

Requirement

Min 1-1/2 oz---Max 3-1/4 oz to start selector lever moving.

Note: Check each selector lever spring.

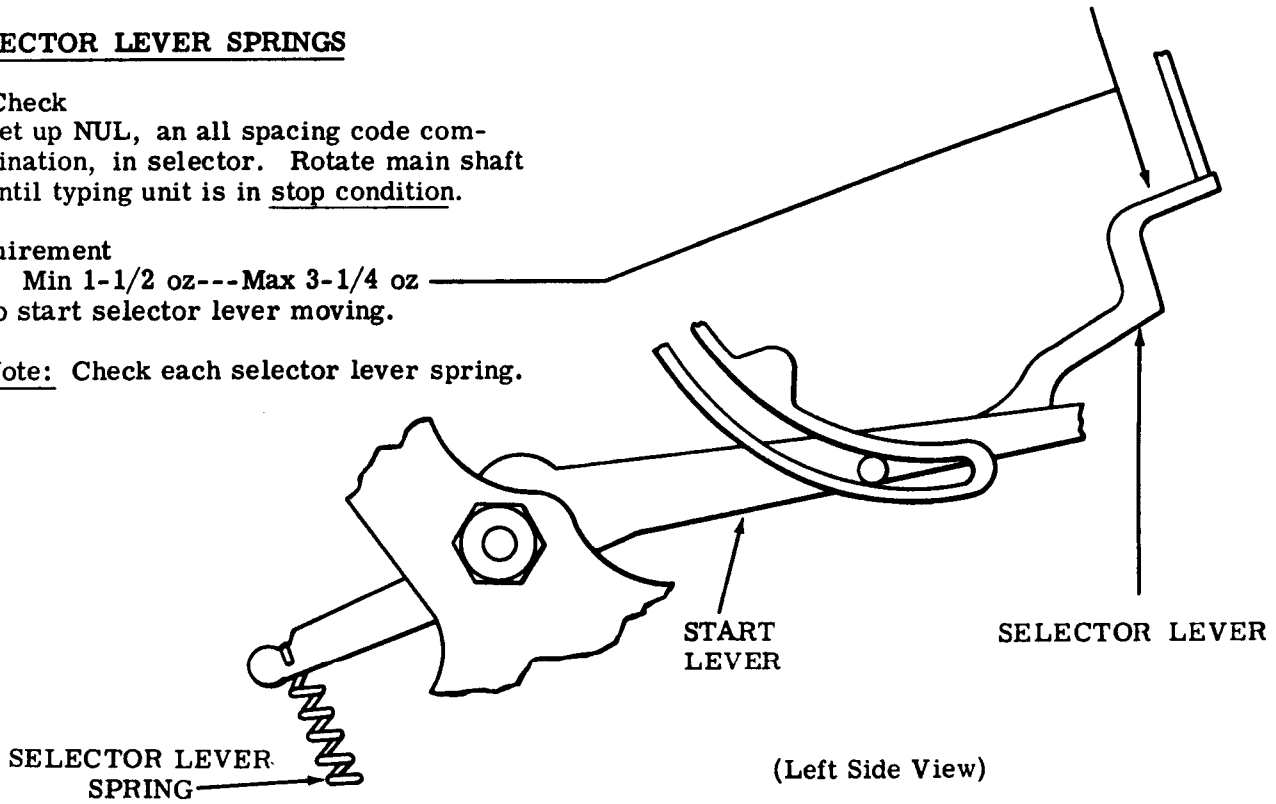

SPACING LOCKLEVER SPRING

To Check

Set up NUL, an all spacing code combination, in selector. Rotate main shaft until typing unit is in stop condition.

Requirement

Min 1-1/2 oz---Max 3 oz to start locklever moving.

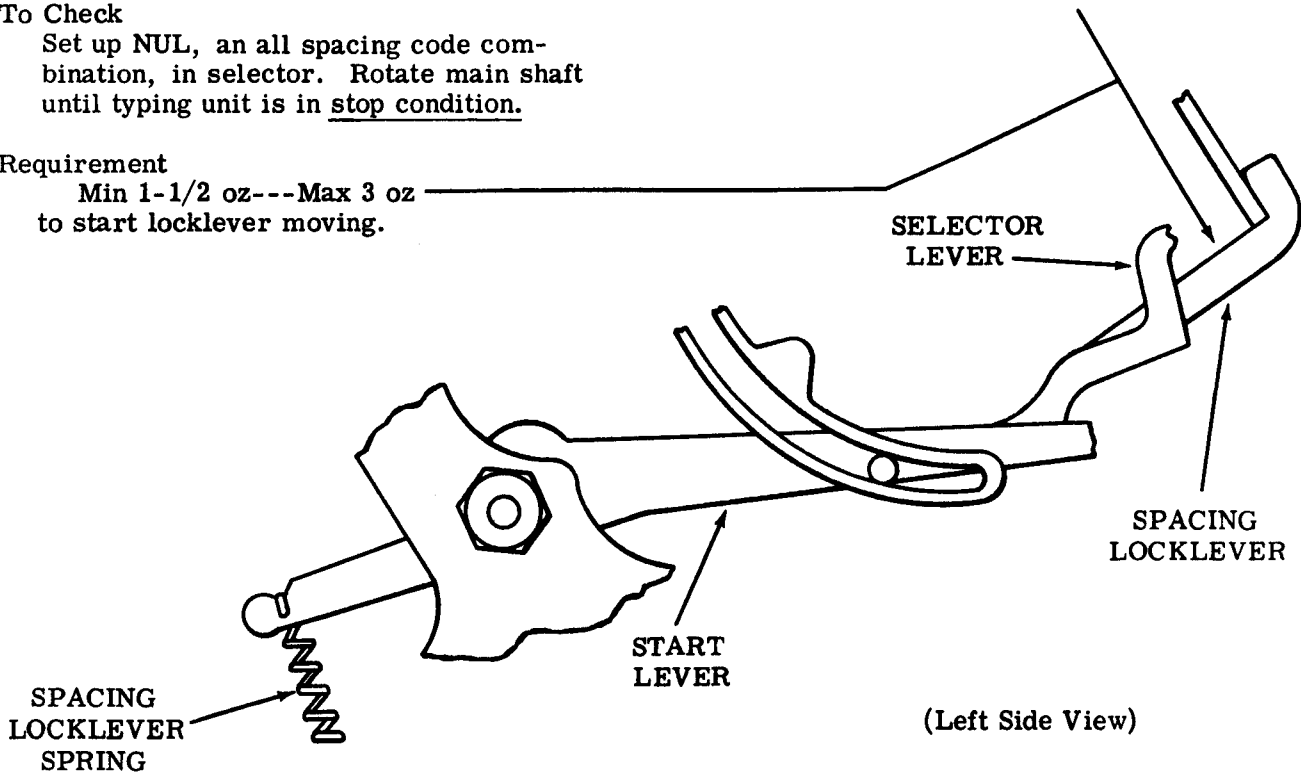

2.23 Selector Area (continued)

STRIPPER BAIL SPRING

To Check

Set range finder at 60. Set up NUL, an all spacing code combination, in selector. Rotate main shaft until typing unit is in stop condition.

Requirement

Min 1/4 oz---Max 1 oz
to start stripper bail moving.

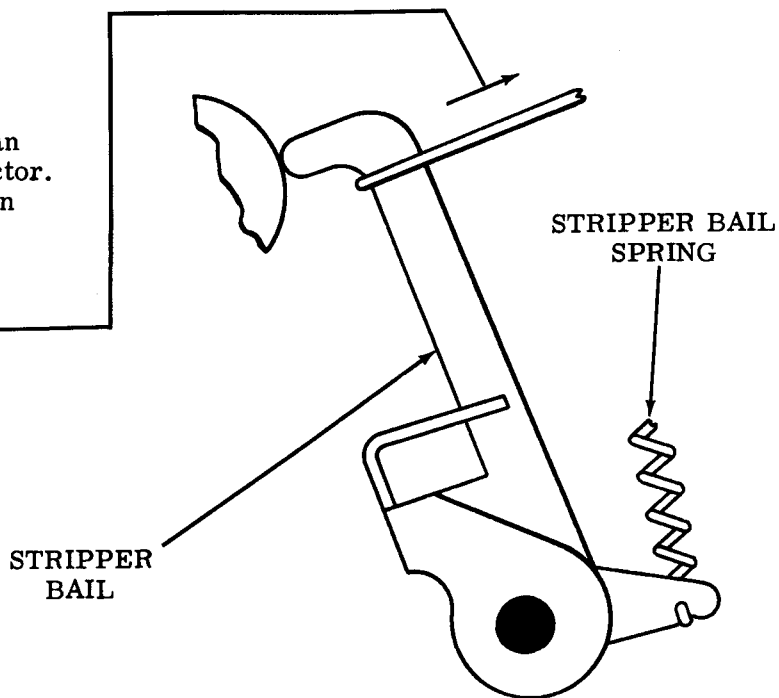

(Left Side View)

PUSH LEVER SPRINGS

Note 1: To measure this tension, selector mechanism must be removed from typing unit. Therefore, do not check it unless there is cause to suspect it will not meet requirement.

CAUTION: BEFORE REMOVING SELECTOR CLUTCH, MAKE SURE ARMATURE IS IN THE SPACING POSITION. HOLD SELECTOR LEVERS IN PLACE AWAY FROM SELECTOR CLUTCH WITH TP184098 TOOL.

Requirement

With blocking lever held away from push lever
Min 1-1/2 oz---Max 3 oz
to start push lever moving.

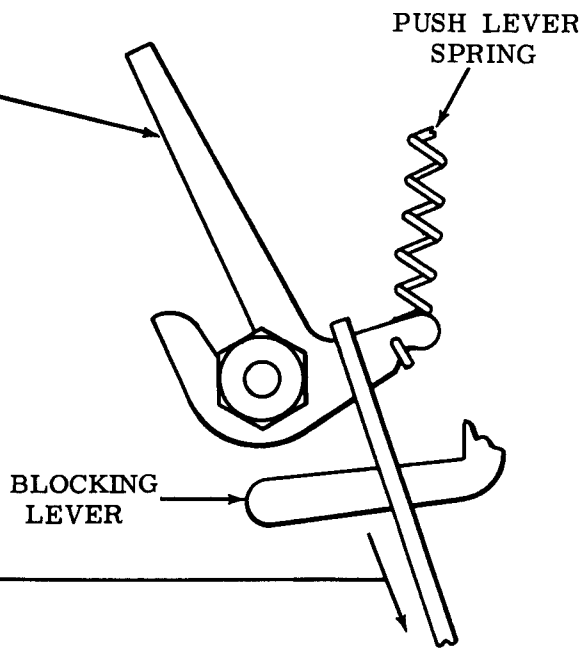

(Left Side View)

Note 2: Check each push lever spring.

2.24 Selector Area (continued)

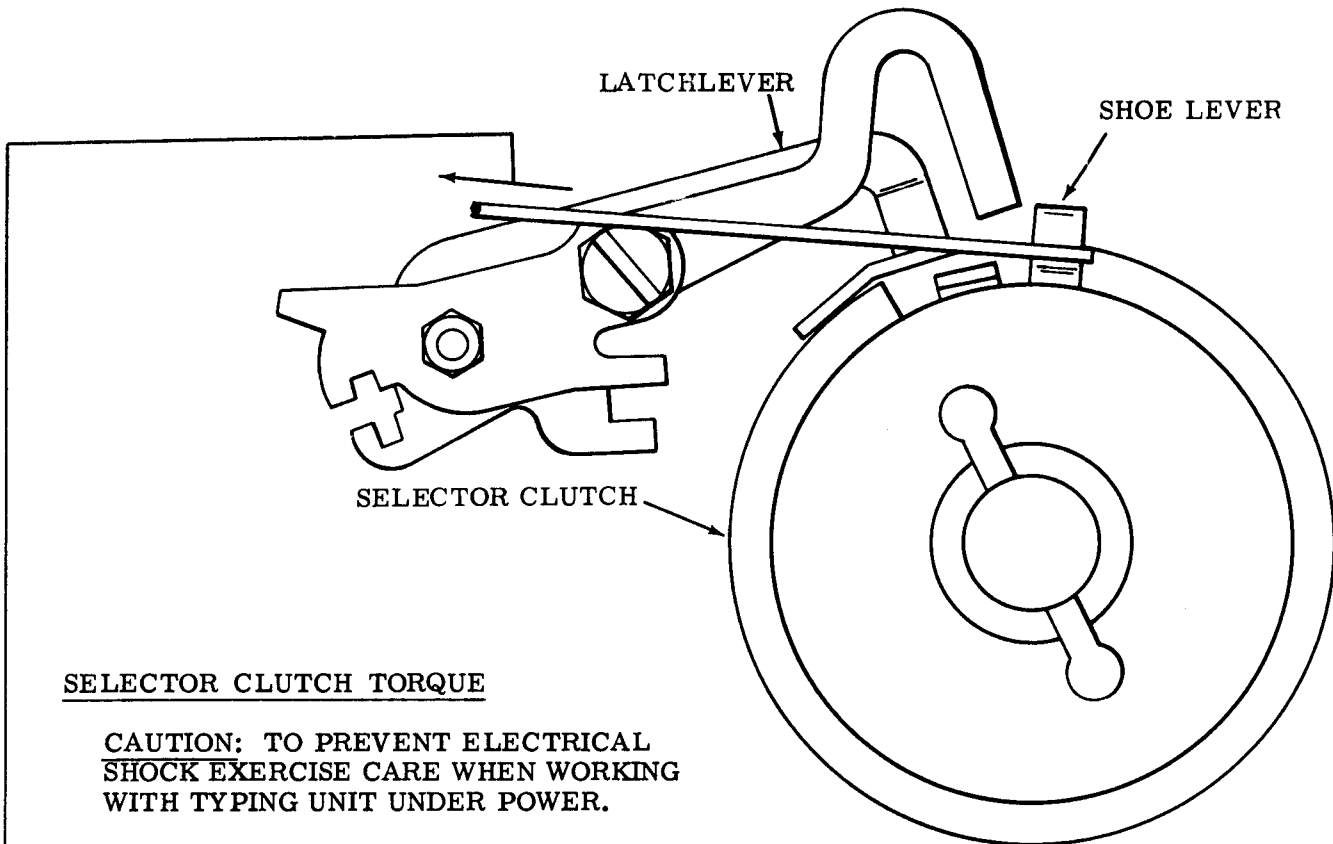

(Left Side View)

SELECTOR CLUTCH TORQUE

CAUTION: TO PREVENT ELECTRICAL SHOCK EXERCISE CARE WHEN WORKING WITH TYPING UNIT UNDER POWER.

To Check

Place TP185832 armature clip so as to hold armature attracted. Plug typing unit plugs into proper call control unit receptacle and apply power to typing unit. Hold shoe lever with spring scale as shown. Trip selector clutch by moving armature rearward. Allow selector clutch to advance until latchlever is disengaged. Check requirement. Remove all power connections.

Requirement

— Min 13 oz---Max 16 oz
to hold shoe lever.

2.25 Function Area

(A) MAIN SHAFT ROTATION

Note 1: This adjustment should be checked when adjustments affecting the typing unit drive system have been disturbed.

(1) To Check

With motor drive belt removed and all clutches disengaged (latched), manually rotate main shaft.

Requirement

No excessive drag or binding should be detected.

(2) To Check

With motor belt installed and all clutches disengaged (latched), manually rotate main shaft.

Requirement

No excessive drag or binding should be detected.

Note 2: Excessive drag or binding when the main shaft is rotated will cause insufficient receiving margins.

To Adjust

If requirements are not met, check following adjustments:

GEAR BACKLASH (Motor Area) (2.01)

BELT TENSION (Motor Area) (2.02)

LEFT BEARING POSITION (Main Shaft Area) (2.10)

SELECTOR CAM ENDPLAY (Main Shaft Area) (2.10)

FUNCTION CLUTCH ENDPLAY (Main Shaft Area) (2.11)

CODEBAR CLUTCH ENDPLAY (Main Shaft Area) (2.12)

DRIVEN GEAR LINE-UP (Main Shaft Area) (2.12)

FORM FEED CLUTCH ENDPLAY - S (Main Shaft Area) (2.93)

SHOE LEVER GAP AND TRIP LEVER ENGAGEMENT (Selector Area) (2.19)

BEARING ALIGNMENT (2.25)

(B) BEARING ALIGNMENT

Note 3: This adjustment applies to main shaft bearings, distributor shaft bearings, function rocker shaft bearings, and codebar reset bail bearings. It should only be made if bearing clamps have been loosened, or if a bind is detected in associated shafts.

Requirement

Bearings should be aligned with their respective shaft.

To Adjust

(a) With bearing clamps loosened, position bearing using finger pressure while rotating associated shaft. Tighten clampscrews.

(b) If bind still exists, keep bearing clamp tightened and apply a light blow vertically to top of bearing clamp.

2.26 Function Area (continued)

ROCKER SHAFT POSITION AND ENDPLAY

(1) Requirement

Both bearings should be centered on base casting, as gauged by eye.

To Adjust

Loosen collar setscrews and bearing clampscrews and position bearings.
Tighten bearing clampscrews.

(2) Requirement

The left end of function rocker shaft should line up with inside top edge of base casting lip, however:

0.030 inch misalignment is permissible to the left.

0.060 inch misalignment is permissible to the right.

(3) Requirement

Min some---Max 0.010 inch
endplay in function rocker shaft.

To Adjust

Loosen setscrews and position function rocker shaft and both collars.
Tighten both setscrews.

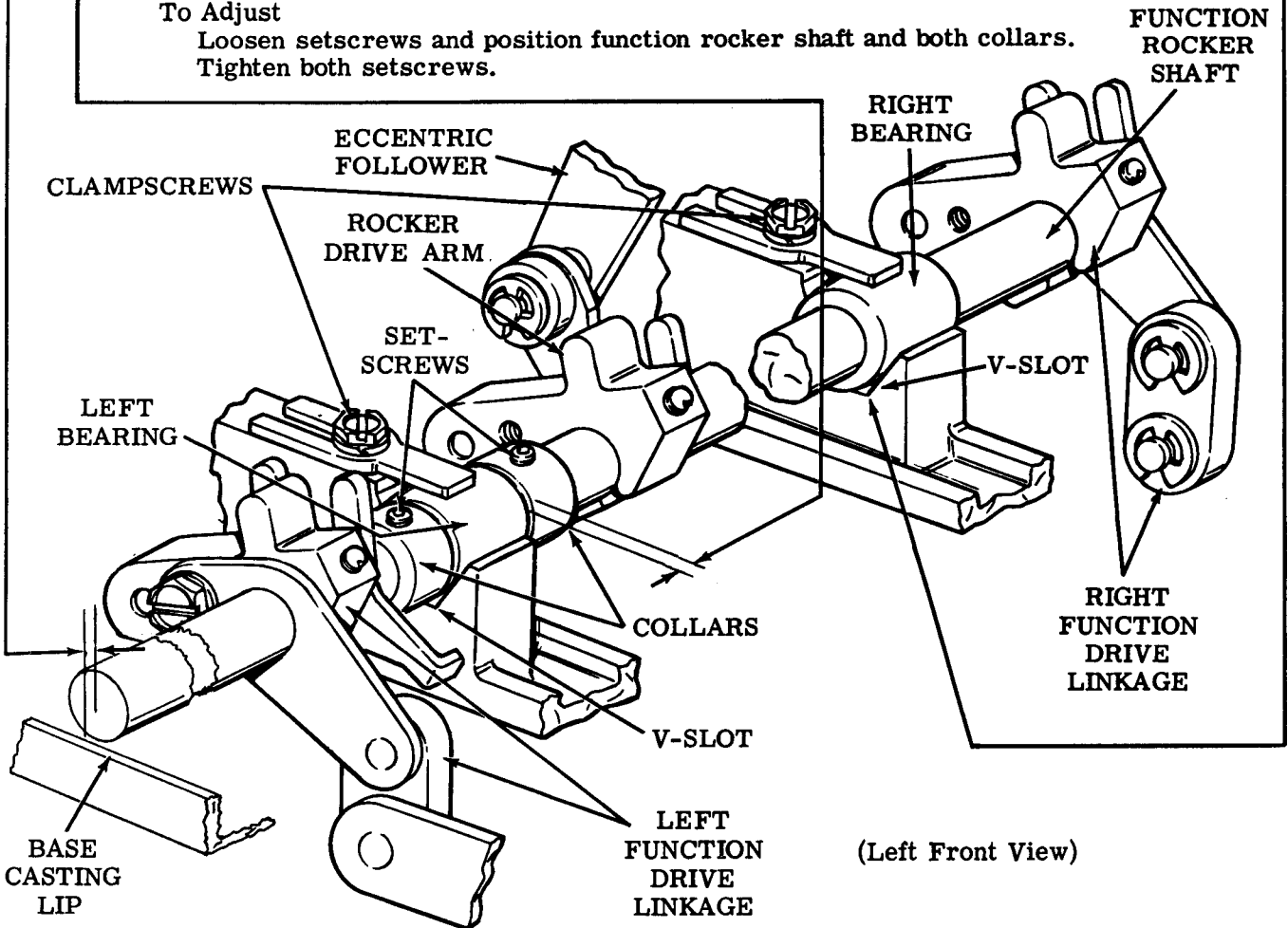

(Left Front View)

Related Adjustments
Affects

CODEBAR RESET LEVER LINE-UP (2.27)

CODEBAR RESET LEVER POSITION (2.28)

PRINT SUPPRESSION LATCH — HORIZONTAL CLEARANCE (2.29)

2.27 Function Area (continued)

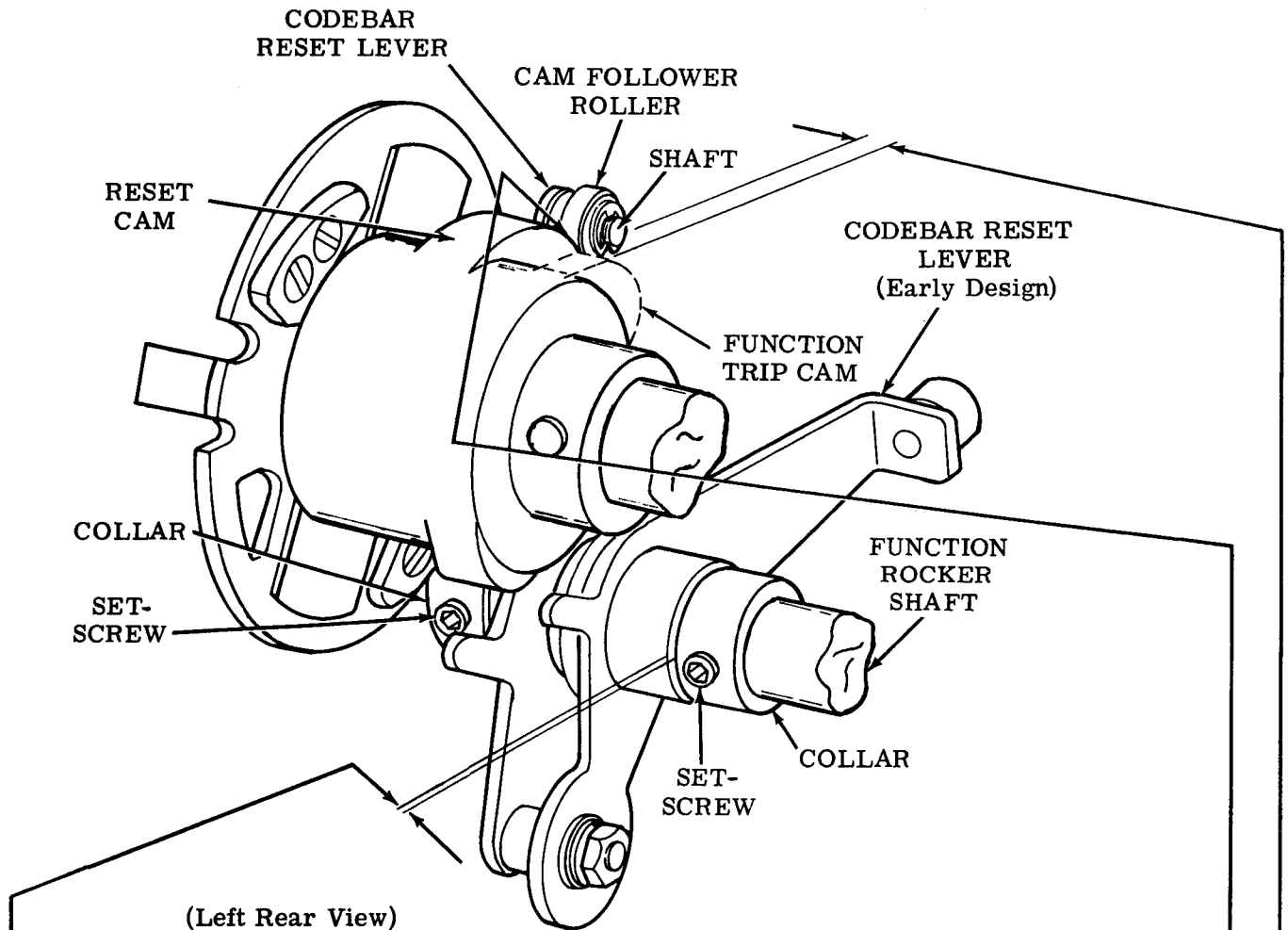
CODEBAR RESET LEVER LINE-UP**Requirement**

With typing unit in stop condition

- (1) Cam follower roller approximately centered on reset cam, as gauged by eye,
Max 0.020 inch _____
overhang permitted on right side only.
- (2) Min some---Max 0.010 inch
endplay in codebar reset lever.
- (3) Min 0.005 inch _____
between cam follower roller's shaft and function trip cam.

To Adjust

Loosen setscrews and position two collars.

Related Adjustments**Affects**

CODEBAR RESET LEVER POSITION (2. 28)

Affected By

ROCKER SHAFT POSITION AND ENDPLAY (2. 26)

CODEBAR CLUTCH ENDPLAY (2. 12)

2.28 Function Area (continued)

NO. 8 CODEBAR

SELECTOR
BLOCKING LEVER

SELECTOR
BLOCKING LEVER

SET-
SCREW

CODEBAR
RESET LEVER

(Left Rear View)

SETSCREW

PRY POINT

CLAMP NUT

(Late design units have adjusting screw.)

(Left Side View)

NO. 8
CODEBAR

CODEBAR RESET LEVER POSITION

To Check

Place typing unit in stop condition. Push selector stripper bail towards front of typing unit to permit blocking levers to assume their spacing position. Take up play between no. 8 codebar and its associated blocking lever so as to make clearance a minimum.

Requirement

Min 0.012 inch---Max 0.030 inch between the codebar closest to front of typing unit and its selector blocking lever.

To Adjust

→ Early Design: With clamp nut loosened, use pry point to adjust codebar reset lever. Tighten clamp nut.

→ Late Design (With adjusting screw): Loosen two setscrews and adjust by turning adjusting screw. Tighten setscrews.

Related Adjustments

Affects

PRINT SUPPRESSION LATCH — HORIZONTAL CLEARANCE (2.29);
PRINT SUPPRESSION LATCH — VERTICAL CLEARANCE (2.39);
FUNCTION SHAFT AND CASTING POSITION (2.40); REAR RAIL POSITION (Carriage Area) (2.45);
FOURTH PULSE LINKAGE POSITIONING (Carriage Area) (2.47);
PRINT SUPPRESSION LATCH-LEVER RELEASE (Carriage Area) (2.57);
SPACE SUPPRESSION LEVER CLEARANCE — PRINTING (Spacing Area) (2.65);

Affected By

ROCKER SHAFT POSITION AND END-PLAY (2.26);
CODEBAR RESET LEVER LINE-UP (2.27)

CODEBAR RESET BAIL SPRING

To Check

Set up NUL, an all spacing code combination, in the selector and rotate main shaft until codebar reset bail is in highest position.

Requirement

Min 5-3/4 oz---Max 8-3/4 oz to start codebar reset bail moving.

CODEBAR RESET
BAIL SPRING

CODEBAR
RESET BAIL

(Left Front View)

2.29 Function Area (continued)

PRINT SUPPRESSION LATCH — HORIZONTAL CLEARANCE

(1) Requirement

With typing unit in the stop condition
Min 0.010 inch---Max 0.025 inch
between print suppression latch and
print suppression codebar.

(2) Requirement

Print suppression cam follower and
latch should move freely.

To Adjust

Loosen clamp nut(s) and setscrews in
collars (see Note 1 and Note 2). Position
latch bracket using pry point to meet
Requirement (1). Tighten clamp nuts.
Position collars to meet Requirement
(2). Tighten setscrews.

Related Adjustments

Affects

FUNCTION SHAFT AND CASTING POSITION (2. 40)

Affected By

ROCKER SHAFT POSITION AND ENDPLAY (2. 26)

CODEBAR RESET LEVER POSITION (2. 28)

Note 1: Disregard Requirement (2)
for typing units which are not equipped
with TP180744 collars.

Note 2: Some typing units have one
clamp nut to loosen, others two,
depending upon the configuration of
the latch bracket used.

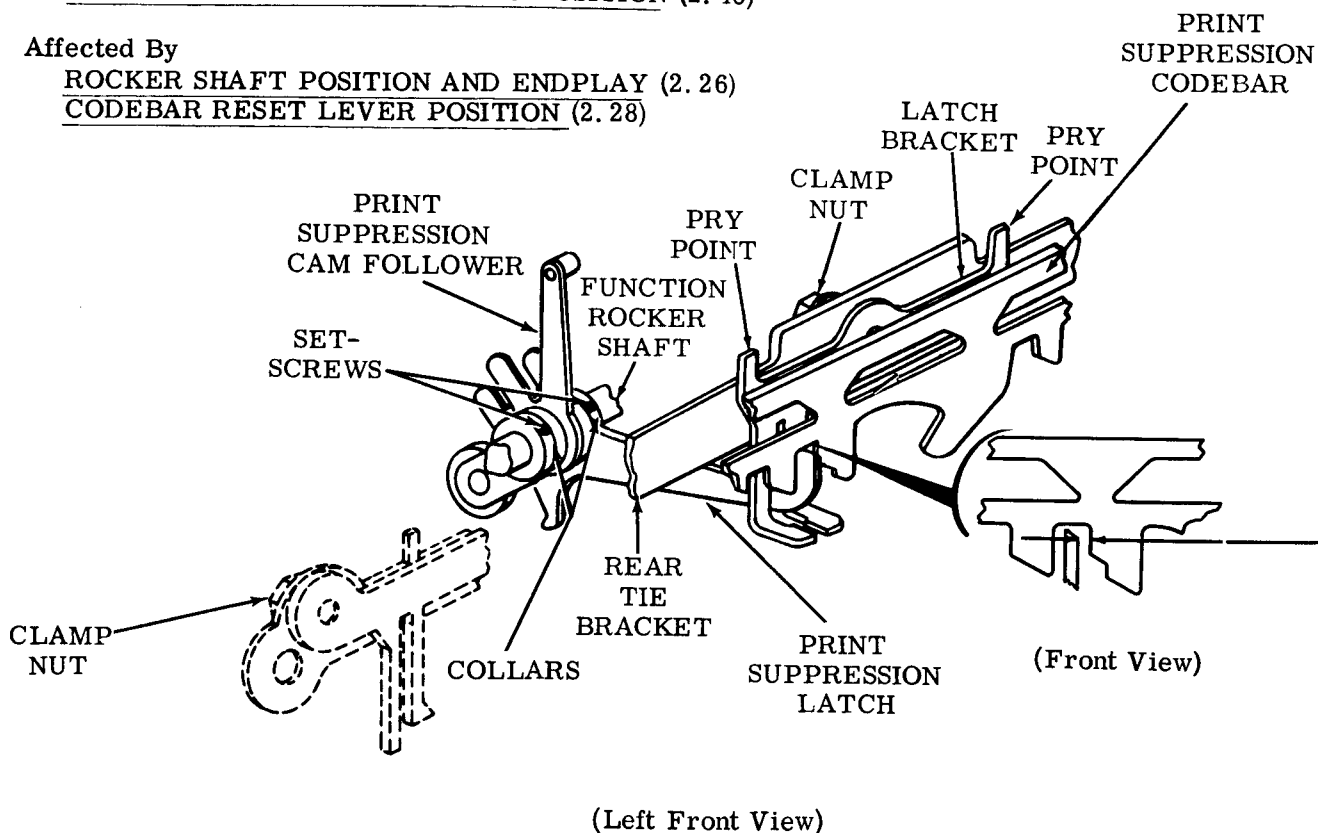

2.30 Function Area (continued)

CODEBAR RESET GUIDE POSITION

(1) Requirement

Codebars should have no noticeable curvature when viewed from their ends.

Note: The following To Check is for units equipped with TP181574 $\overline{\text{EOT}}$ function lever, TP180801 universal function lever, or similar function levers.

To Check

Manually set up RUBOUT, an all marking code combination, in the selector. Rotate main shaft until the function lever reaches its highest point of travel. Lightly take up any play between the function lever and codebars.

(2) Requirement

The codebars should fully engage the function lever tines.

To Adjust

Loosen clampscrew and position codebar guide using pry point. Tighten clampscrew.

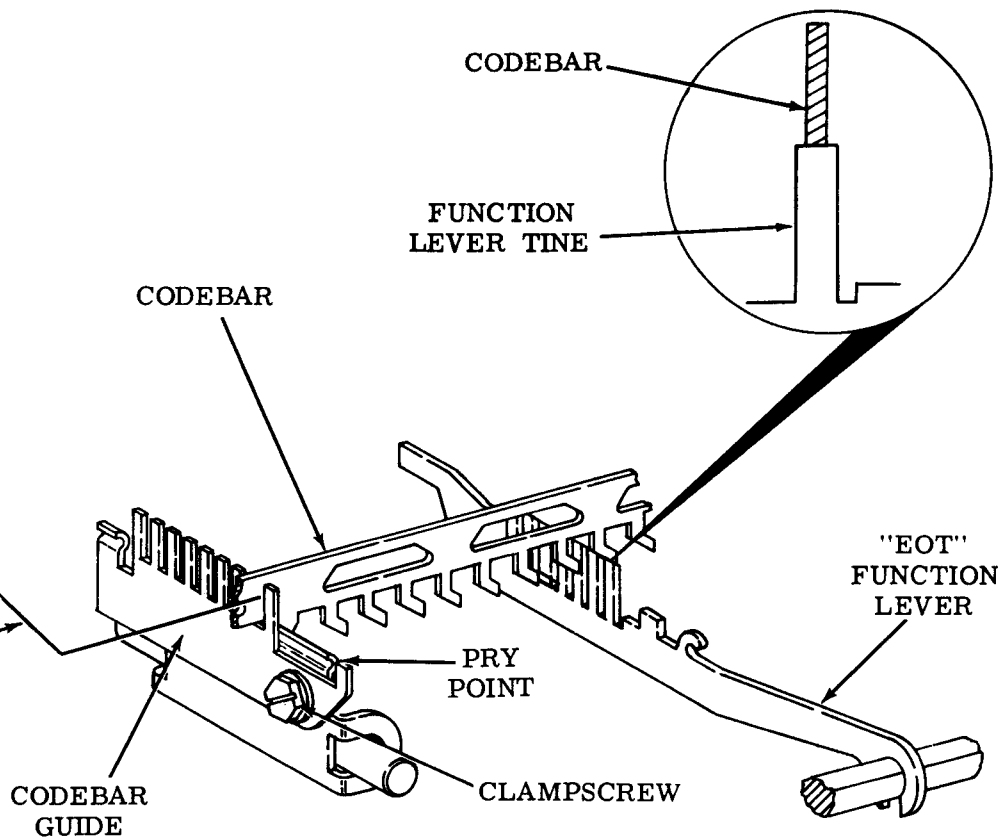

(Left Front View)

2.31 Function Area (continued)

SELECTOR BLOCKING LEVERS POSITIONING

Note: Set range finder to 80 on scale for both (1) and (2) To Check.

(1) To Check

Manually operate typing unit and set up RUBOUT, an all marking code combination in selector. Continue rotating main shaft until selector levers are on peak of their respective cams and codebar ends are approximately flush with left edge of their associated blocking levers.

(1) Requirement

Min 0.006 inch---Max 0.050 inch
between the no. 1 blocking lever and its associated codebar.

(2) Requirement

Min 0.003 inch
between all remaining blocking levers and their associated codebars.

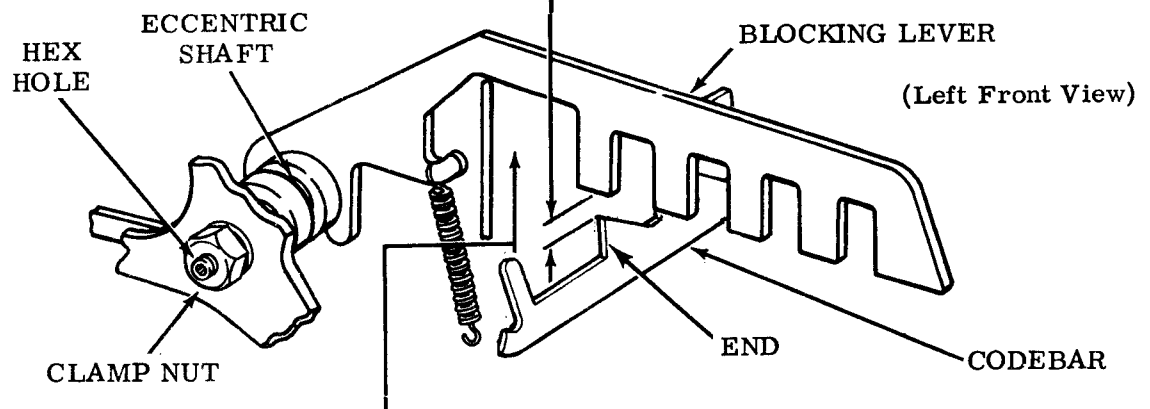

(2) To Check

Manually rotate main shaft. Hold armature forward in its marking position and rotate main shaft until selector clutch shoe lever is in vertical (12 o'clock) position. Continue rotating main shaft until shoe lever reaches 3 o'clock position as viewed from left, and note any vertical motion of no. 1 or no. 2 blocking levers.

Requirement

No visible vertical motion of no. 1 or no. 2 blocking levers while selector clutch shoe lever is moving from 12 o'clock to 3 o'clock position.

To Adjust

Loosen clamp nut and position eccentric with hex key wrench. Keep high part of eccentric toward rear of typing unit. Tighten clamp nut.

Related Adjustments

Affects

CODEBAR GUIDE POSITION (2. 32)

BLOCKING LEVER SPRINGS

To Check

Set up NUL, an all spacing code combination, in the selector. Rotate main shaft until typing unit is in stop condition.

Requirement

Min 1/2 oz---Max 1-1/4 oz
to start blocking lever moving.

Note: Check each blocking lever spring.

2.32 Function Area (continued)

CODEBAR GUIDE POSITION

To Check

Place typing unit in stop condition and manually operate the typing unit until the no. 1 blocking lever is in its lowest position.

(1) Requirement

No. 1 codebar centrally located in guide slot, as gauged by eye.

(2) Requirement

No. 1 blocking lever should engage the full thickness of no. 1 codebar.

To Adjust

Loosen clampscrew. Position codebar guide. Tighten clampscrew.

Related Adjustments

Affected By

SELECTOR BLOCKING LEVERS POSITIONING (2.31)

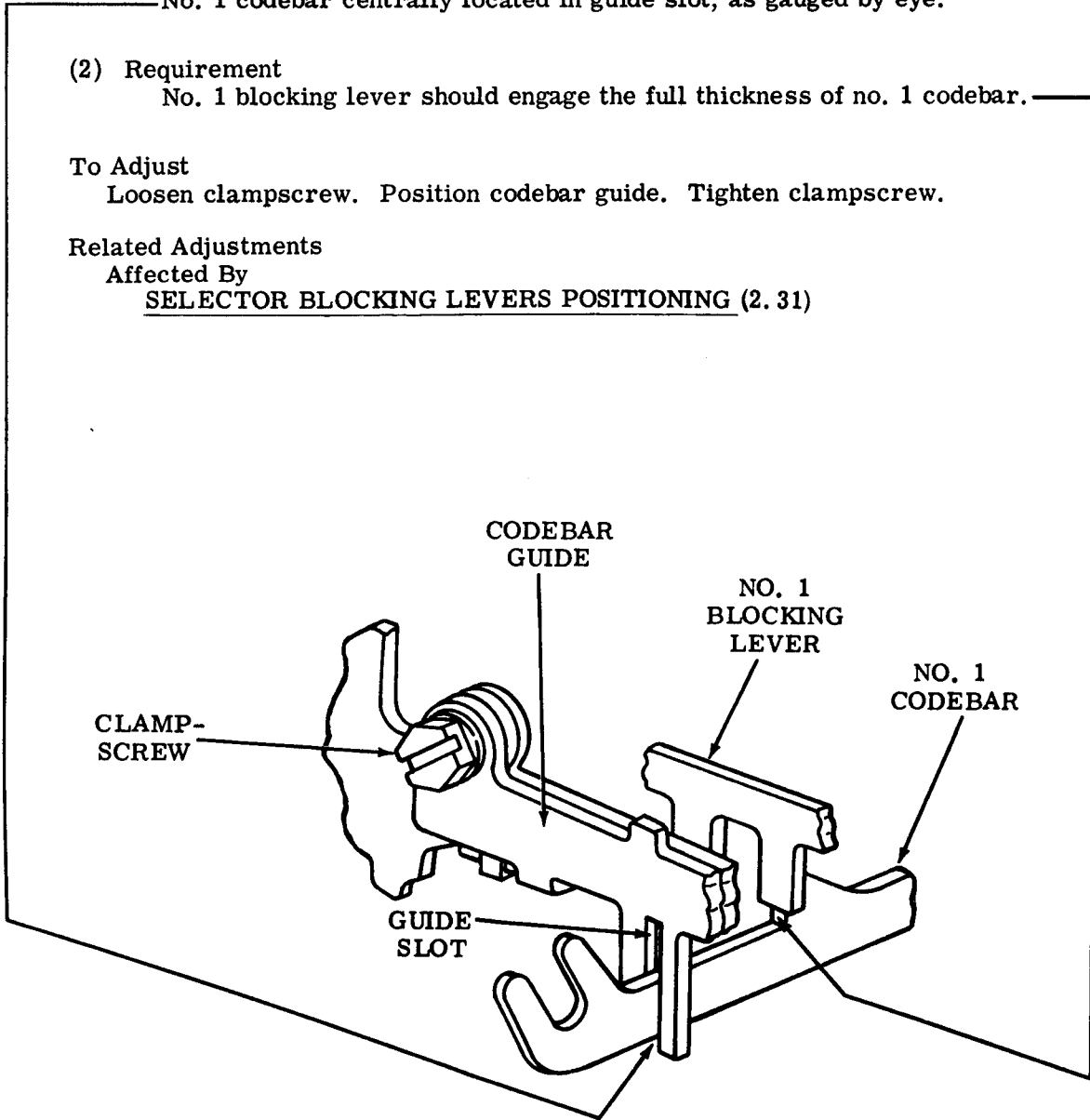

(Left Front View)

2.33 Function Area (continued)

AUTOMATIC CODEBAR SPRING

Requirement

With carriage at left margin TP180948
automatic codebar

Min 1/2 oz---Max 1-3/4 oz _____
TP183495, TP183496, TP183497 automatic
codebars

Min 2 oz---Max 3 oz _____
to start automatic codebar moving.

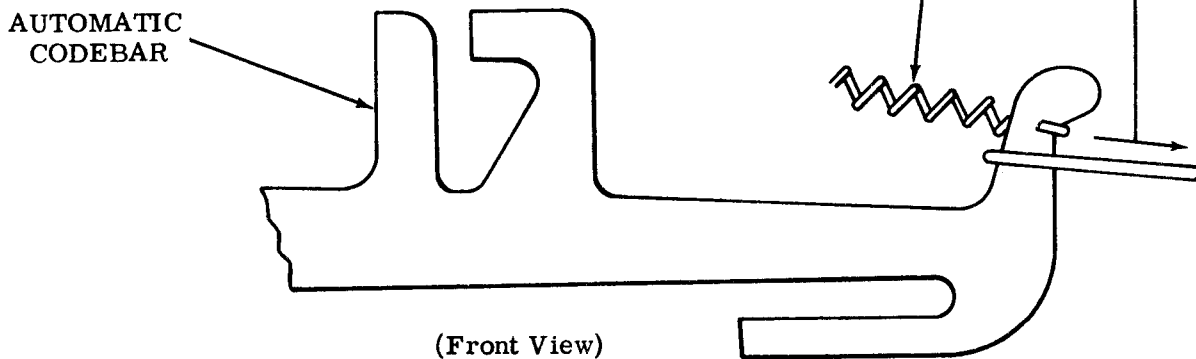

(Front View)

PRINT SUPPRESSION AND NO. 4 CODEBAR SPRING

Requirement

With typing unit in stop condition and no. 4
codebar follower on carriage lifted

Min 12 oz---Max 14 oz _____
to start codebar moving.

Note 1: Check the print suppression
and no. 4 codebar spring.

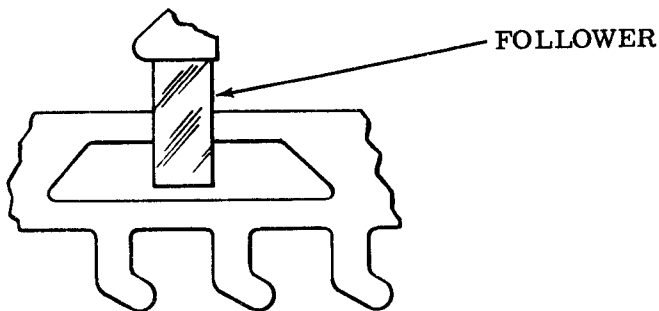

(Front View)

CODEBAR SPRINGS

Note 2: Check each codebar
spring other than automatic,
print suppression and no. 4.

Requirement

With typing unit in stop condition
and codebar follower lifted

Min 5-1/2 oz---Max 7-1/2 oz _____
to start codebar moving.

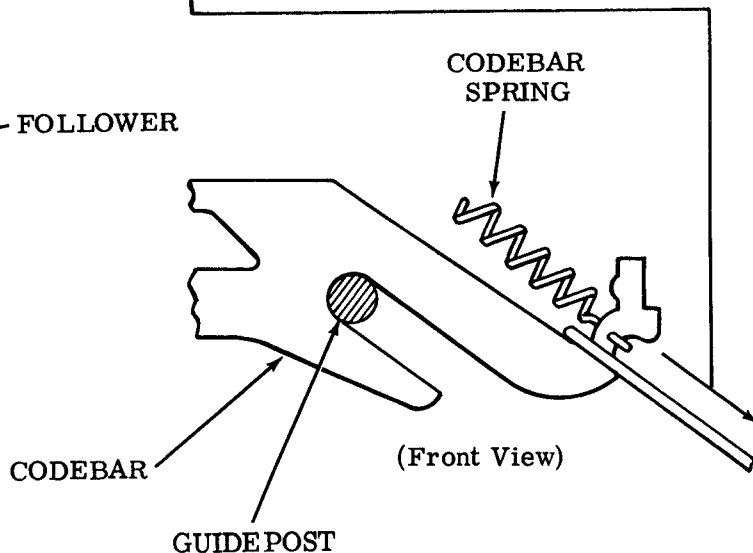

(Front View)

2.34 Function Area (continued)

FUNCTION PAWL SPRING

Requirement

With typing unit in stop condition and all external loads which would influence the requirement removed

Pawl Spring	TP49420 (26 Turns)	TP86283 (38 Turns)	TP180863 (33 Turns)
-------------	-----------------------	-----------------------	------------------------

Min	9 oz	1-1/4 oz	3 oz
Max	13 oz	2-1/2 oz	5-1/2 oz

to start each function pawl moving.

Note: Check each pawl spring. TP180863 pawl spring is used with the carriage return function pawl. TP86283 pawl spring is used with the answer-back blocking function pawl. TP49420 pawl spring is used with BELL and EOT function pawls. All others may be either the TP49420 or TP86283 pawl springs.

LEFT ROCKER DRIVE

To Check

Set up carriage return code combination (1-34---8) in selector. Rotate main shaft until function bail is at highest point of travel. Take up carriage return function lever play in an upward direction at the pivot to minimum clearance.

Requirement

Min 0.015 inch---Max 0.050 inch between carriage return function lever and its function pawl.

To Adjust

Loosen clampscrew. Use pry point to adjust rocker drive arm. Tighten clampscrew.

Note: On early design units pry point is on the center drive arm. On late design units pry point is on left side of left drive arm.

Related Adjustments

Affects

- RIGHT ROCKER DRIVE (2.36)
 - CARRIAGE RETURN LEVER — LATCH CLEARANCE (2.41)
 - FUNCTION LEVER RETAINER (2.37)
 - SPACE SUPPRESSION LEVER CLEARANCE - SPACING (2.66)
 - LINE FEED DRIVE ARM CLEARANCE - F (Platen Area) (2.80)
- Related Tape Punch Adjustments
(Refer to Section 574-125-700TC)

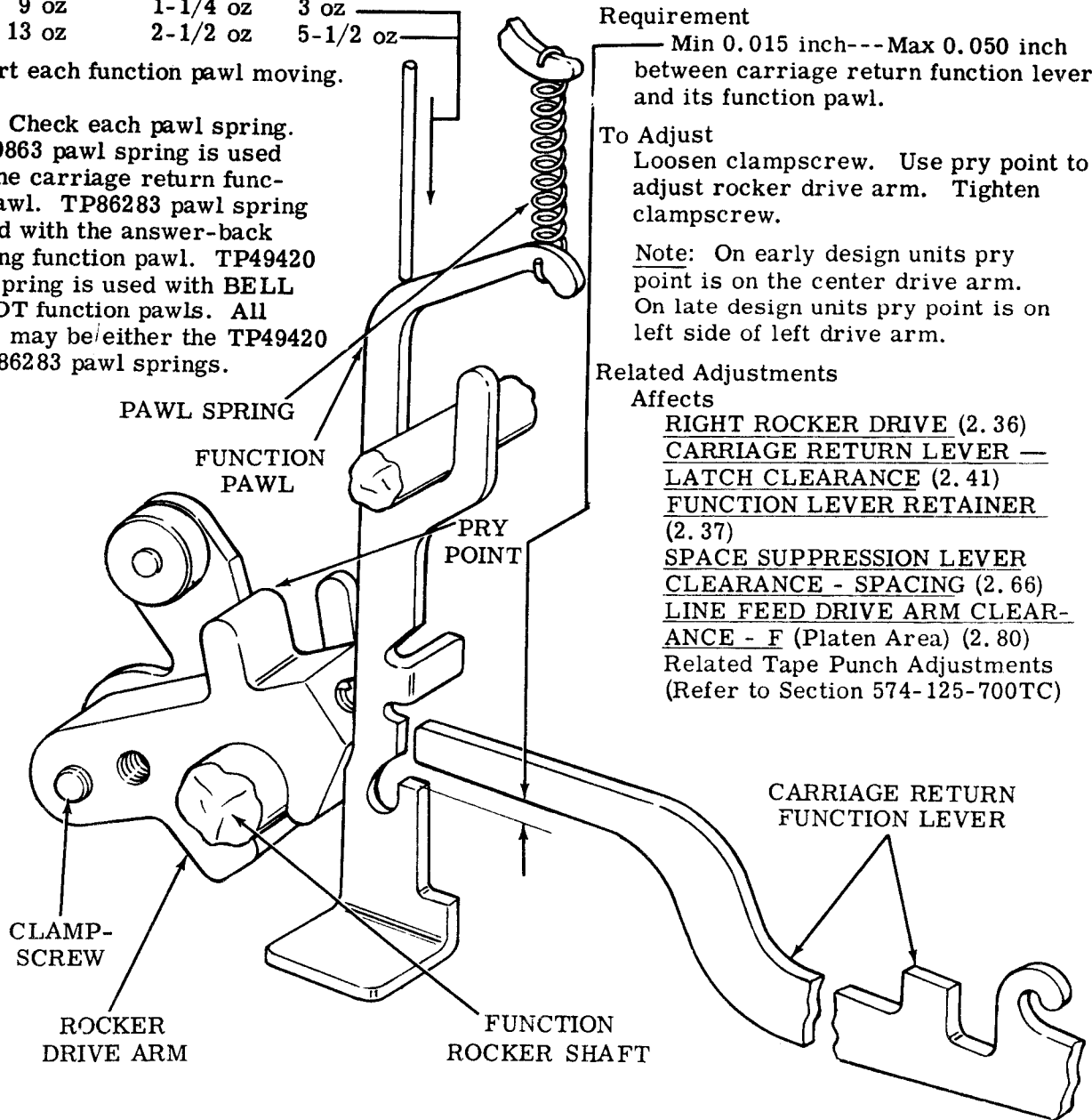

(Left Front View)

2.35 Function Area (continued)

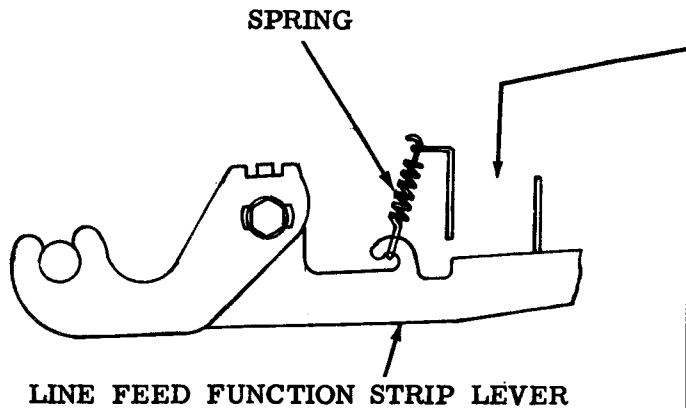

(Right Side View)

LINE FEED FUNCTION STRIP LEVER SPRING - S

Requirement

With a spring scale positioned on the line feed function strip lever

Min 23 oz---Max 30 oz _____
to start the line feed function strip lever moving.

FUNCTION LEVER SPRINGS

Requirement

With typing unit in stop condition, the spring scale requirements to start each function lever moving are

- (1) Min 19 oz---Max 24 oz to start LF and AUTO LF function levers moving.

Note 1: Hold the blocking pawl up when checking this requirement.

- (2) Min 3-1/2 oz---Max 5-1/2 oz to start carriage return function lever moving.

Note 2: Hold carriage return lever in frontward position.

- (3) Min 3-1/2 oz---Max 5-1/2 oz to start remaining function levers moving.

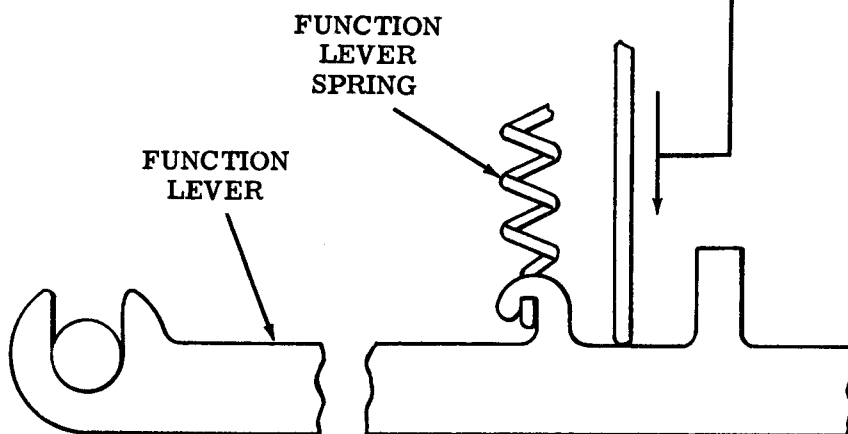

(Right Side View)

2.36 Function Area (continued)

RIGHT ROCKER DRIVE

To Check

Disengage (latch) distributor clutch. Set up answer-back character ENQ code combination (1-3-----) in selector. Rotate main shaft until function bail is at its highest point. Make sure that distributor clutch has not been tripped. Take up answer-back function lever play in an upward direction at the pivot to minimize clearance.

Requirement

Min 0.015 inch---Max 0.050 inch
between answer-back function lever and its function pawl.

To Adjust

Loosen clampscrew. Use pry point to adjust right rocker arm. Tighten clampscrew.

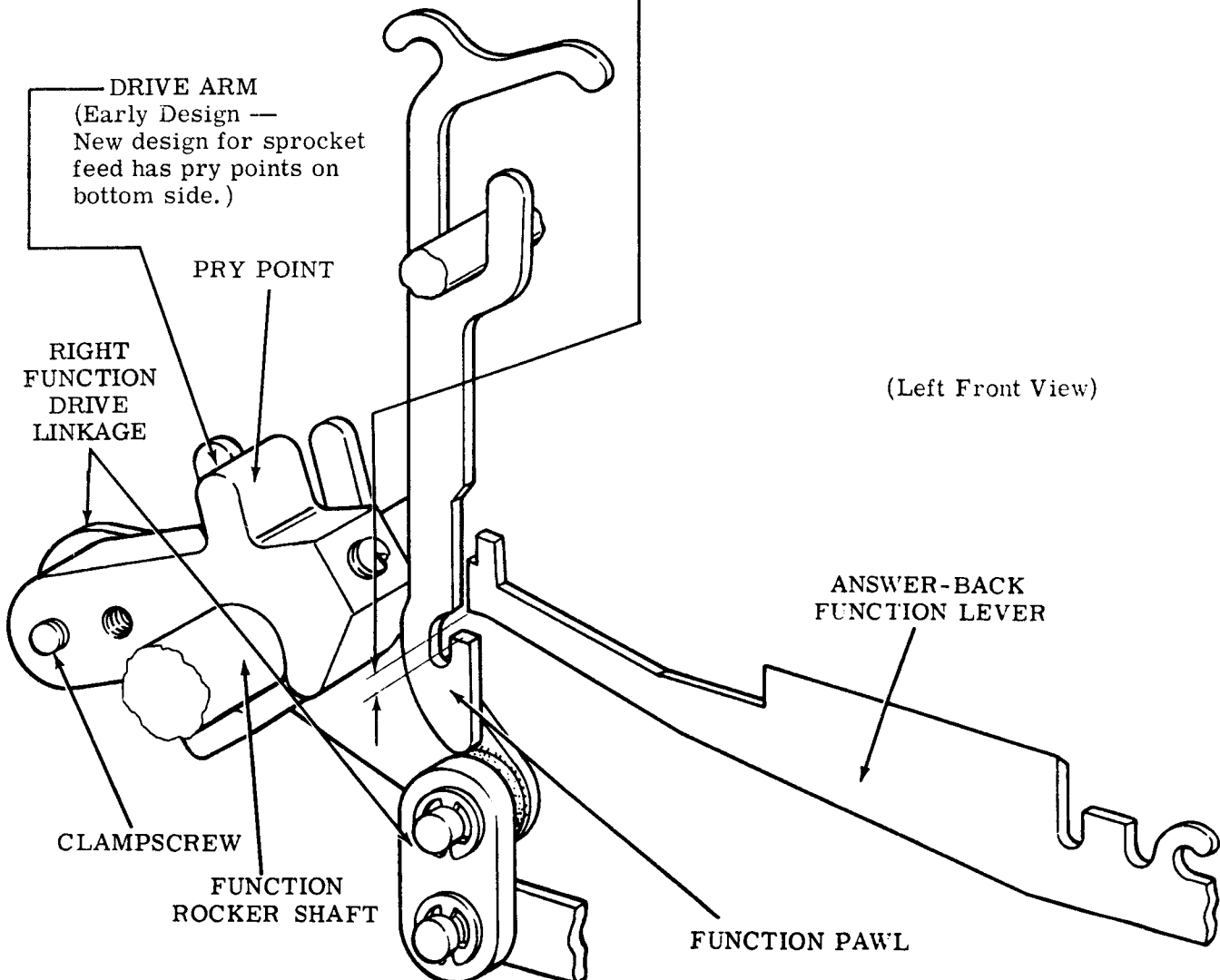

Related Adjustments

Affects

FORM-OUT LEVER OVERTRAVEL - S

(Form Feed Area (2.98)

LINE FEED PAWL STRIPPING - S

(Form Feed Area) (2.107)

TRIPBAIL POSITIONING (3.08)

Affected By

LEFT ROCKER DRIVE (2.34)

Note: If typing unit is not equipped with the answer-back feature, select a code combination which will permit the right-most function lever to be selected.

2.37 Function Area (continued)

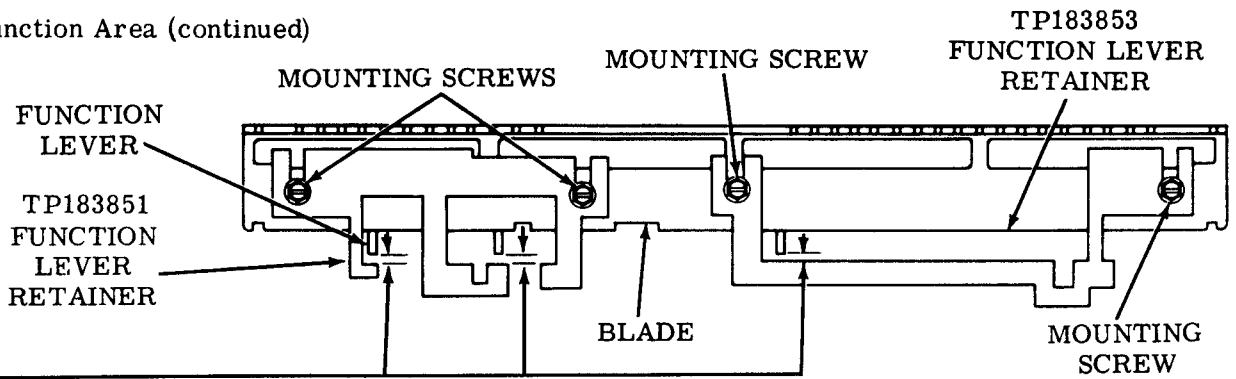

FUNCTION LEVER RETAINER

Units equipped with TP183851 (left and TP183853 (right) function lever retainers.

To Check

With an all marking code combination in the selector, manually operate the typing unit until the blade is at its highest point of travel.

Requirement

Min some---Max 0.040 inch between the function lever retainers and function levers at the closest point.

Note: The lower edges at the mounting portion of the retainer should not extend below the lower edge of the blade.

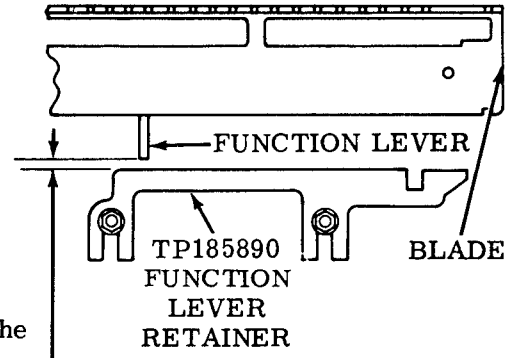

Units equipped with the TP185980 function lever retainers and the print-nonprint feature.

To Check

With an all marking code combination in the selector, manually operate the typing unit until the blade is at the lowest point of travel.

Requirement

Min some---Max 0.020 inch between the retainer and the function lever closest to it.

To Adjust

Loosen mounting screws and position retainers. Tighten screws.

FUNCTION BAIL SPRING

Requirement

With typing unit in stop condition
Min 72 oz---Max 104 oz
to pull each function bail spring to installed length.

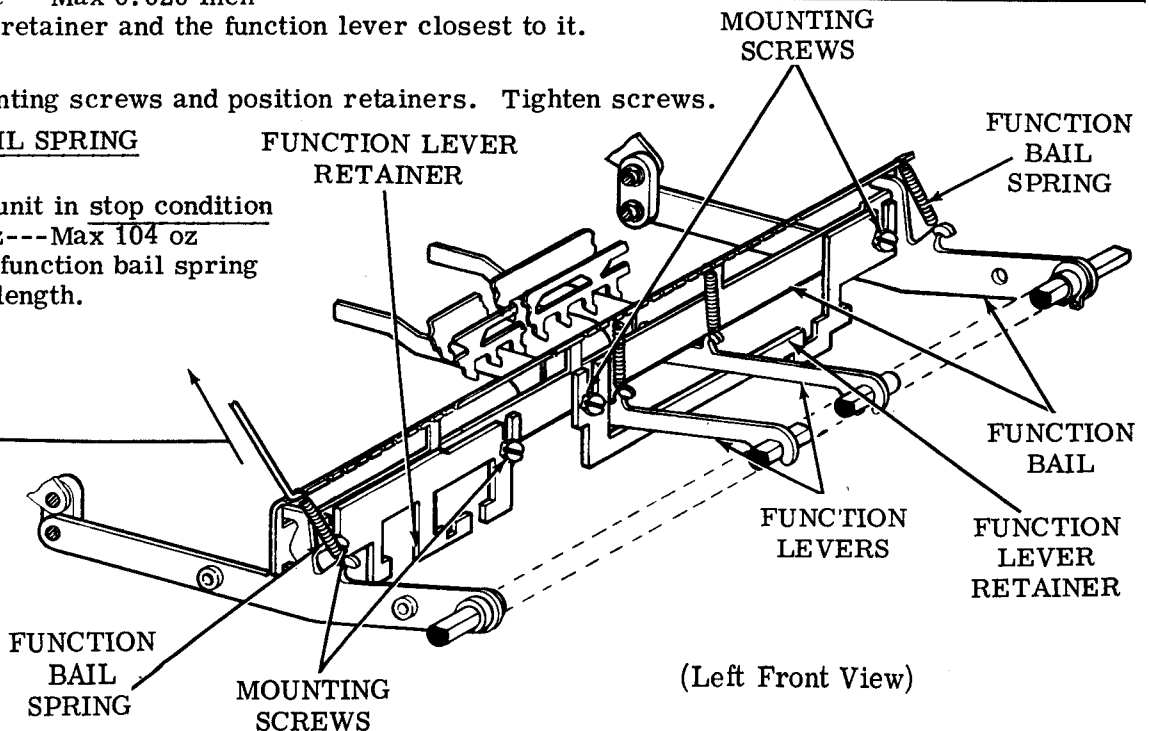

(Left Front View)

2.38 Function Area (continued)

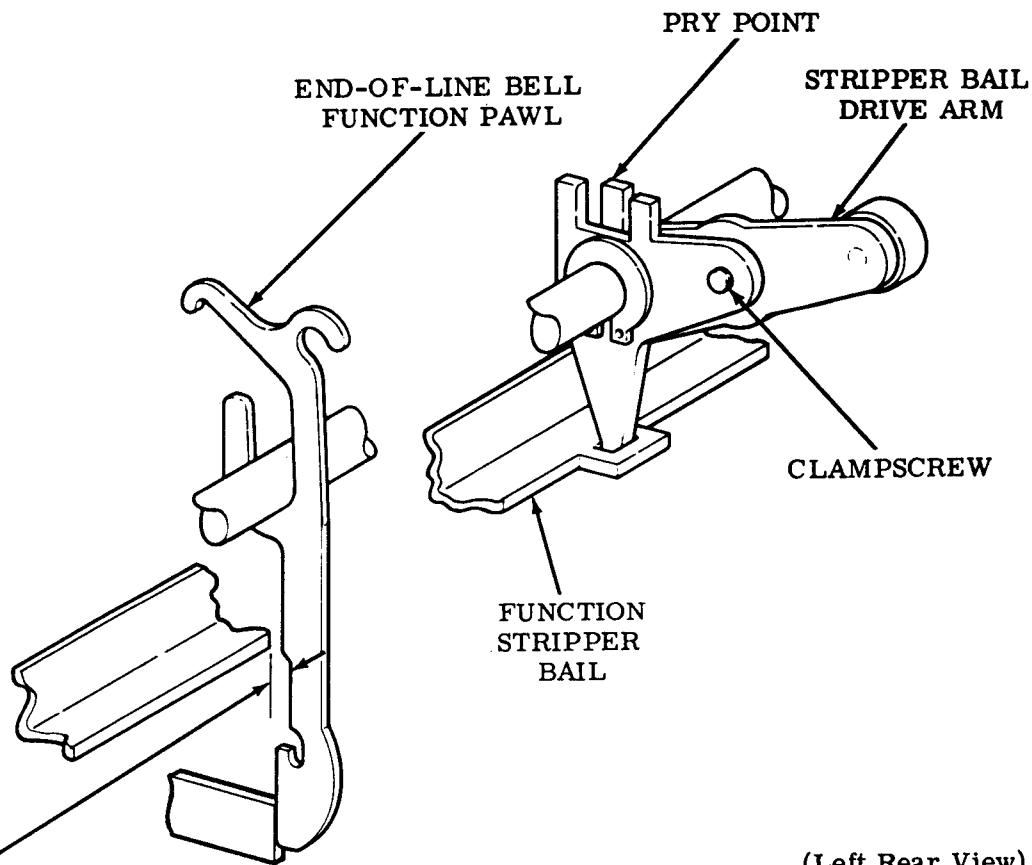

(Left Rear View)

STRIPPER BAIL CLEARANCE

Requirement

With typing unit in stop condition

Min 0.015 inch---Max 0.025 inch

between function stripper bail and edge of stripped end-of-line bell function.

Note: For typing units which are not equipped with the end-of-line bell function pawl, check requirement at the TP180792 function pawl closest to slot F in function casting.

To Adjust

Loosen clampscrew. Use pry point to position stripper bail drive arm. Tighten clampscrew.

Related Adjustment

Affects

LINE FEED STRIPPER PLATE CLEARANCE - F (Platen Area) (2.85)

2.39 Function Area (continued)

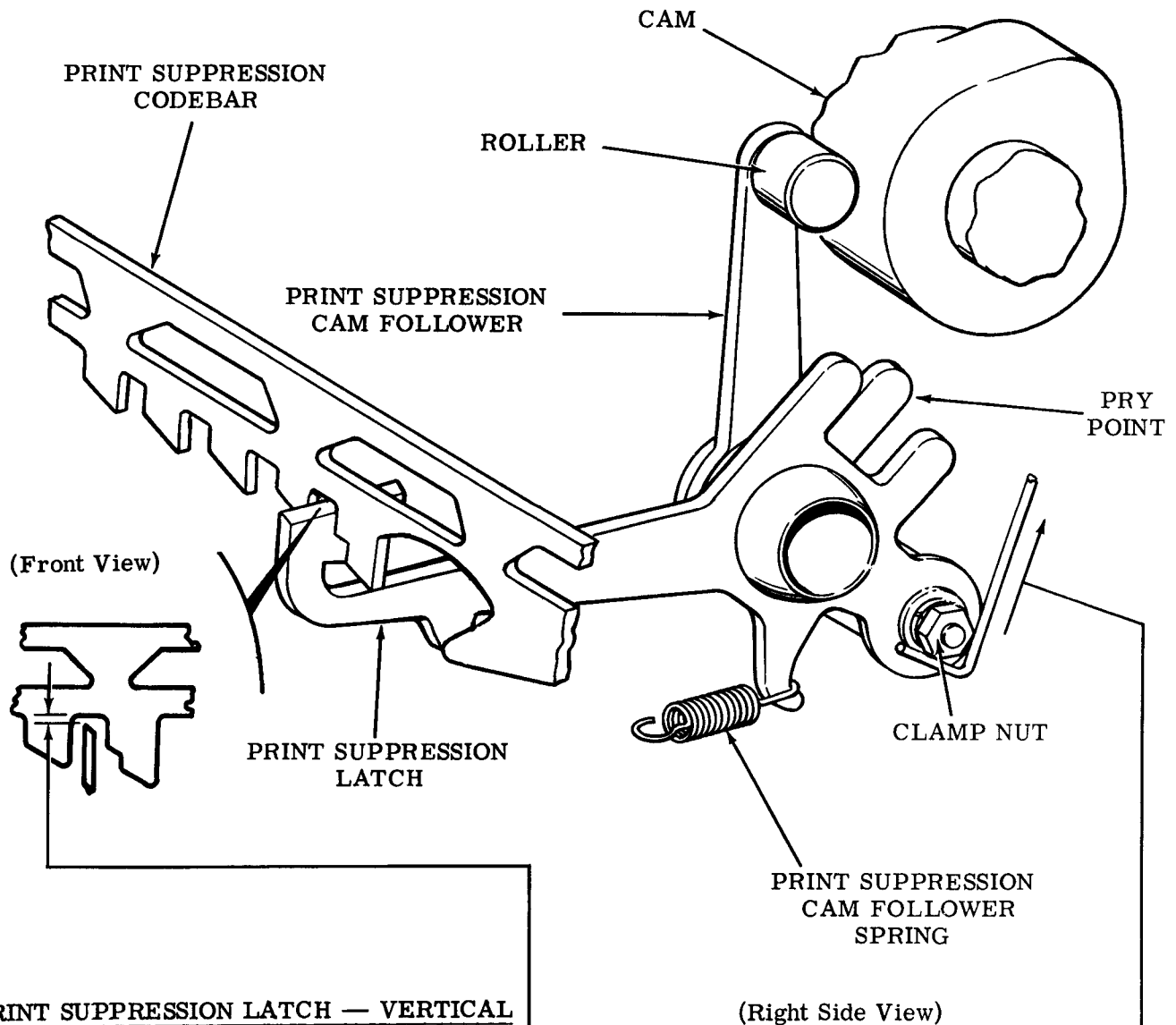

PRINT SUPPRESSION LATCH — VERTICAL CLEARANCE

Requirement

With typing unit in stop condition and print suppression cam follower roller resting on its cam

Min 0.015 inch---Max 0.050 inch
between print suppression latch and print suppression codebar.

To Adjust

Loosen clamp nut. Using pry point, position print suppression cam follower. Tighten clamp nut.

Related Adjustments

Affected By
CODEBAR RESET LEVER POSITION (2.28)

PRINT SUPPRESSION CAM FOLLOWER SPRING

Requirement

With typing unit in stop condition

Min 10 oz---Max 14 oz
to start print suppression cam follower moving.

2.40 Function Area (continued)

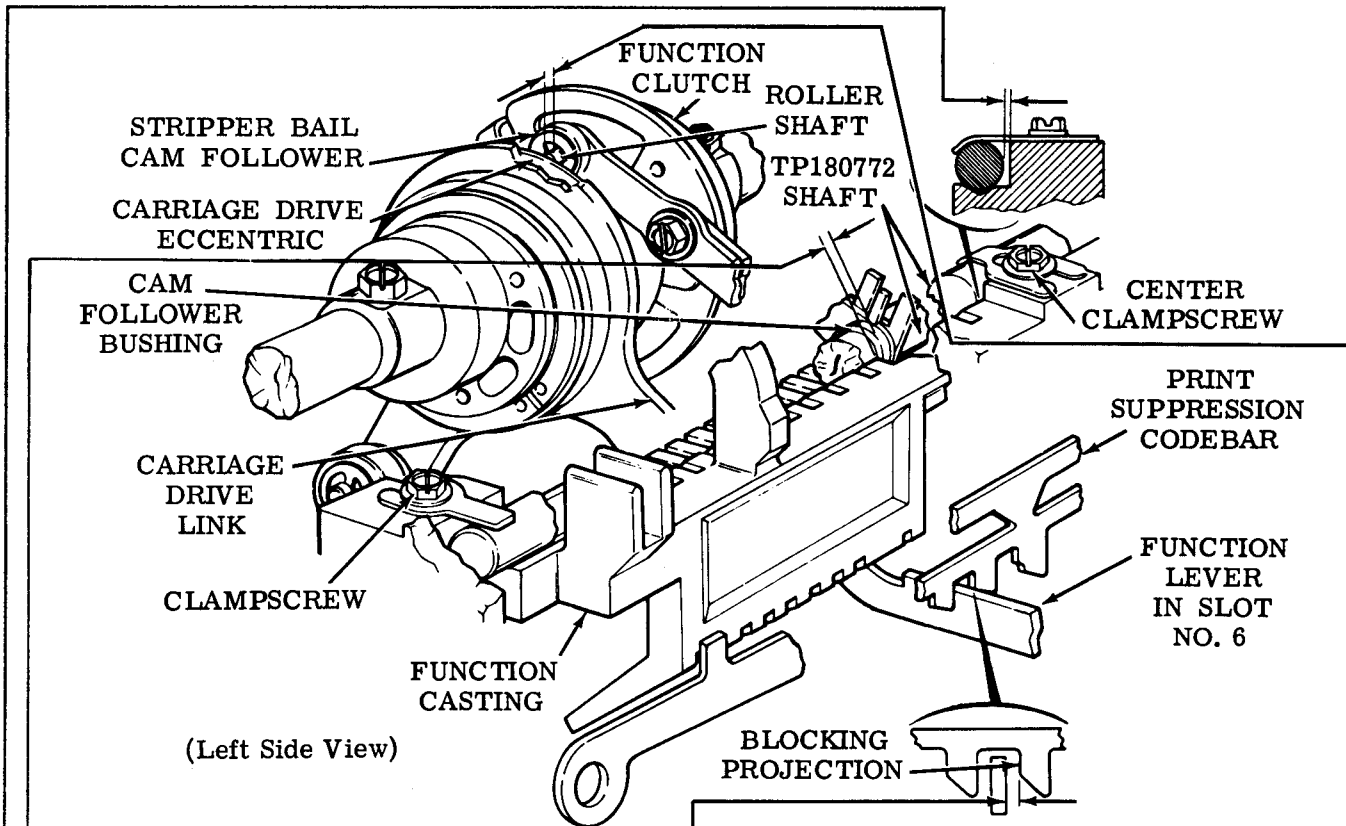
**FUNCTION SHAFT AND CASTING POSITION**

Note: The Requirement (1) applies only to TP180772 shafts which have raised rings which serve to locate the stripper bail cam follower.

(1) Requirement

Min some---Max 0.010 inch between stripper bail cam follower and left side of slot in function casting.

To Adjust

Loosen clampscrews and position TP180772 shaft.

(2) Requirement

The shaft should be in contact with, or not more than
 Max 0.003 inch
 away from the vertical surface at the center of the function casting.

To Adjust

With the center and two end clampscrews loosened, position to meet Requirements (1) and (2).

To Check

Manually set up NUL, an all spacing code combination in selector. Rotate main shaft until suppression cam follower just begins to rise on its cam.

(3) Requirement

Min 0.030 inch---Max 0.050 inch between blocking projection on print suppression codebar and the function lever in slot no. 6.

(4) Requirement

Min 0.005 inch
 between carriage drive eccentric and roller shaft on stripper bail cam follower with play taken up to make clearance a minimum.

To Adjust

With the two end clampscrews loosened, position casting to meet Requirements (3) and (4). Tighten clampscrews.

Related Adjustments**Affected By**

CODEBAR RESET LEVER POSITION
 (2.28)
PRINT SUPPRESSION LATCH —
HORIZONTAL CLEARANCE (2.29)
LEFT BEARING POSITION (2.10)

2.41 Function Area (continued)

CARRIAGE RETURN LEVER – LATCH CLEARANCE

To Check

Position carriage to center of typing unit and carefully remove carriage return spring. Set up carriage return code combination (1-34---8) in selector. Rotate main shaft until function bail reaches lowest point of travel. Position left end of carriage return lever rearward to eliminate its play.

- (1) Requirement
 Early design
 carriage return lever flush with
 carriage return latch
 Within 0.005 inch

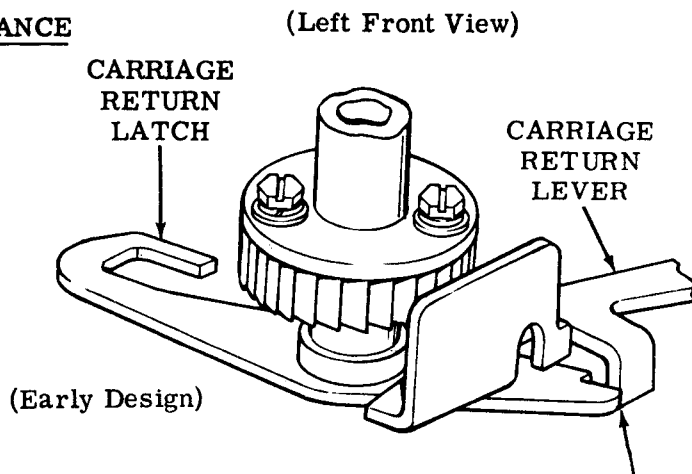

- (2) Requirement
 Late design
 Min some---Max 0.030 inch
 between carriage return lever and
 carriage return latch.

To Adjust

Loosen clampscrew. Use pry points to position carriage return lever. Tighten clampscrew. Replace carriage return spring.

Related Adjustment

Affected By
LEFT ROCKER DRIVE (2.34)

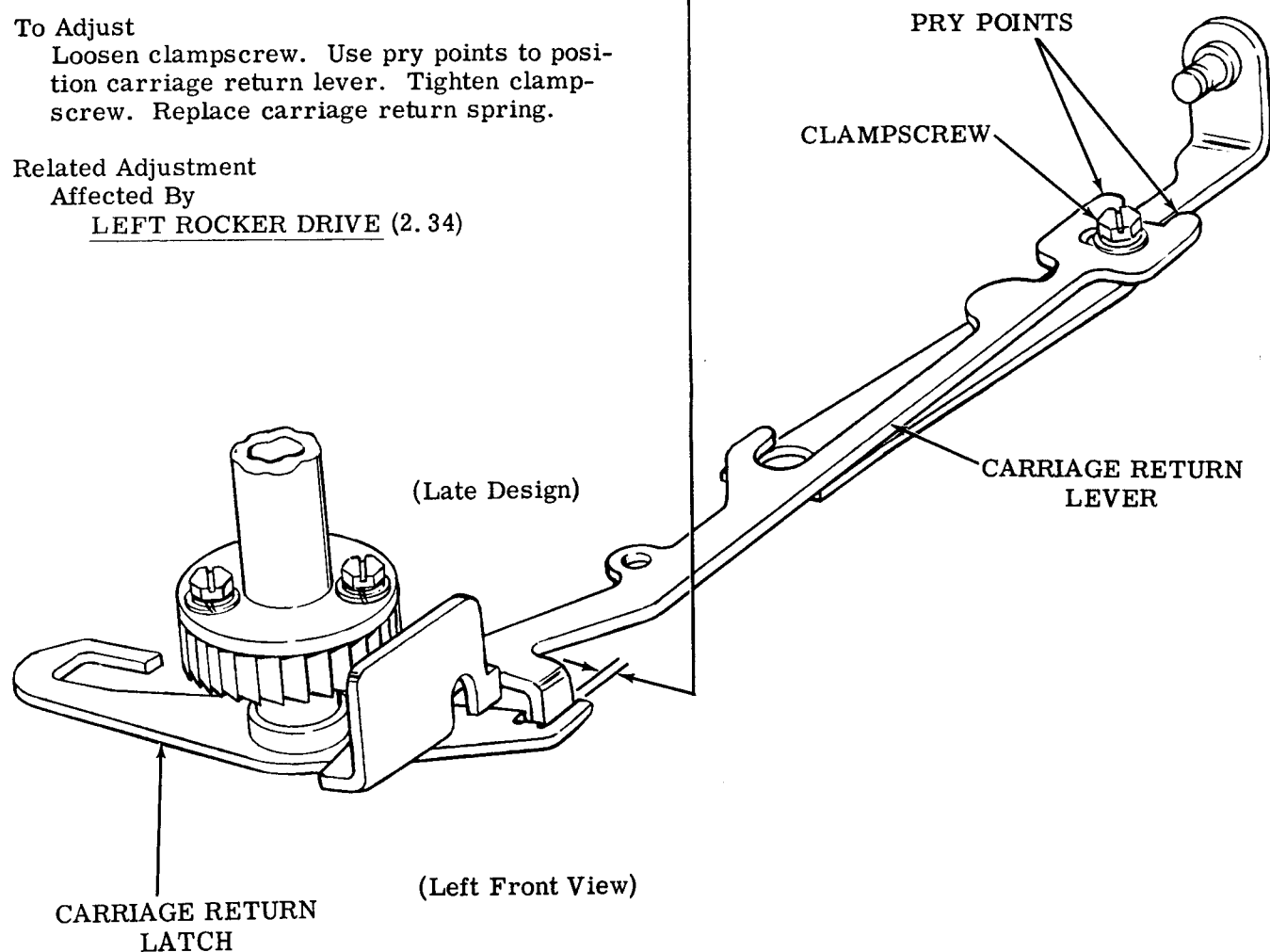

2. 42 Function Area (continued)

CARRIAGE DRIVE BAIL ENDPLAY

To Check

Rotate main shaft until carriage drive bail is parallel to the base casting.

Requirement

Min some---Max 0.015 inch endplay in carriage drive bail.

To Adjust

Loosen clampscrew and position carriage drive bail left pivot. Tighten clampscrew.

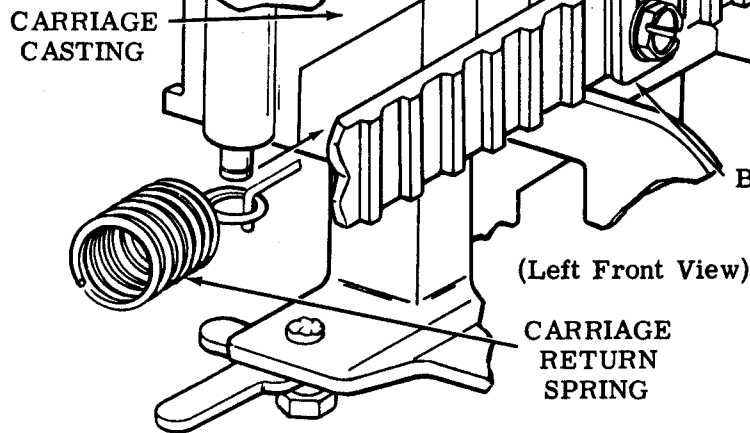
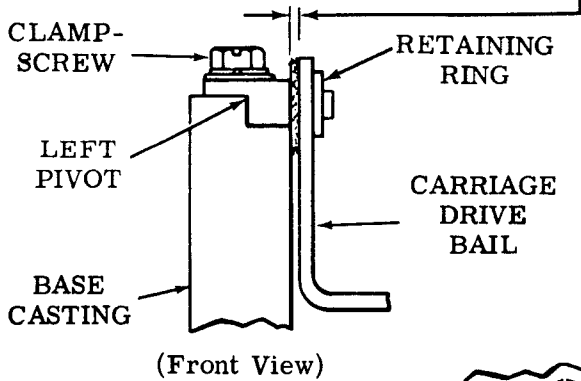

CARRIAGE RETURN SPRING

Requirement

With typing unit in stop condition and carriage at right margin

Min 56 oz---Max 64 oz to pull carriage return spring to installed length.

BELL CLAPPER GAP

(1) Requirement

With typing unit in stop condition
Min 0.030 inch---Max 0.070 inch between clapper and bell.

To Adjust

Using pliers, bend clapper spring.

(2) Requirement

The bell must be audible when operated.

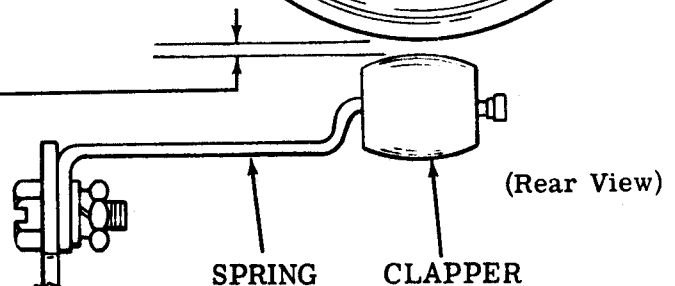

2.43 Carriage Area

FRONT ROLLERS CLEARANCE

Note 1: This adjustment does not apply to typing units equipped with nonadjustable parts such as TP183503 bearing housing and TP183504 bearing retainer.

To Check

Place typing unit in stop condition.
Remove the carriage return spring.
Take up roller play toward the front of the typing unit.

Requirement

Min some---Max 0.005 inch
between carriage front roller and
carriage front rail.

To Adjust

Loosen mounting nut and position
each roller against rail by means
of eccentric shaft. Slowly back off
eccentric shaft to meet requirement.
Tighten mounting nut.

Note 2: Some positions of carriage front
roller may show a slight drag condition.
This is acceptable providing there is no
perceptible increase in carriage friction
due to condition.

Related Adjustments**Affects**

PRINT DRIVE LEVER POSITIONING (2.48)
PRINT SUPPRESSION LATCHLEVER RELEASE (2.57)
RIBBON POWER LEVER DRIVE (2.62)
PLATEN HORIZONTAL POSITION - F (2.70)
PLATEN HORIZONTAL POSITION - S (2.89)

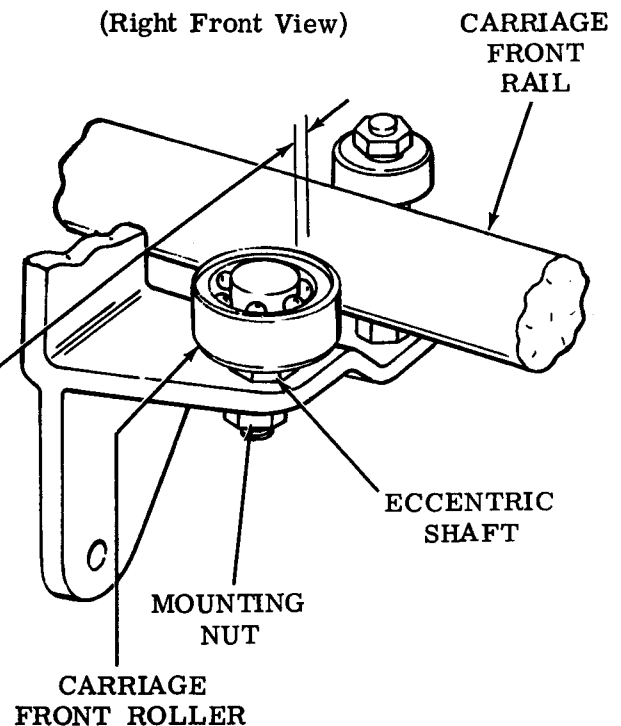

2.44 Carriage Area (continued)

POWER BAIL ROLLER CLEARANCE

To Check

Trip function clutch and rotate main shaft until carriage drive bail is at lowest point of travel.

Requirement

Min some---Max 0.005 inch between front roller and carriage drive bail.

To Adjust

Loosen mounting nut and position front roller by means of eccentric shaft. Tighten mounting nut.

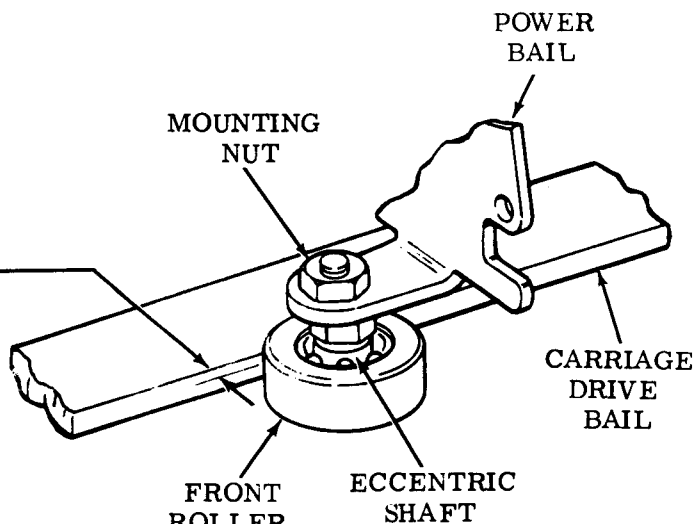

(Left Front View)

RACK AND PINION BACKLASH

Note 1: This adjustment is to be performed only on early design carriages having the TP180548 adjusting plate and TP180549 bracket. Late design carriages do not require this adjustment.

To Check

Place typing unit in stop condition.

Requirement

Each rack should have Min some---Max 0.010 inch backlash.

To Adjust

Loosen lock plate clampscrews and move lock plate towards the rear. Loosen one adjusting plate clampscrew friction tight and place a 0.010-inch feeler gauge between the rack and adjusting plate. Position adjusting plate for no play between the rack and pinion using pry point. Tighten adjusting plate clampscrew and remove feeler gauge. Repeat procedure for adjusting plate on other side. Position lock plate against adjusting plates. Tighten lock plate clampscrews.

Note 2: Do not loosen both adjusting plate clampscrews at the same time.

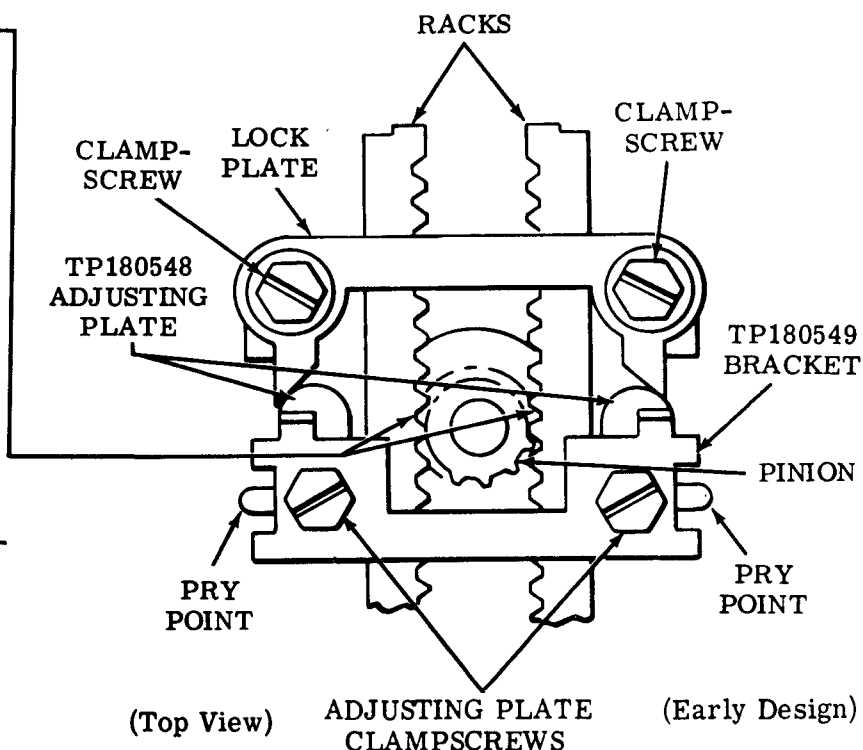
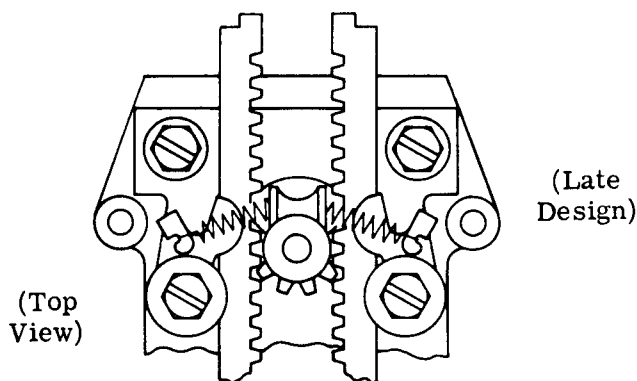

2.45 Carriage Area (continued)

REAR RAIL POSITION

(1) To Check
 Position the dashpot plunger just outside the dashpot cylinder. With the selector no. 1 code level in the marking condition, rotate the main shaft until the shift slide is in its uppermost position and contacts the stop plate. Take up all play to minimize the required clearance.

Requirement
 Min 0.025 inch---Max 0.040 inch
 between bottom edge of shift slide
 and top edge of stop plate.

(2) To Check
 Condition the typing unit as in (1) To Check above except place carriage to the right with center of the typewheel 1/2 inch from the right hand margin.

Requirement
 Min 0.025 inch---Max 0.040 inch
 between bottom edge of shift slide
 and top edge of stop plate.

(3) To Check
 Calculate the difference between the recorded measurements in To Check (1) and To Check (2) above.

Requirement
 Max 0.010 inch
 difference between recorded measurements.

To Adjust
 Loosen two carriage rear rail mounting screws friction tight, and position carriage rear rail using pry point. Tighten mounting screws.

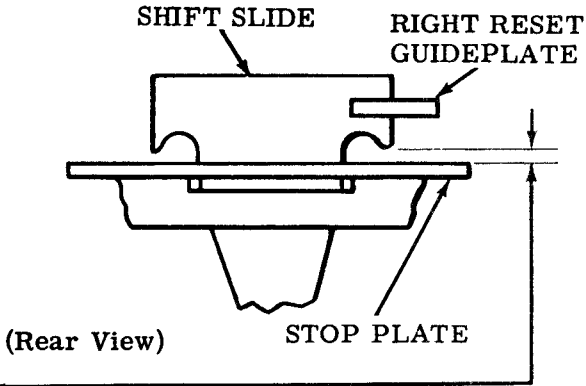

Related Adjustments
 Affects

- PRINT DRIVE LEVER POSITIONING (2.48)
- FOURTH PULSE LINKAGE POSITIONING (2.47)
- RESET LEVER POSITIONING (2.49)
- PRINT SUPPRESSION LATCHLEVER RELEASE (2.57)
- PRESSURE ROLLER CLEARANCE (Platen Area) (2.84)
- REAR ROLLER CLEARANCE (2.46)
- RIGHT SLIDE GUIDEPLATE RESET (2.52)
- LEFT SLIDE GUIDEPLATE RESET (2.53)
- PRINT HAMMER TRIP LEVER RELEASE (2.54)
- PRINT HAMMER TRIP LEVER RESET (2.55)
- RIBBON POWER LEVER DRIVE (2.62)
- VERTICAL TYPE ALIGNMENT - F (2.71)
- VERTICAL TYPE ALIGNMENT - S (2.90)

Affected By
CODEBAR RESET LEVER POSITION (Function Area) (2.28)

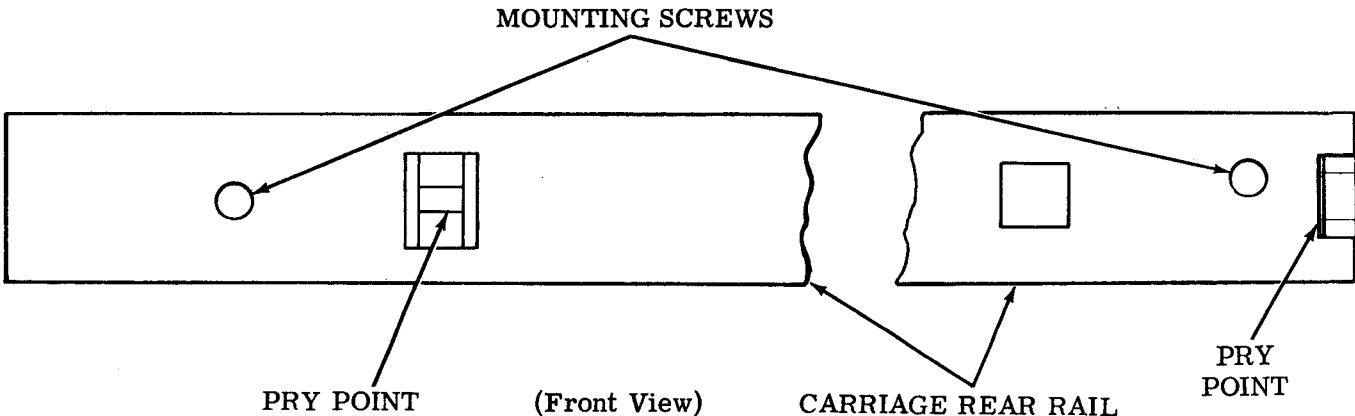

2.46 Carriage Area (continued)

REAR ROLLER CLEARANCE

To Check

Rotate main shaft until carriage drive bail is in rearmost position.

Requirement

Min some---Max 0.008 inch between carriage rear rail and carriage rear roller (upper).

To Adjust

Loosen clamp nut and position eccentric shaft with hex wrench in hex hole. Tighten clamp nut.

Related Adjustments

Affects

FOURTH PULSE LINKAGE POSITIONING
(2.47)

PRINT DRIVE LEVER POSITIONING
(2.48)

RESET LEVER POSITIONING (2.49)

RIGHT SLIDE GUIDEPLATE RESET
(2.52)

PRINT HAMMER TRIP LEVER RELEASE
(2.54)

PRINT HAMMER TRIP LEVER RESET
(2.55)

Affected By

REAR RAIL POSITION (2.45)

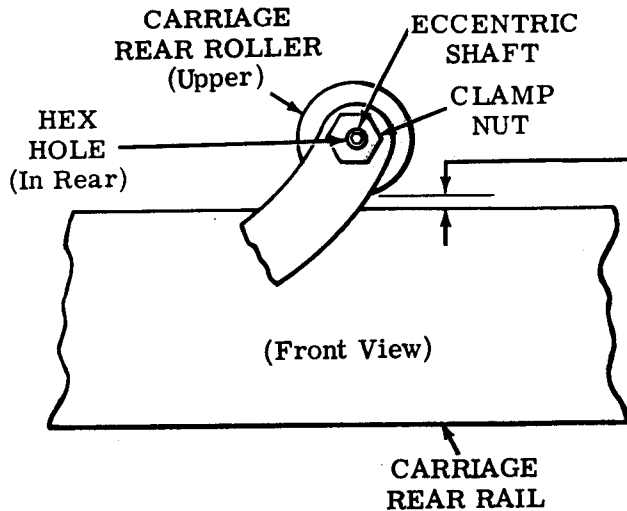

2.47 Carriage Area (continued)

FOURTH PULSE LINKAGE POSITIONING**To Check**

Place carriage to left margin. With an all marking code combination set up in selector, manually operate the typing unit until the function clutch just trips. Take up play in left rack in a downward direction. Check requirement, then repeat requirement check with carriage at the right margin.

Requirement

Min 0.005 inch---Max 0.055 inch
between rotary drive arm and left rack.

To Adjust

Bend pulse lever using pry points.

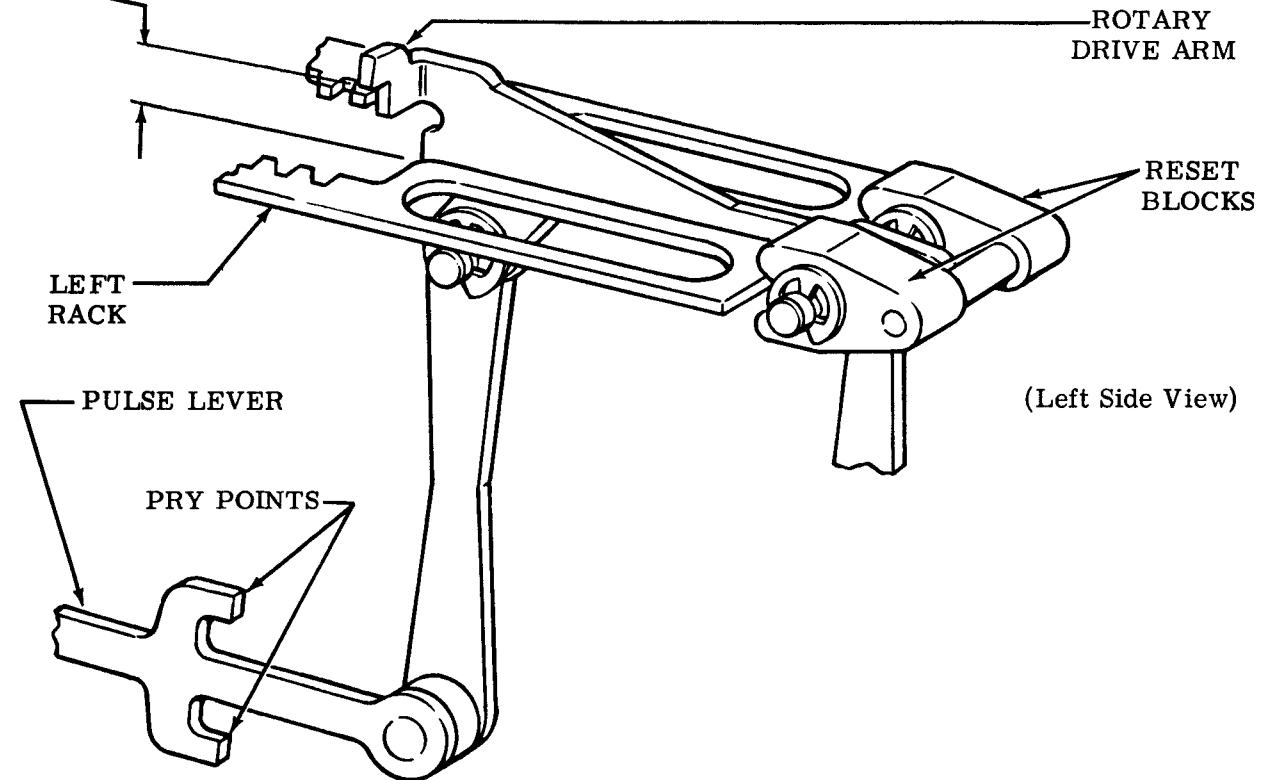
**Related Adjustments****Affected By**

CODEBAR RESET LEVER POSITION (Function Area) (2.28)

REAR RAIL POSITION (2.45)

REAR ROLLER CLEARANCE (2.46)

2.48 Carriage Area (continued)

(B) PRINT DRIVE LEVER POSITIONING**To Check**

Place typing unit in stop condition and move carriage until its power bail rollers are positioned directly above the carriage drive link. Take up play in vertical drive bail in a downward direction, and take up play in common stop arm toward the left.

Requirement

Late design typing units equipped with TP183993 function clutch cam sleeve

Min 0.065 inch---Max 0.090 inch
between vertical drive bail and common stop arm.

Early design typing units equipped with TP180806 function clutch cam sleeve

Min 0.229 inch---Max 0.239 inch
between vertical drive bail and common stop arm as gauged with a TP180588 adjusting tool.

Note: The TP180588 adjusting tool has a nominal dimension of 0.234 inch.

To Adjust

Loosen print drive lever clampscrew and position print drive lever using pry points. Tighten clampscrew.

Related Adjustments**Affects**

RIGHT SLIDE GUIDEPLATE

RESET (2.52)

PRINT HAMMER TRIP LEVER

RESET (2.55)

LEFT SLIDE GUIDEPLATE

RESET (2.53)

RIBBON POSITIONING (2.56)

VERTICAL TYPE ALIGNMENT - F
(2.71)

VERTICAL TYPE ALIGNMENT - S
(2.90)

PRINT SUPPRESSION LATCH-
LEVER ENDPLAY (2.50)

Affected By

REAR RAIL POSITION (2.45)

FRONT ROLLERS CLEARANCE
(2.45)

REAR ROLLER CLEARANCE
(2.46)

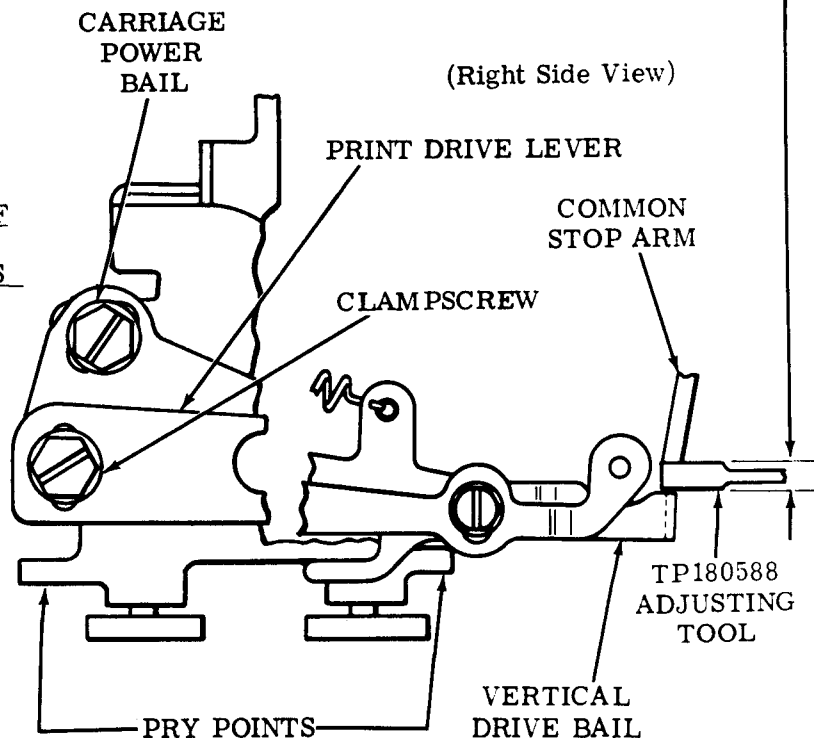

2.49 Carriage Area (continued)

RESET LEVER POSITIONING

Requirement

When typing unit returns to stop condition, racks should be completely reset.

To Adjust

Place carriage in center of typing unit. Loosen clampscrew and allow positioning spring to fully reset racks. Tighten clampscrew.

Related Adjustments

Affects

RIBBON POWER LEVER DRIVE (2.62)

Affected By

REAR RAIL POSITION (2.45)

REAR ROLLER CLEARANCE (2.46)

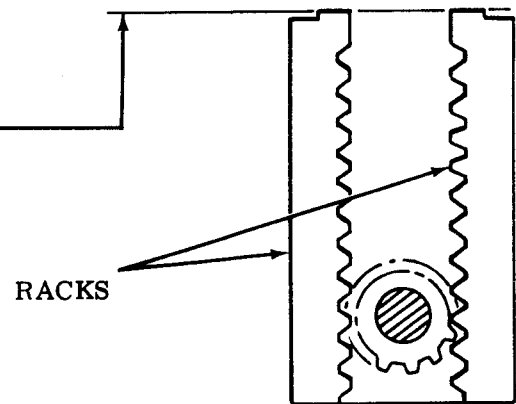

(Top View)

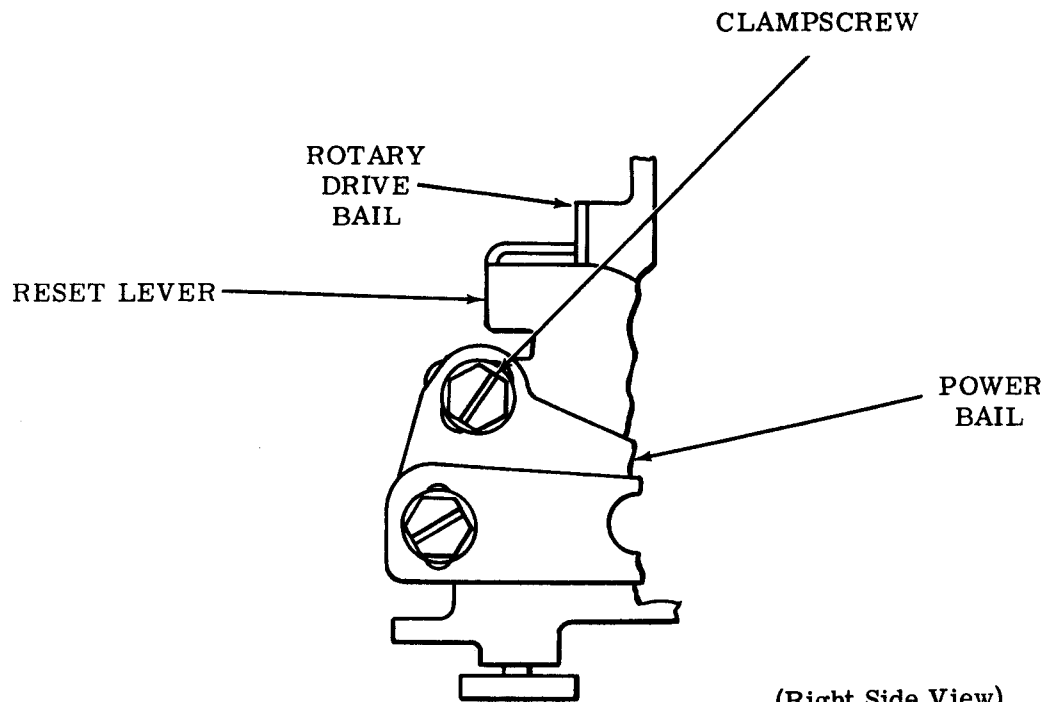

(Right Side View)

2.50 Carriage Area (continued)

PRINT SUPPRESSION LATCHLEVER ENDPLAY

To Check

Take up play in print suppression latchlever towards carriage casting.

Requirement

Print suppression latchlever should fully engage print hammer bail with no binds.

To Adjust

Loosen setscrew with hex key wrench and position collar. Tighten setscrew.

Related Adjustments

Affected By

PRINT DRIVE LEVER POSITIONING (2.48)

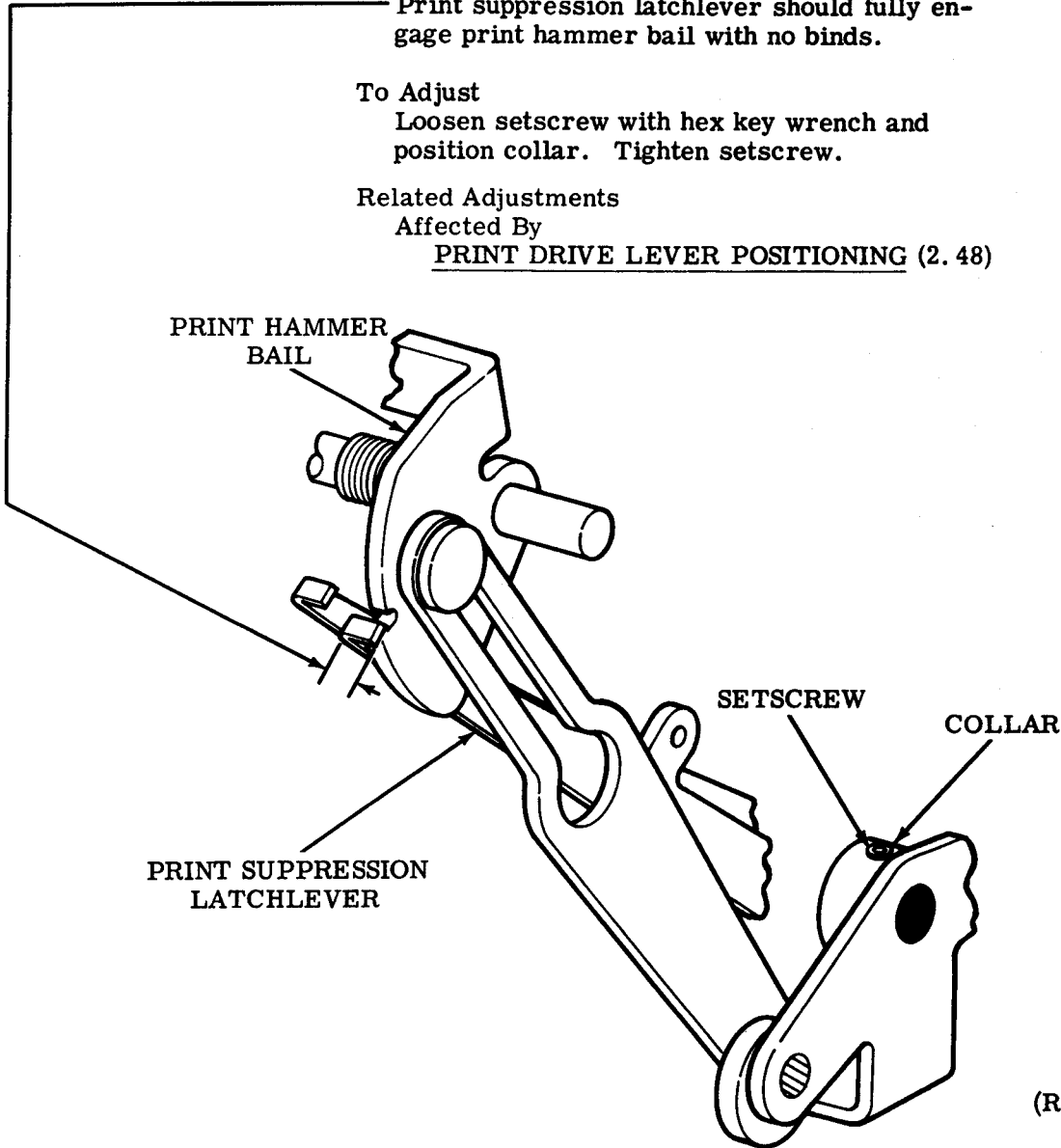

2.51 Carriage Area (continued)

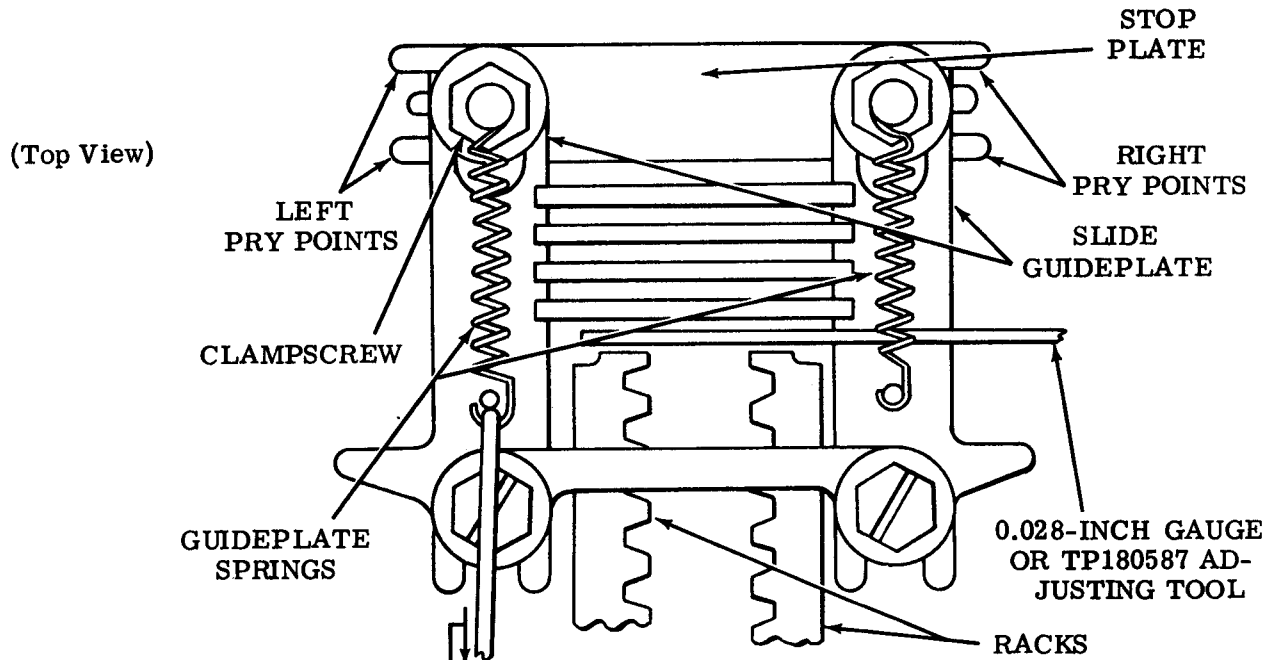
TYPEWHEEL POSITIONING (Preliminary)

Note 1: Final print alignment is found in 2.125.

To Check

Set up code combination in selector of a character in counterclockwise field of typewheel. Rotate main shaft until carriage drive bail is in rearmost position. Check to see if vertical row containing character is properly selected. Repeat for a character in clockwise field.

Requirement

Typewheel positioning correct in both clockwise and counterclockwise directions.

To Adjust

Place typing unit in stop condition. Open up LEFT SLIDE GUIDEPLATE RESET (2.53) and RIGHT SLIDE GUIDEPLATE RESET (2.52) adjustments. Loosen two clampscrews friction tight. Place either 0.028-inch gauge or TP180587 adjusting tool across end of racks. Fold reset lever in place and position stop plate so that entire slide assembly is tight against racks and tool.

Related AdjustmentsAffects

LEFT SLIDE GUIDEPLATE RESET (2.53)
RIGHT SLIDE GUIDEPLATE RESET (2.52)

SLIDE GUIDEPLATE SPRINGS

Note 1: To check slide guideplate springs, it is necessary to remove the carriage mechanism from the typing unit. See appropriate disassembly and reassembly section. Do not check unless there is reason to believe that the slide guideplate springs will not meet their requirement.

Requirement

Min 1 oz---Max 3 oz _____
to pull each spring to installed length.

Note 2: Check right and left springs.

2.52 Carriage Area (continued)

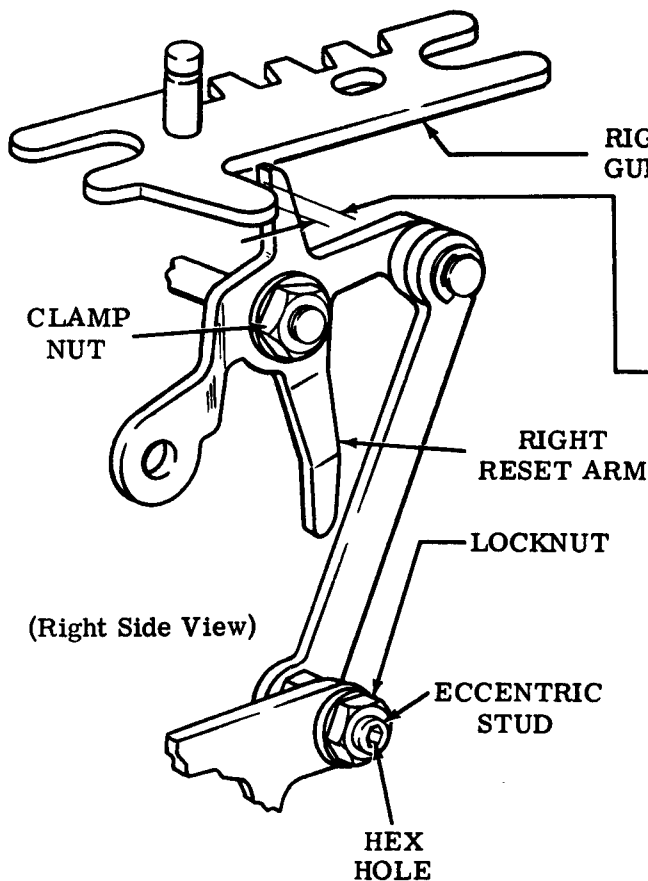

RIGHT SLIDE GUIDEPLATE RESET

Requirement

With typing unit in stop condition
Min some---Max 0.015 inch
between right slide guideplate and the right
reset arm when right and left slide guide-
plates are held toward front to make clear-
ance a maximum.

To Adjust

Loosen eccentric stud locknut. Rotate
eccentric stud with hex wrench in hex hole.
Tighten locknut.

Related Adjustments

Affects

- LEFT SLIDE GUIDPLATE RESET (2.53)
- PRINT HAMMER TRIP LEVER
- RELEASE (2.54)
- RIBBON POSITIONING (2.56)

Affected By

- REAR RAIL POSITION (2.45)
- REAR ROLLER CLEARANCE (2.46)
- PRINT DRIVE LEVER POSITIONING
(2.48)
- TYPEWHEEL POSITIONING (2.51)

2.53 Carriage Area (continued)

LEFT SLIDE GUIDEPLATE RESET**Requirement**

With typing unit in stop condition

Min some---Max 0.015 inch
between left slide guideplate and left reset
arm when the right and left slide guide-
plates are held toward the front to make
clearance a maximum.

To Adjust

Loosen left reset arm clamp nut. Position
left reset arm using pry point. Tighten
clamp nut.

Related Adjustments**Affects**

RIBBON POSITIONING (2.56)

Affected By

REAR RAIL POSITION (2.45)
PRINT DRIVE LEVER POSITIONING (2.48)
TYPEWHEEL POSITIONING (2.51)
RIGHT SLIDE GUIDEPLATE RESET (2.52)

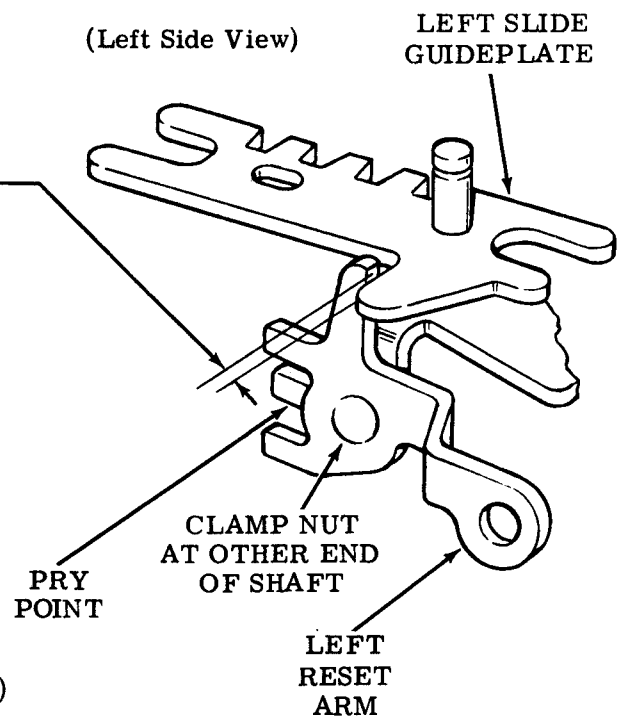

2.54 Carriage Area (continued)

PRINT HAMMER TRIP LEVER RELEASE

(Right Side View)

To Check

Place carriage at left margin. Rotate main shaft until carriage drive bail reaches its rearmost position. Take up play to minimize required clearance.

(1) Requirement

Min 0.040 inch---Max 0.110 inch between print hammer bail and print hammer trip lever.

To Adjust

Loosen print hammer trip lever clampscrew and position print hammer trip lever using pry point. Tighten clampscrew.

(2) Requirement

With carriage at the right margin, clearance between print hammer bail and print hammer trip lever to be within 0.020 inch of Requirement (1) above.

To Adjust

With carriage drive bail right pivot clampscrew friction tight, position right pivot. Tighten clampscrew.

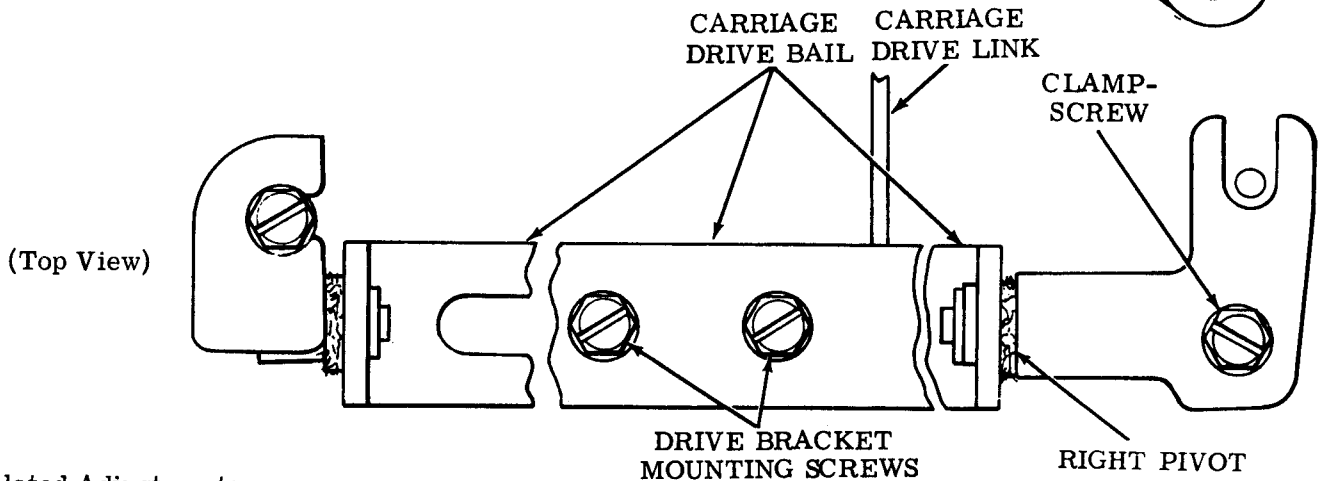
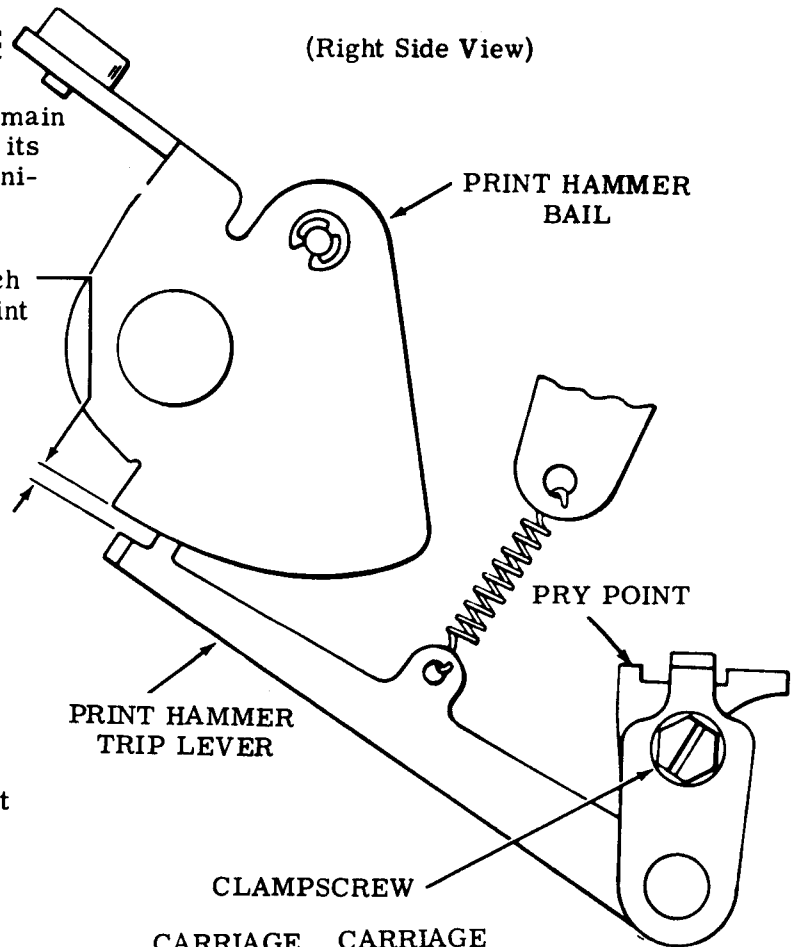

Related Adjustments

Affects

FEED PAWL STOP POSITION (Spacing Area) (2.64)
PRINT HAMMER TRIP LEVER RESET (2.55)

RIGHT SLIDE GUIDEPLATE RESET (2.52)
REAR RAIL POSITION (2.45)
REAR ROLLER CLEARANCE (2.46)

2.55 Carriage Area (continued)

PRINT HAMMER TRIP LEVER RESET**Requirement**

With typing unit in stop condition

Min 0.010 inch---Max 0.050 inch
between print hammer bail and print
hammer trip lever.

To Adjust

Loosen clamp nut and position print
hammer reset arm eccentric pivot
with hex key wrench in hex hole.
Tighten clamp nut.

Note: Keep high part of eccentric
pivot toward front of typing unit.

Related Adjustment**Affected By**

REAR RAIL POSITION (2.45)

REAR ROLLER CLEARANCE (2.46)

PRINT DRIVE LEVER POSITIONING (2.48)

PRINT HAMMER TRIP LEVER RELEASE (2.54)

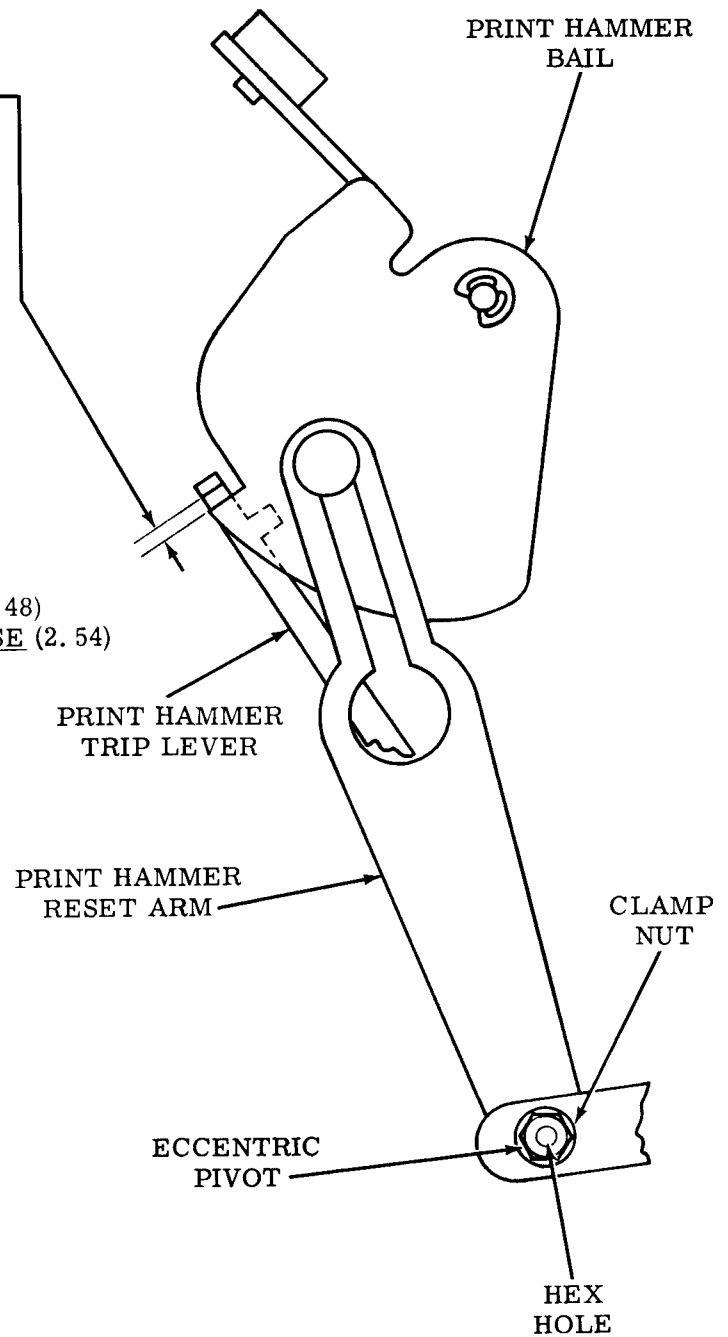

2.56 Carriage Area (continued)

Note: Do not perform the following adjustment on typing units equipped with the two-color printing feature. Typing units with TP186732 ribbon link do not require this adjustment.

RIBBON POSITIONING**To Check**

Trip function clutch and rotate main shaft until carriage drive bail is in its rearmost position. Continue rotating main shaft until the right ribbon link, during its downward travel, just contacts the top surface of the ribbon guide.

Requirement

Min some---Max 0.010 inch
between the left ribbon link and the ribbon guide as gauged by eye.

To Adjust

Loosen left reset arm clamp nut. Position eccentric stud using hex key wrench in hex hole. Tighten clamp nut.

Related Adjustments**Affected By**

LEFT SLIDE GUIDEPLATE RESET (2.53)
PRINT DRIVE LEVER POSITIONING (2.48)
RIGHT SLIDE GUIDEPLATE RESET (2.52)

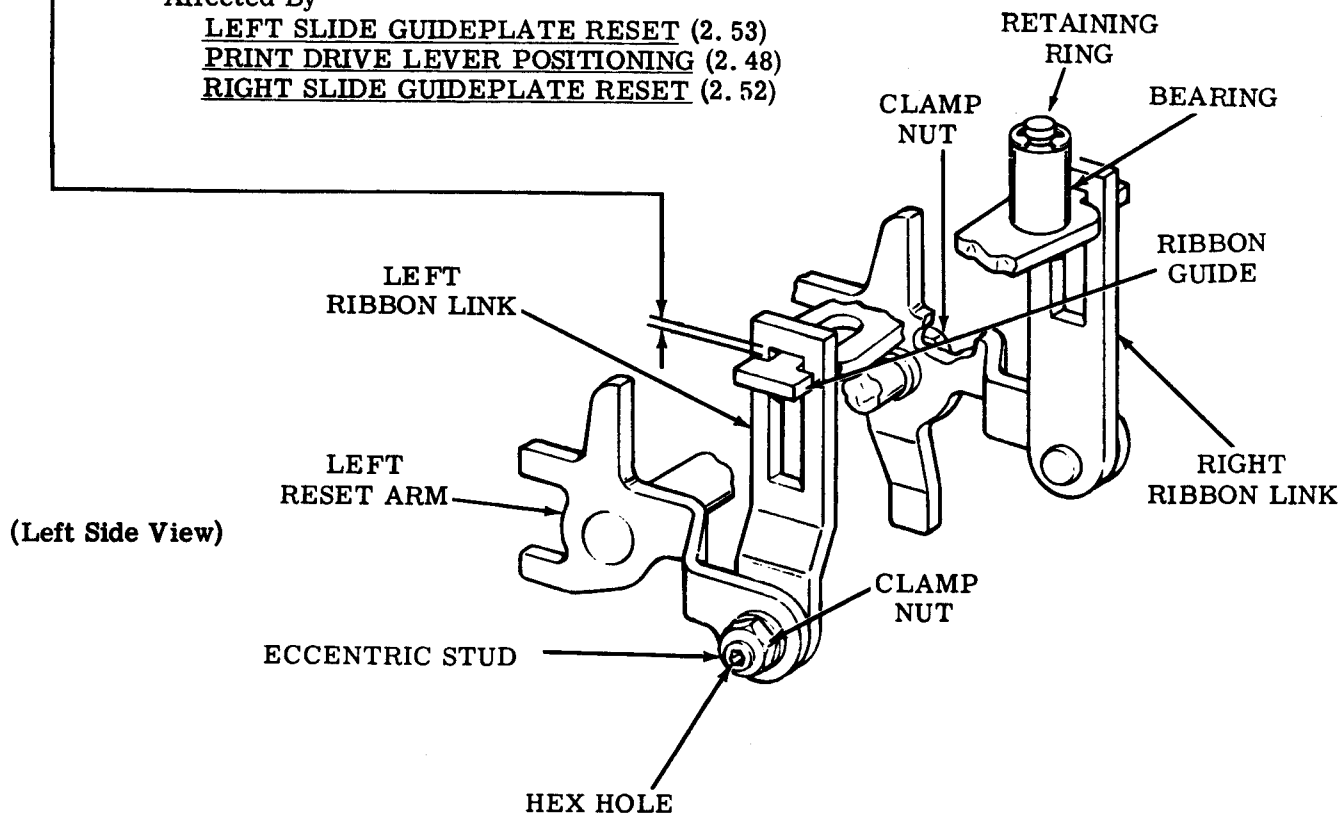

2.57 Carriage Area (continued)

PRINT SUPPRESSION LATCHLEVER RELEASE

To Check

Place carriage approximately 1/2 inch from left margin. Set up the "T" (--3-5-78) code combination in the selector. Rotate main shaft until the carriage drive bail reaches its rearmost position. The print suppression codebar must be all the way (fully) up.

Requirement

Min 0.015 inch---Max 0.055 inch
between print suppression latchlever and print hammer bail when play in print suppression latchlever is taken up to make gap a minimum.



To Adjust

With print suppression latchlever held against print hammer bail, bend print suppression latchlever using pry points.

Note: Use top pry point to make gap larger. Use bottom pry point to make gap smaller.

Related Adjustments

Affected By

CODEBAR RESET LEVER POSITION (Function Area) (2.28)

FRONT ROLLERS CLEARANCE (2.43)

REAR RAIL POSITION (2.45)

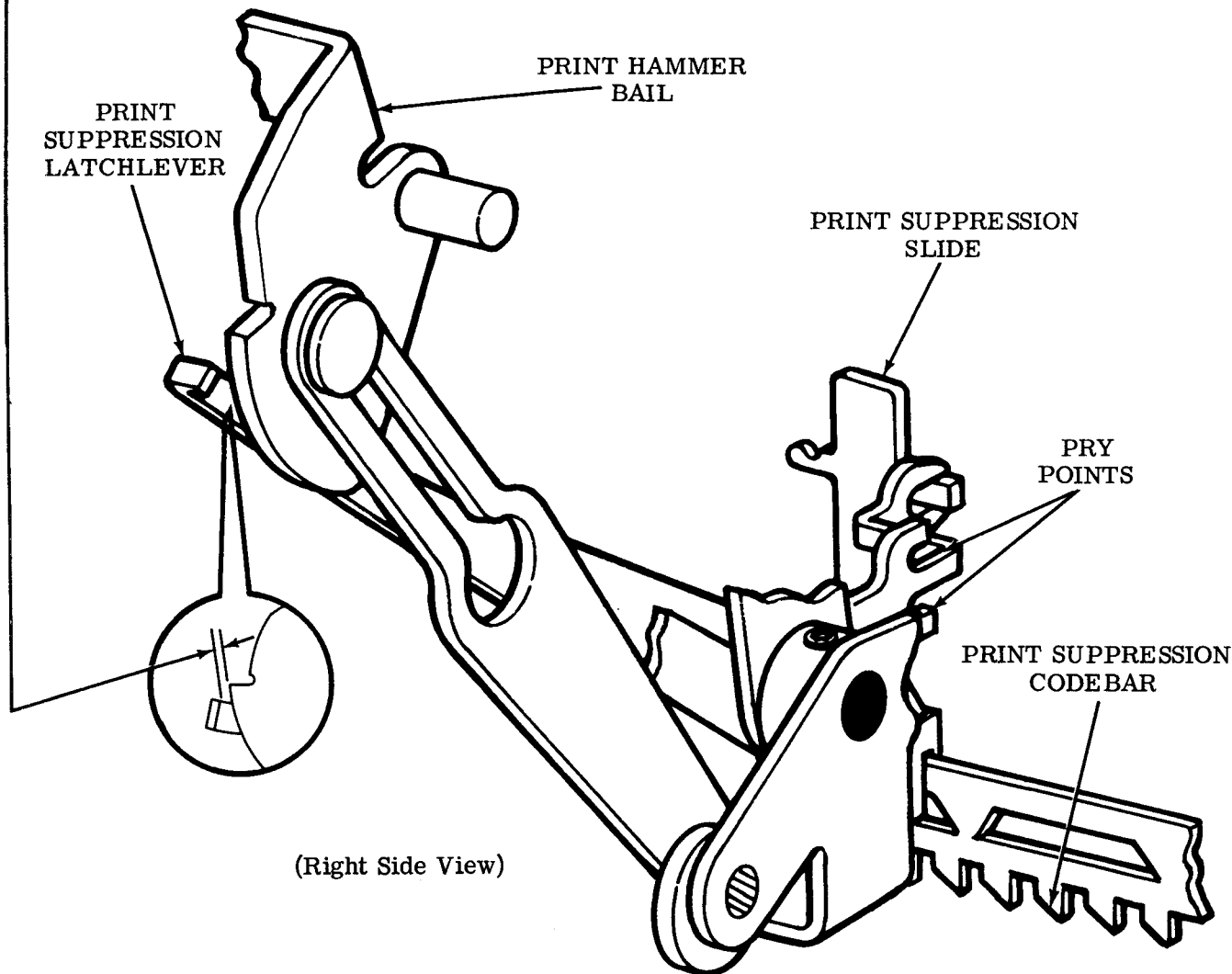

2.58 Carriage Area (continued)

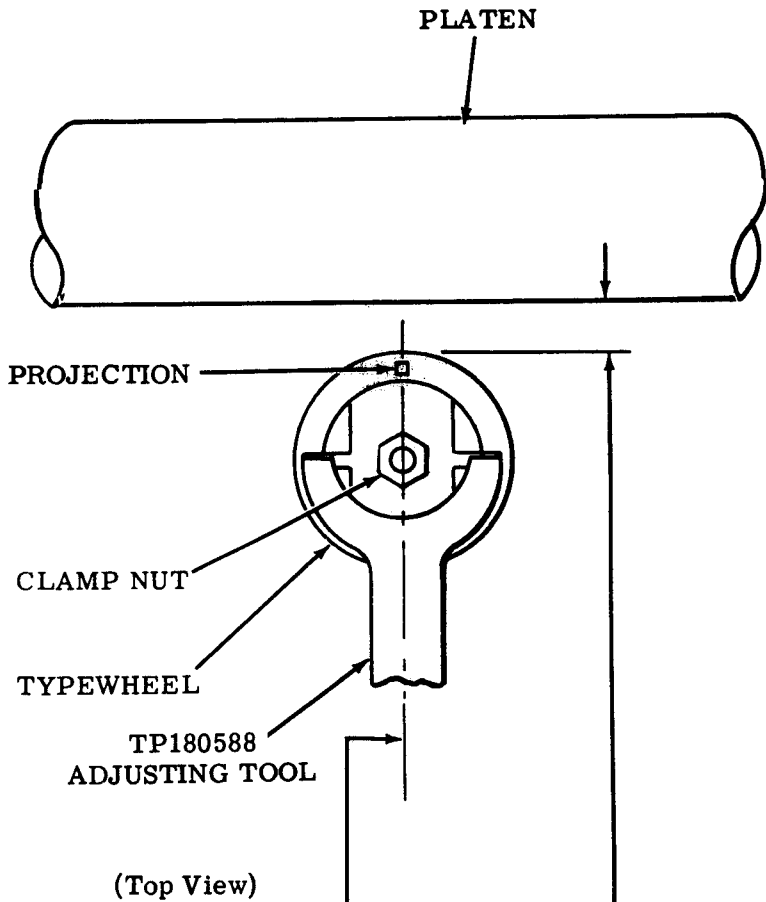

TYPEWHEEL "HOME" POSITION
(Preliminary)

To Check

Place typing unit in the stop condition.

(1) Requirement

The typewheel top surface projection should be at its closest position to the platen.

(2) Requirement

The typewheel top surface projection and the clamp nut should be aligned perpendicular to the platen, as gauged by eye.

To Adjust

Loosen clamp nut and position typewheel using TP180588 adjusting tool. Tighten clamp nut.

Related Adjustments

Affects

FINAL PRINTING ALIGNMENT (2.125)

2.59 Carriage Area (continued)

PRINT HAMMER BAIL SPRING

Requirement

With typing unit in stop condition
 Min 3 oz---Max 4-1/2 oz
 to start print hammer moving.

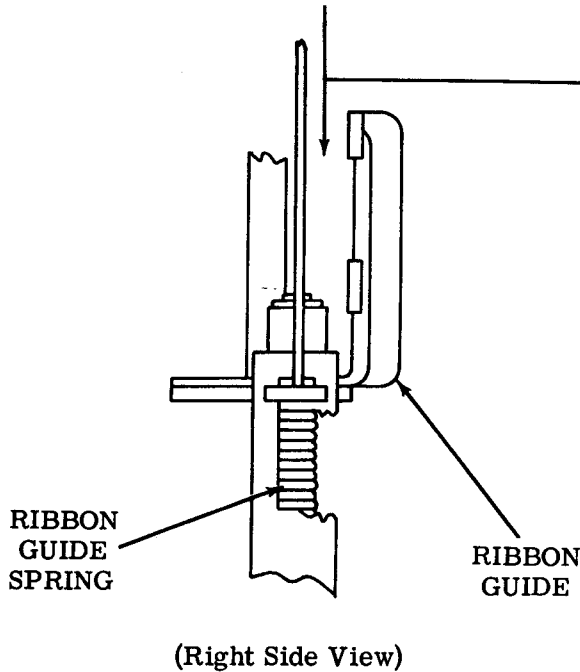
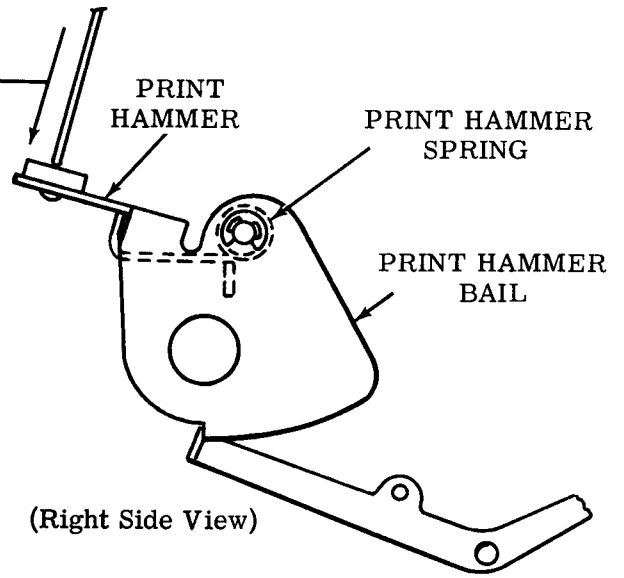

RIBBON GUIDE SPRING

To Check

Remove ribbon from ribbon guide. Trip selector clutch and rotate main shaft until carriage drive bail is in rearmost position.

Requirement

Min 6 oz---Max 9 oz
 to start ribbon guide moving.

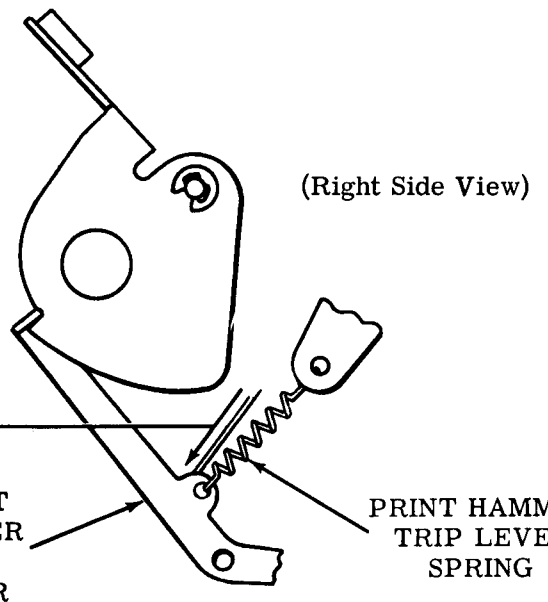

PRINT HAMMER TRIP LEVER SPRING

Requirement

With typing unit in stop condition
 Min 1 oz---Max 2-1/2 oz
 to start print hammer trip lever moving.

2. 60 Carriage Area (continued)

ROTARY DRIVE BAIL SPRING

To Check

Set up an all marking code combination in selector and rotate main shaft until the carriage drive bail is in its rear-most position.

Requirement

Min 17 oz---Max 21-1/2 oz to start rotary drive bail moving.

VERTICAL DRIVE BAIL SPRING

Requirement

With typing unit in stop condition
Min 13 oz---Max 18 oz to start typewheel moving.

TYPEWHEEL RETURN SPRING

Requirement

With typing unit in stop condition
Min 2-1/2 oz---Max 4-1/2 oz to move typewheel to platen.

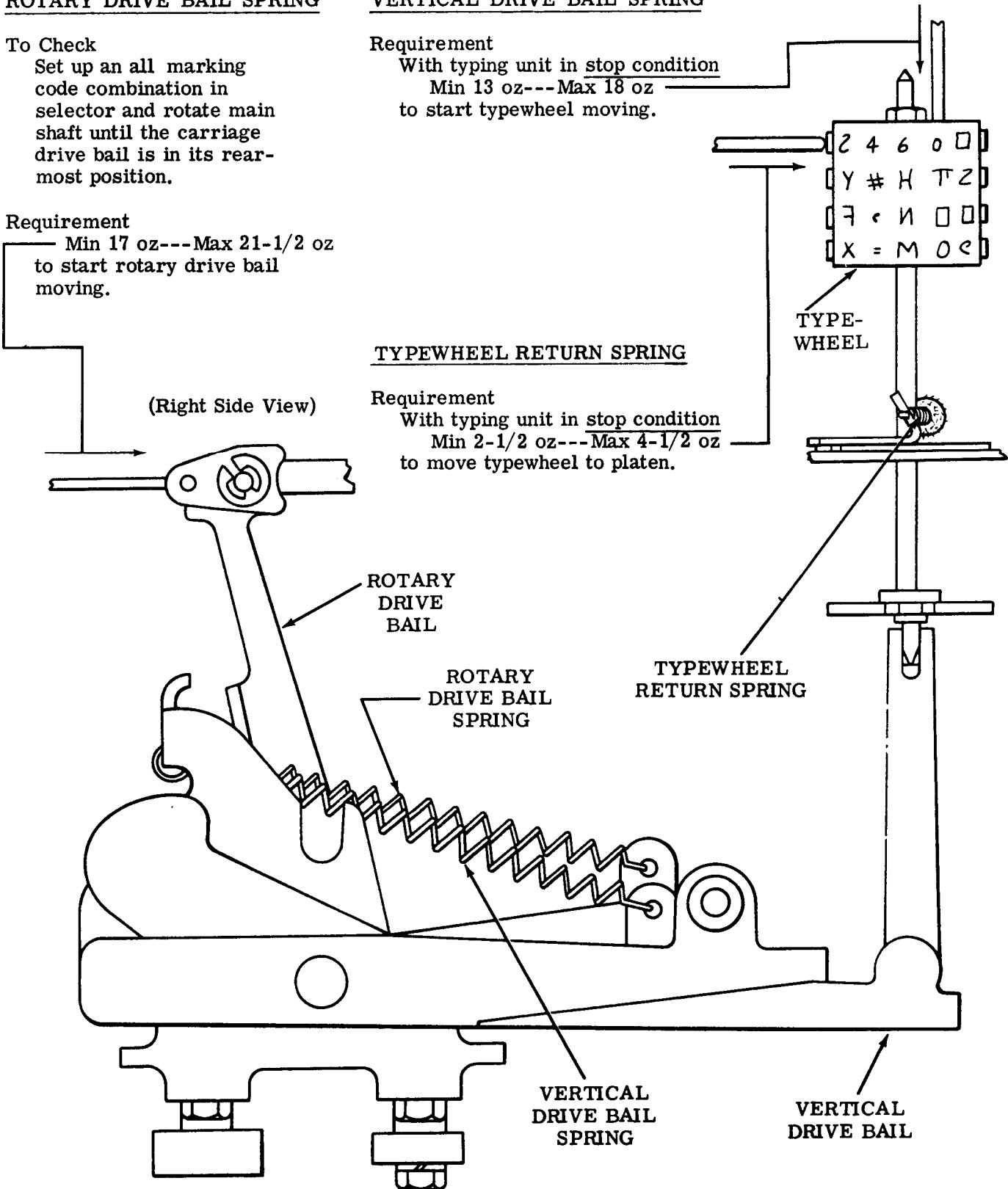

2. 61 Carriage Area (continued)

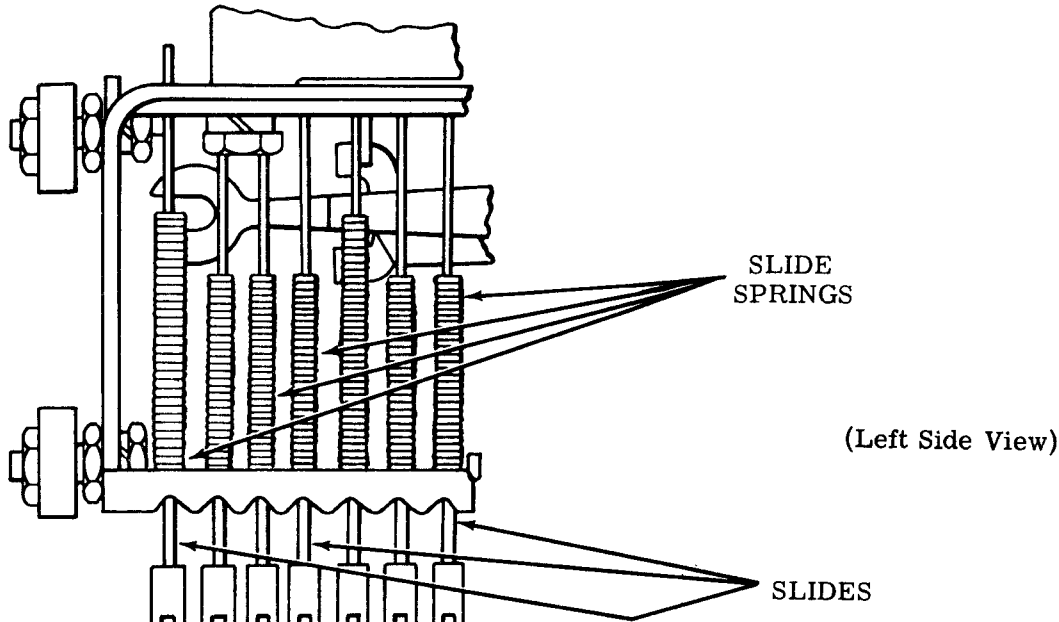

SLIDE SPRINGS

Note: To check tensions of the slide springs, it is necessary to remove the carriage mechanism from typing unit. For instructions see appropriate disassembly and reassembly section. Do not check unless there is reason to believe that the slide springs do not meet their requirements.

Requirement

With carriage power bail in its stop position, towards the front, it should require values as shown in chart, to start slides moving.

* Print Suppression

SLIDE NO.	5 AND 7	4	2 AND 3	1	PS*
Min	1/4 oz	3-3/4 oz	2 oz	1/4 oz	3-3/4 oz
Max	1-1/4 oz	4-1/2 oz	3 oz	1 oz	4-1/2 oz

2.62 Carriage Area (continued)

RIBBON POWER LEVER DRIVE

(1) To Check

Manually operate the typing unit until the carriage drive bail is in the rearmost position. Rotate left ribbon ratchet until the ribbon spool shaft and ribbon spool pin are approximately aligned with the tip of the feed pawl. Seat feed pawl against left ribbon ratchet.

Requirement

Min 0.010 inch---Max 0.045 inch
between face of left ribbon ratchet tooth and the corner tip of check pawl.

(2) To Check

Repeat (1) To Check above, except apply all instructions to right ribbon ratchet.

Requirement

Min 0.010 inch---Max 0.045 inch
between face of right ribbon ratchet tooth and corner tip of check pawl.

To Adjust

Loosen locknut and position the eccentric stud with hex key wrench in hex hole. Tighten locknut.

Note: Position eccentric stud to the bottom of its mounting slot when tightening locknut.

Related Adjustments

Affected By

- FRONT ROLLERS CLEARANCE (2.43)
- REAR RAIL POSITION (2.45)
- RESET LEVER POSITIONING (2.49)

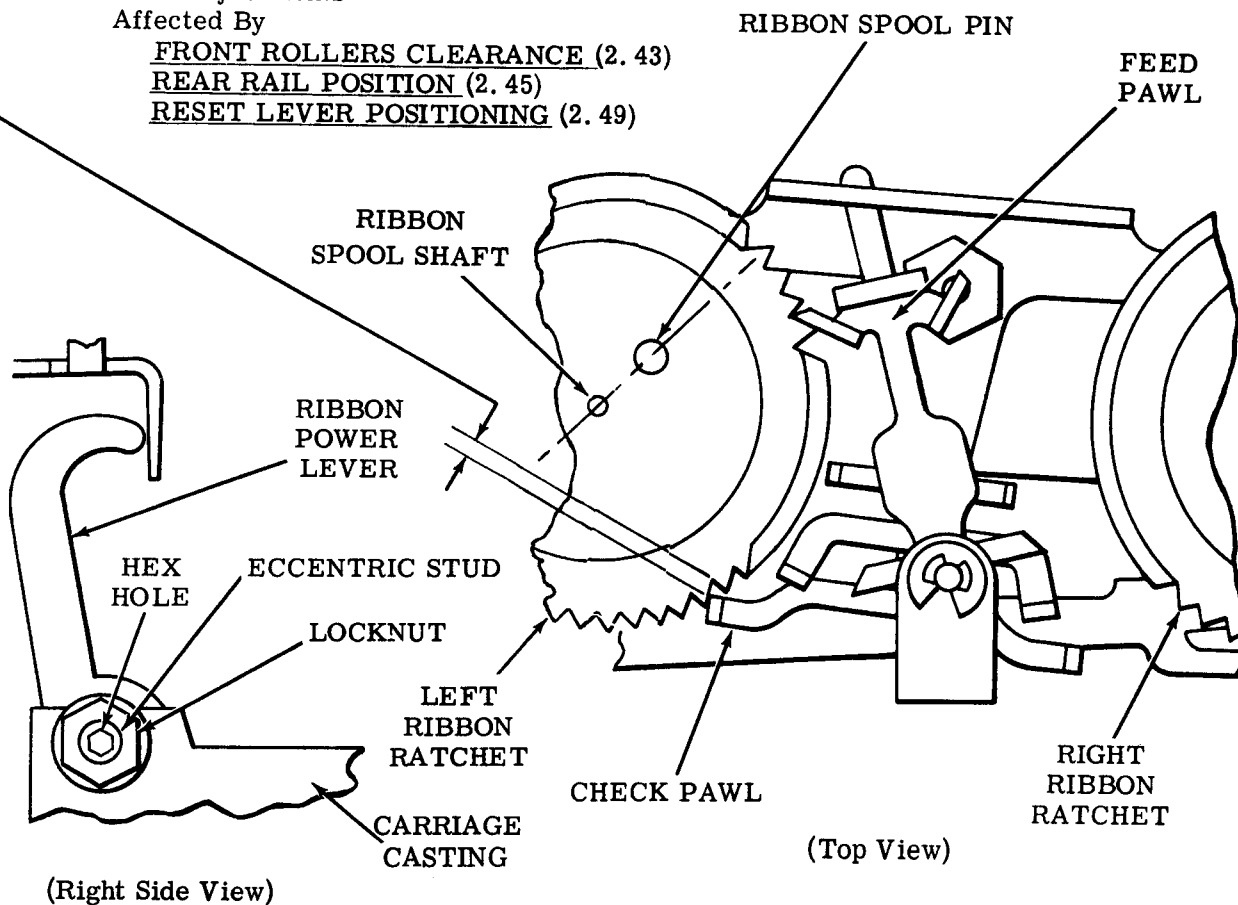

2. 63 Carriage Area (continued)

RIBBON RATCHET SPRING

Requirement

With feed and check pawls disengaged from ratchet wheel.

Min 1-1/2 oz---Max 3-1/2 oz
to start ratchet wheel moving.

RIBBON REVERSE ARM SPRING

Requirement

With typing unit in stop condition and ribbon removed

Min 1-1/2 oz---Max 3 oz
to start reverse arm moving.

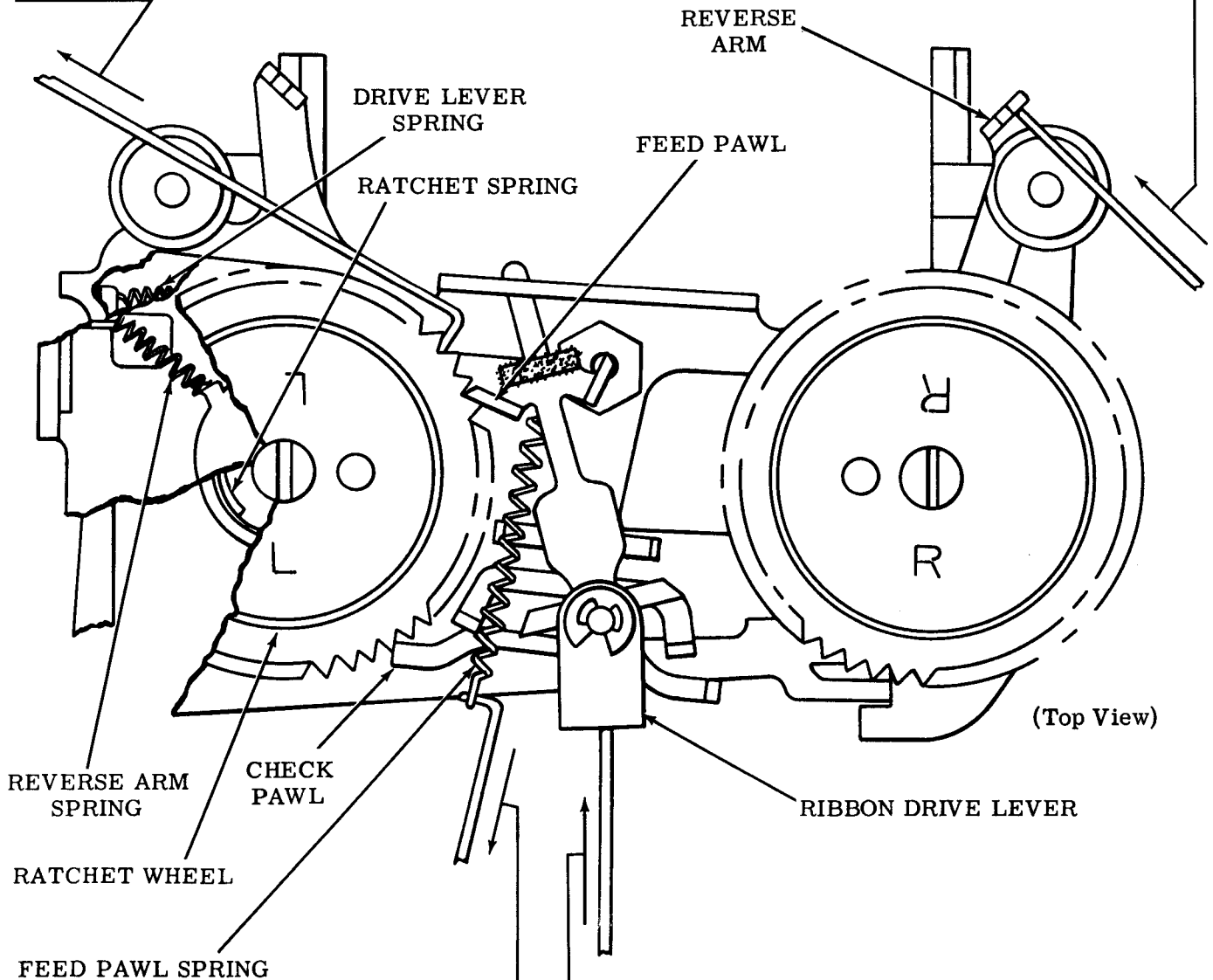

RIBBON FEED PAWL SPRING

Requirement

With typing unit in stop condition

Min 2-1/2 oz---Max 4 oz
to pull feed pawl spring to installed length.

RIBBON DRIVE LEVER SPRING

Requirement

With typing unit in stop condition

Min 5-1/2 oz---Max 9 oz
to start ribbon drive lever moving.

2.64 Spacing Area

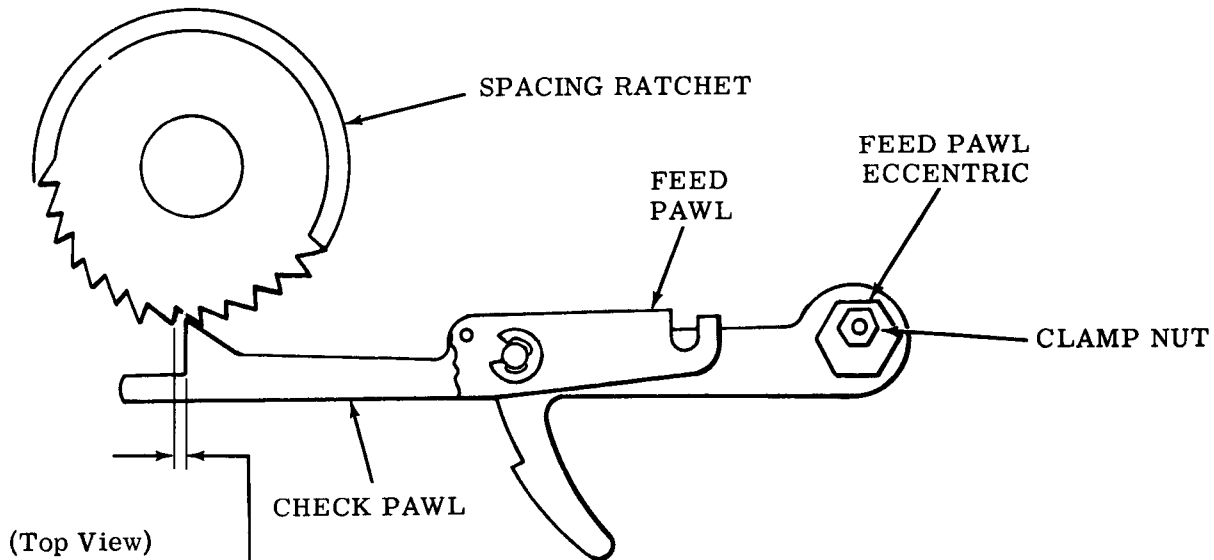

(Top View)

FEED PAWL STOP POSITION

To Check

Place carriage at center of platen. Place typing unit in stop condition.

Requirement

With feed pawl in full engagement with spacing ratchet
 — Min 0.004 inch---Max 0.018 inch
 between check pawl and spacing ratchet tooth.

To Adjust

Loosen clamp nut. Rotate feed pawl eccentric. Keep high part of eccentric toward front. Tighten clamp nut.

Related Adjustment

Affected By

PRINT HAMMER TRIP LEVER RELEASE
 (Carriage Area) (2.54)

SPACE BELLCRANK SPRING

Requirement

With typing unit in stop condition
 — Min 3 oz---Max 5 oz
 to start bellcrank moving.

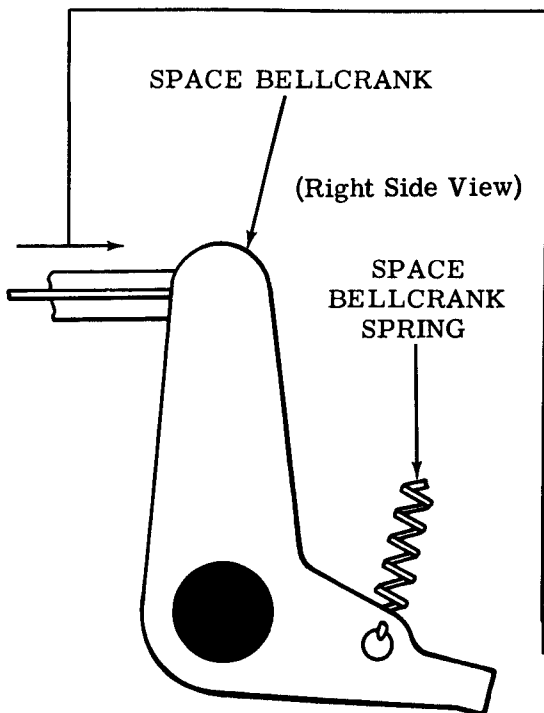

(Right Side View)

2. 65 Spacing Area (continued)

SPACE SUPPRESSION LEVER CLEARANCE — PRINTING**To Check**

Move carriage to the center of platen. Set up the @ code combination (-----78) in the selector. Rotate the main shaft until the front vertical surface of the right end of feed pawl is aligned with notch on space suppression lever.

(1) Requirement

With all play taken up to minimize gap
Min 0.005 inch--Max 0.040 inch
between right end of feed pawl and tip
of notch on the space suppression lever.

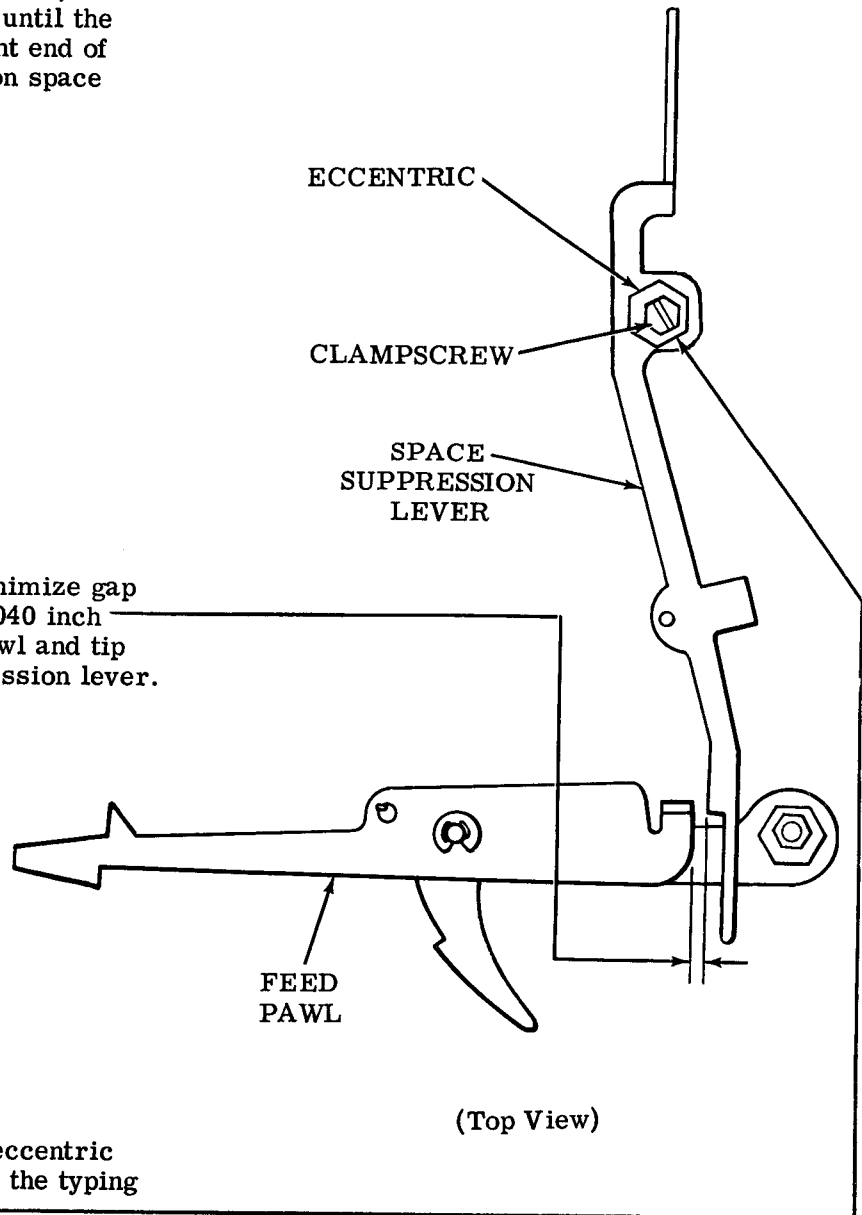
**(2) Requirement**

The position of high part of eccentric should be toward the rear of the typing unit.

To Adjust

Loosen eccentric clampscrew friction tight. Position eccentric. Tighten eccentric clampscrew.

Related Adjustment

Affected By

CODEBAR RESET LEVER POSITION
(Function Area) (2. 28)

2.66 Spacing Area (continued)

CARRIAGE RETURN LEVER SPRING

To Check

Place typing unit in stop condition and manually return carriage. Hold feed pawl and check pawl away from carriage return lever.

Requirement

Min 1 oz---Max 3 oz
to start carriage return lever moving.

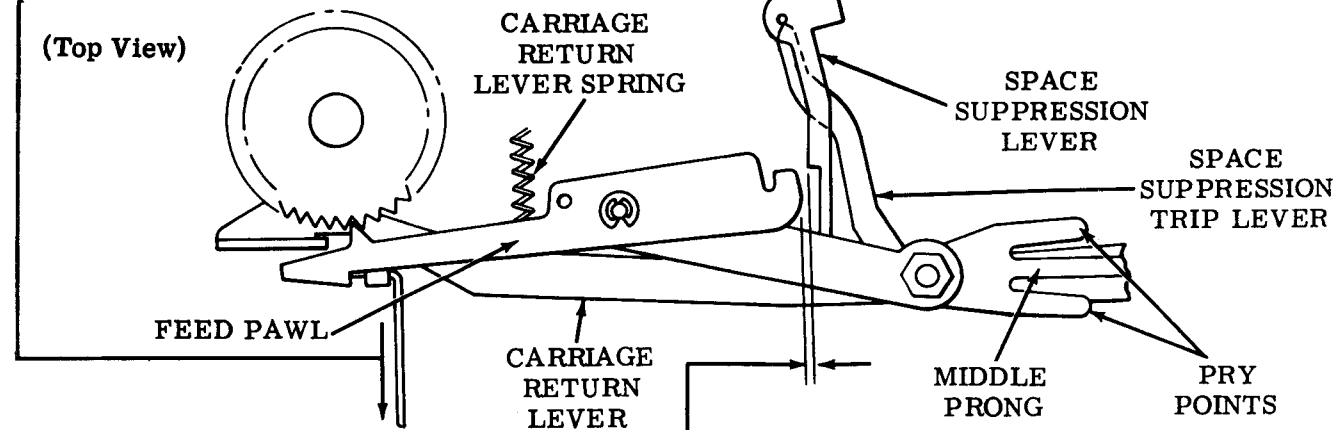

SPACE SUPPRESSION LEVER CLEARANCE — SPACING

→ (1) To Check

Move carriage to the center of platen. Set up space code combination (----6-8) in the selector. Rotate main shaft until front vertical surface of right end of feed pawl is aligned with notch on space suppression lever.

Requirement

With all play taken up to minimize gap
Min some---Max 0.040 inch
between right end of feed pawl and tip of notch on space suppression lever. Rotate main shaft through one complete revolution and check for horizontal motion of the space suppression lever. If motion occurs, refine requirement to min side and recheck.

To Adjust

Position space suppression trip lever by bending middle prong. Use front pry point to increase clearance. Use rear pry point to decrease clearance.

(2) To Check (Typing units with eccentric)
Move carriage to center of platen. Set up space code combination (----6-8) in selector. Rotate main shaft until front vertical surface of right end of feed pawl is aligned with notch on space suppression lever.

Requirement

Min 0.005 inch---Max 0.040 inch
between right end of feed pawl and tip of notch of space suppression lever. Take up all play to minimize clearance.

To Adjust

Loosen clamp nut and position eccentric keeping high part of eccentric toward bottom of unit. Rotate high part of eccentric to rear to increase gap and forward to decrease gap.

Related Adjustments

Affected By
LEFT ROCKER DRIVE (2.34)

2.67 Spacing Area

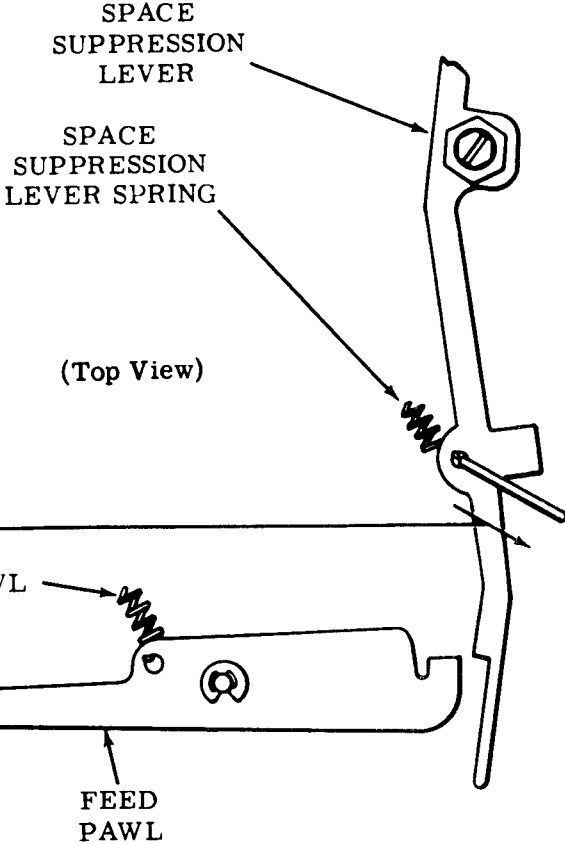

SPACE SUPPRESSION LEVER SPRING

Requirement
 With typing unit in stop condition
 Min 1-1/2 oz---Max 3 oz
 to start space suppression lever moving.

FEED PAWL SPRING

Requirement
 With typing unit in stop condition
 and feed pawl disengaged from
 spacing ratchet
 Min 2 oz---Max 4 oz
 to start feed pawl moving.

2.68 Spacing Area (continued)

FEED PAWL TRAVEL

To Check

Place carriage to left margin and set up the character M code combination (1-34--78) in selector. Rotate main shaft until carriage drive bail reaches its rearmost position. Hold check pawl away from ratchet. Hold check pawl away from ratchet.

To Adjust

Loosen clamp nut. Position spacing drive roller. Tighten clamp nut.

Related Adjustment Affected By

LEFT MARGIN POSITION - F (2.72)

Requirement

Min 0.005 inch---Max 0.030 inch between the feeding surface of the feed pawl and the face of ratchet.

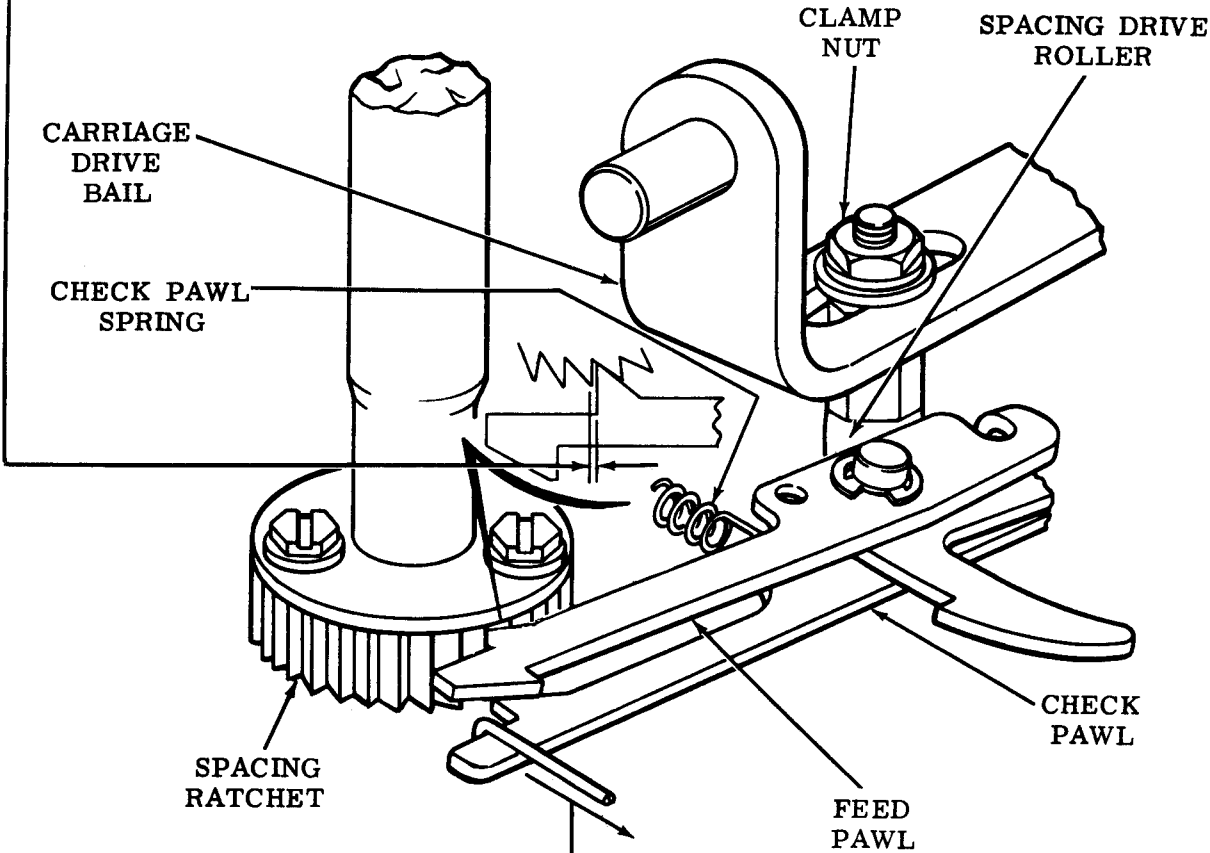

(Left Front View)

CHECK PAWL SPRING

Requirement

With typing unit in stop condition
Min 3/4 oz---Max 1-1/2 oz
to start check pawl moving.

2.69 Spacing Area (continued)

SPACING BELT TENSIONRequirement

With typing unit in stop condition, carriage at left margin, and from 8 to 11 ounces of pressure applied near center of belt

Min $9/16$ inch---Max $11/16$ inch between outer surfaces of belt.

To Adjust

Loosen mounting screws and position right pulley bracket. Tighten screws.

Related AdjustmentAffects

LEFT MARGIN PRINTING (2.120)

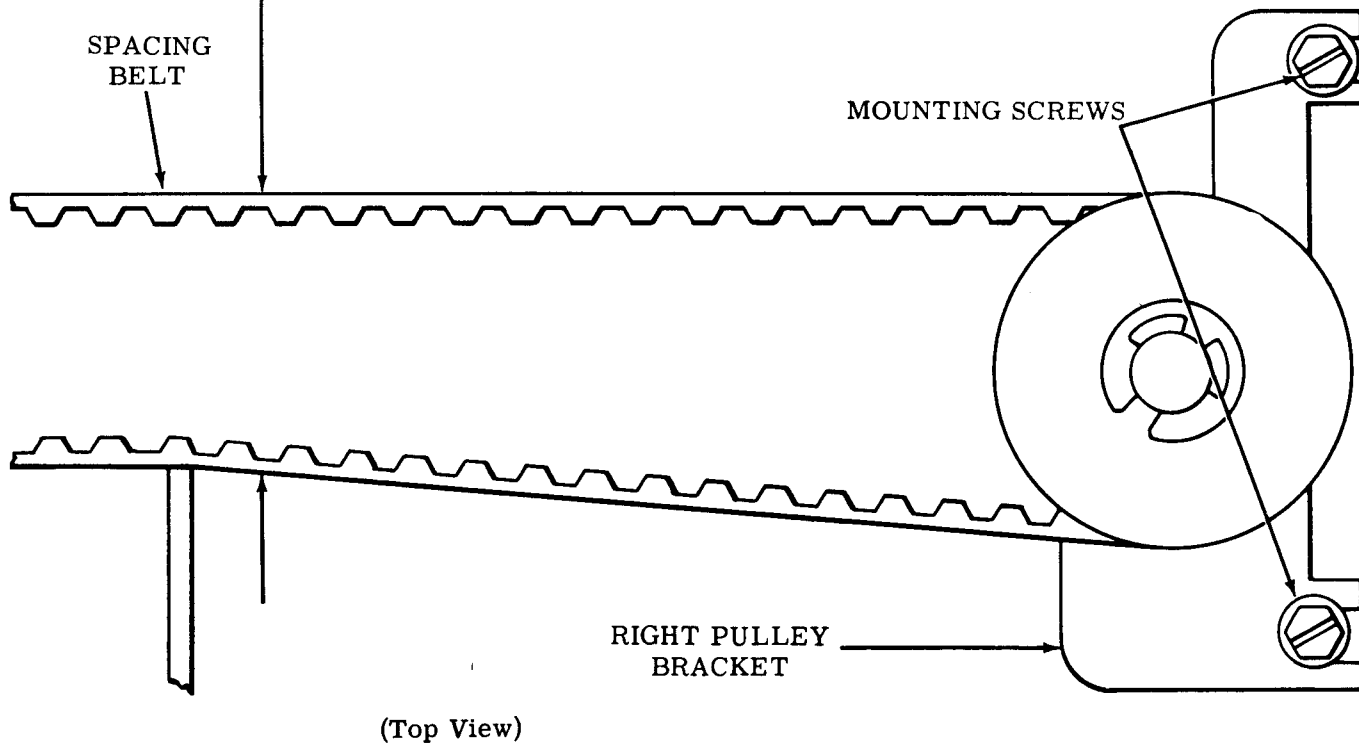

2.70 Platen Area

PLATEN — HORIZONTAL POSITION - F

(1) To Check

Place the flat surface on the left side of the platen up so that it is horizontal to the base casting. Place the carriage at the left margin and check requirement. Move the carriage to the right margin and again check requirement.

Requirement

Min 0.050 inch---Max 0.065 inch
between ribbon guide and platen at both left and right margins.

(2) To Check

Place carriage to center of platen and rotate platen until maximum clearance is obtained between platen and ribbon guide. Set up the E code combination (1-3---78) in the selector. Rotate main shaft until carriage drive bail is in its rearmost position. Push typewheel to the rear until it just touches the platen.

Note: The typing unit should not have paper or ribbon installed.

Requirement

Typewheel should not touch inside of either ribbon guide.

To Adjust

Loosen four horizontal positioning screws. Position platen horizontally. Tighten positioning screws.

Related Adjustments

Affects

LINE FEED STRIPPER PLATE CLEARANCE - F (2.85)

Affected By

FRONT ROLLERS CLEARANCE (2.43)

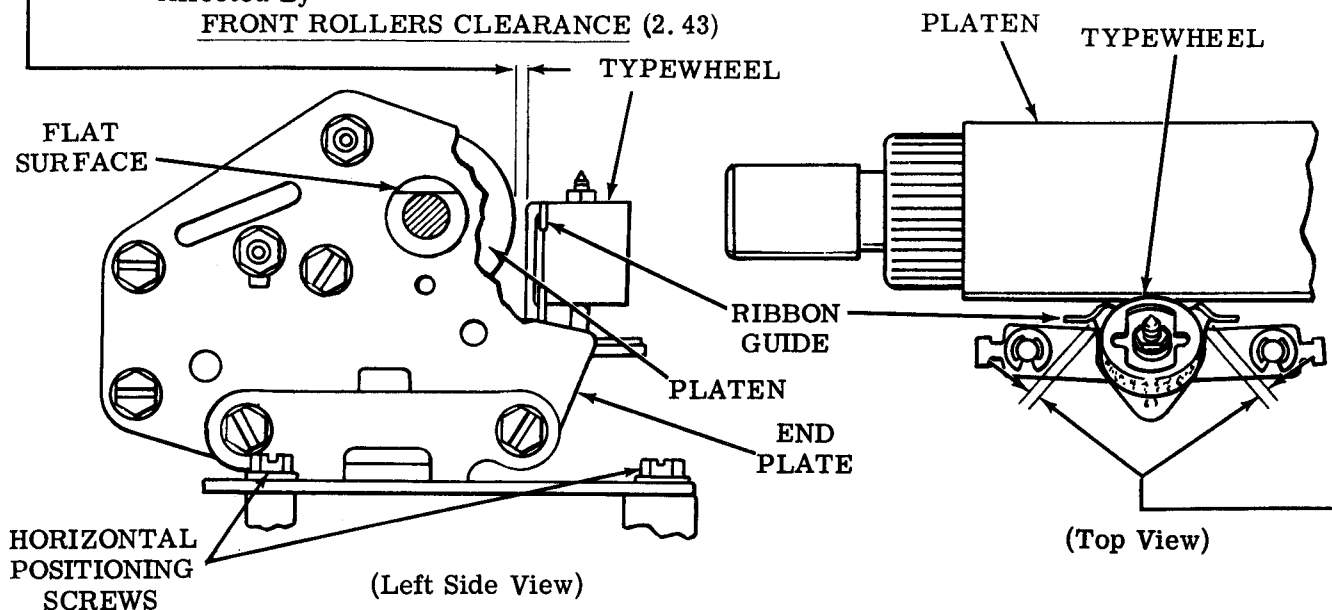

2.71 Platen Area (continued)

VERTICAL TYPE ALIGNMENT - F

For typing units equipped with adjustable vertical drive bail such as TP180606:

(1) To Check

Place paper and ribbon in unit. Place carriage to left margin. Set up the E code combination (1-3---78) in the selector and rotate the main shaft until the character is printed.

Requirement

When the printed character is examined by eye from top to bottom, the shading should be approximately the same with no overscoring or underscoring.

To Adjust

Loosen clampscrew on vertical drive bail and position the typewheel using pry point. Tighten adjusting screw.

(2) To Check

Place carriage to right margin. Set up the E code combination (1-3---78) in the selector and rotate main shaft until the character is printed.

Requirement

When the printed character is examined by eye from top to bottom, the shading should be approximately the same with no overscoring or underscoring.

To Adjust

Loosen vertical positioning screws on right side. Position the right end of the platen using pry point. Tighten positioning screws.

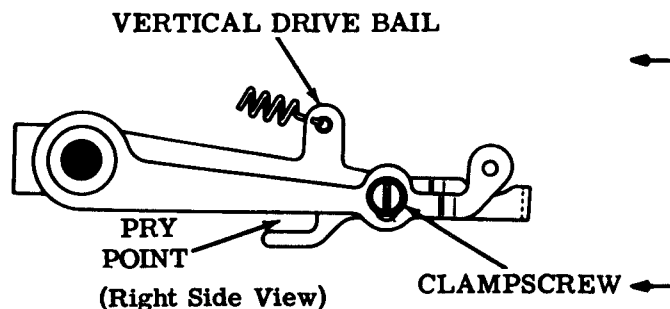

For typing units equipped with nonadjustable vertical drive bail such as TP180526:

To Check

Place paper in typing unit. Set up the E code combination (1-3---78) in the selector and rotate the main shaft until the character is printed. Repeat several times along the length of the platen.

Requirement

When each printed character is examined by eye from top to bottom, the shading should be approximately the same with no overscoring or underscoring.

To Adjust

Loosen four vertical positioning screws. Position the platen using pry points. Do not twist the platen. Tighten positioning screws.

Related Adjustments

Affects

- LINE FEED DRIVE ARM CLEARANCE - F
(2.80)
- LINE FEED PAWL DOWNSTOP POSITION - F
(2.83)
- LINE FEED UPSTOP BRACKET POSITION - F
(2.81)
- PRESSURE ROLLER CLEARANCE (2.84)
- LINE FEED DRIVE LINK POSITION - F
(2.82)

Affected By

- REAR RAIL POSITION (2.45)
- PRINT DRIVE LEVER
POSITIONING (2.48)

VERTICAL
POSITIONING
SCREWS

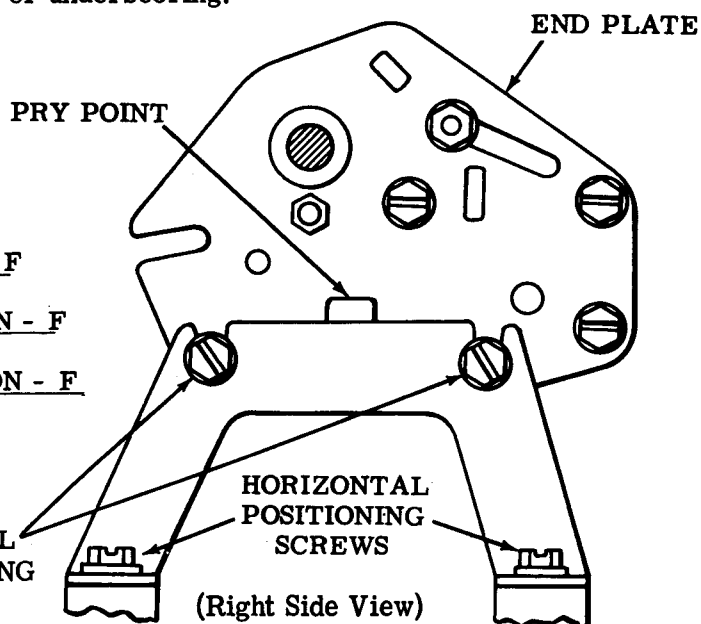

2.72 Platen Area (continued)

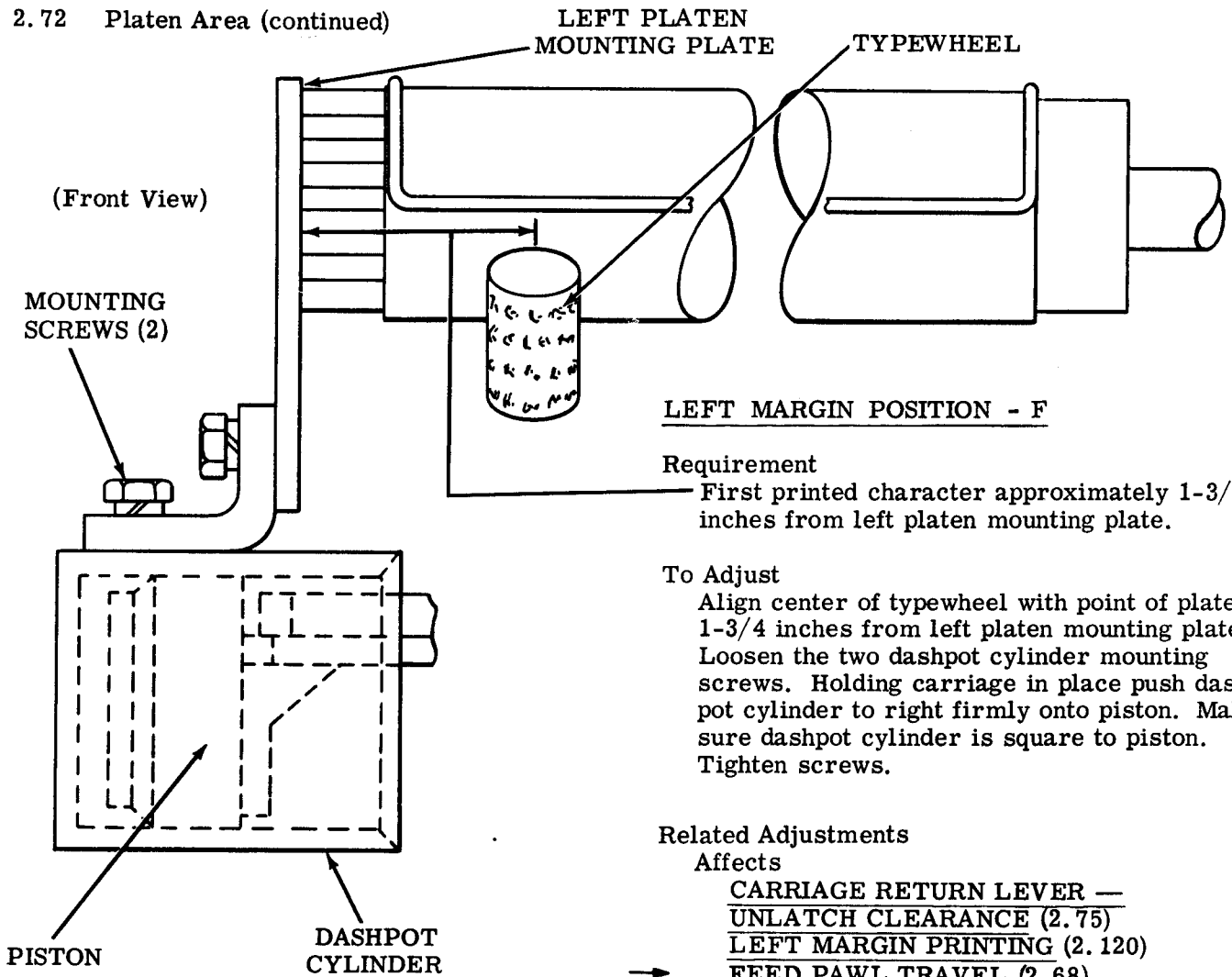

2.73 Function Area (continued)

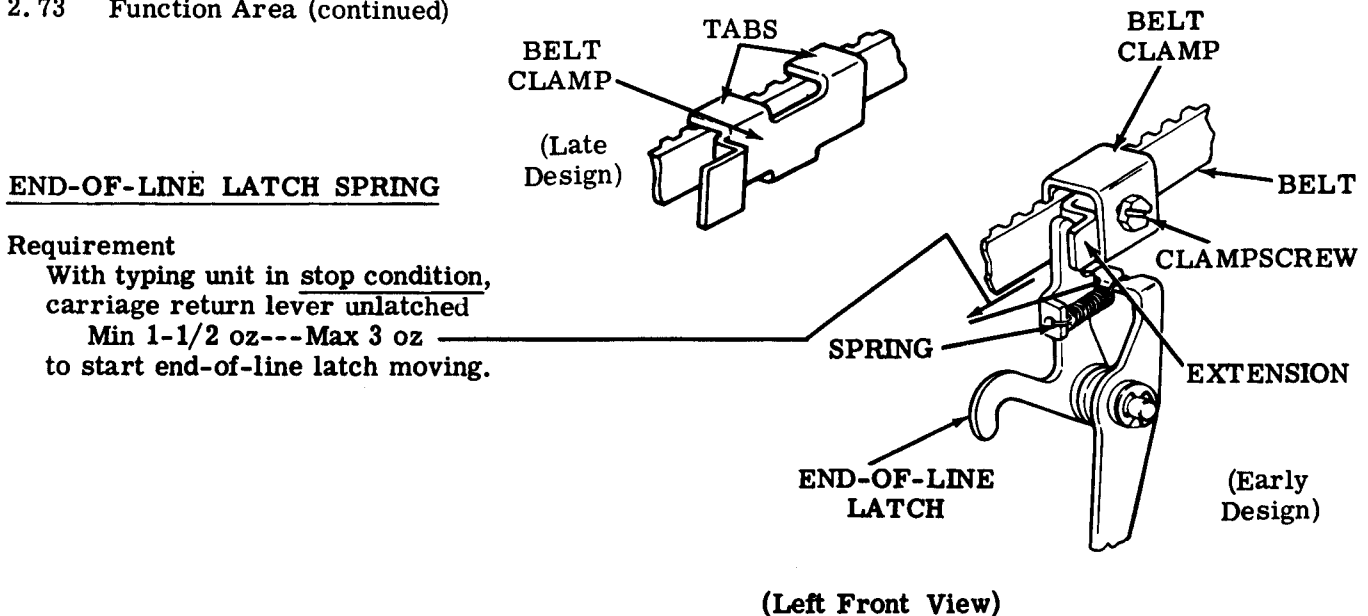

2.74 Platen Area (continued)

PAPER GUIDE SPRINGS - F

Requirement

With scale at either the left or right end of paper guide

Min 1-1/2 oz---Max 3-1/2 oz
to start paper guide moving.

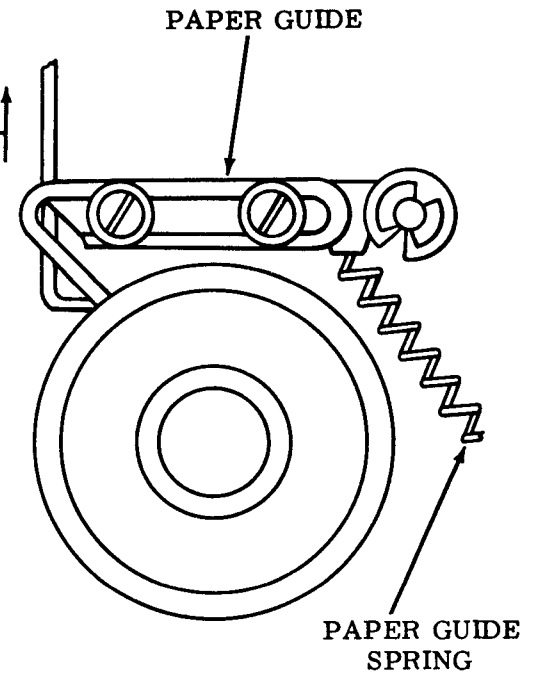

(Right Side View)

PAPER STRAIGHTENER BAIL SPRING - F

Requirement

With scale at center of paper straightener bail

Min 1 oz---Max 3 oz
to start paper straightener bail moving.

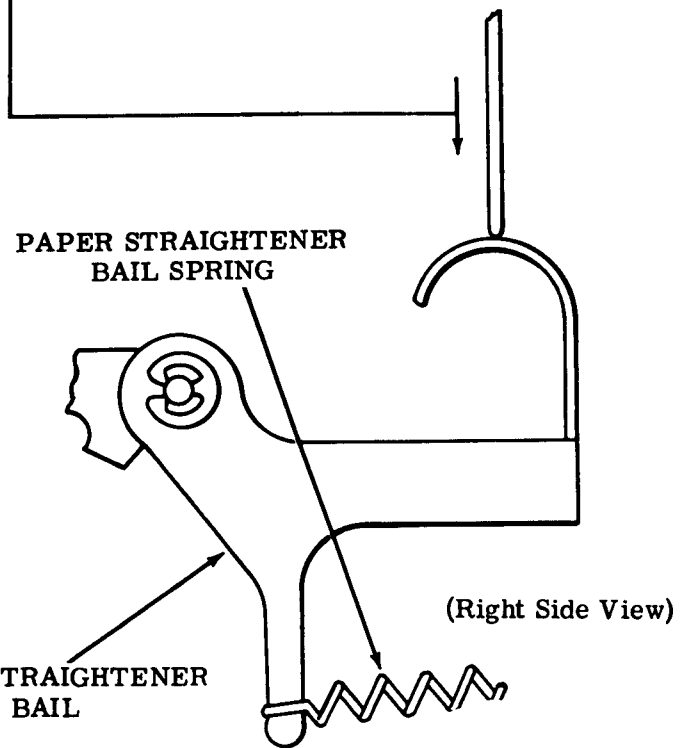

(Right Side View)

PAPER GUIDEPLATE SPRINGS - F

Requirement

With pressure lever released

Min 3/4 oz---Max 1-3/4 oz
to start paper guideplate moving.

Note: Check each of two springs.

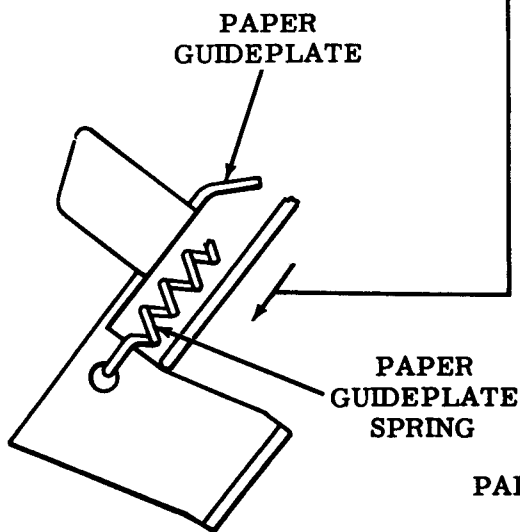

(Right Side View)

2.75 Spacing Area (continued)

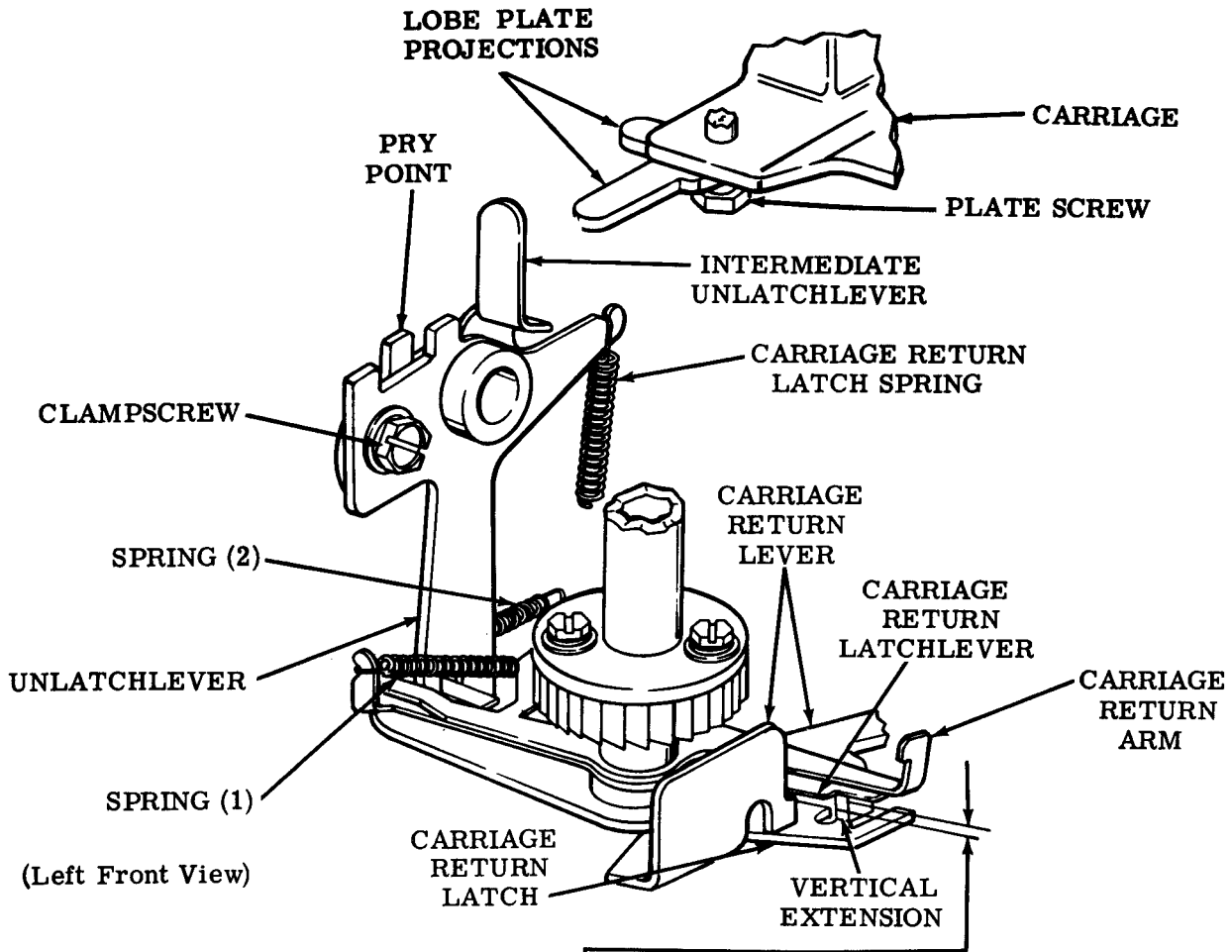

CARRIAGE RETURN LEVER — UNLATCH CLEARANCE

(1) To Check

Move carriage to left margin by placing carriage return lever in its forward latched position. Take up all play to minimize the required clearances.

Requirement

Min some---Max 0.050 inch between the carriage return latch and the vertical extension of the carriage return lever.

To Adjust

Loosen clampscrew. Use pry points to position carriage return latch. Tighten clampscrew.

Note: Perform the following check only if the typing unit is being completely readjusted.

(2) To Check

Repeat To Check (1) above.

Requirement

The intermediate unlatch lever should be aligned with the lobe plate projection which most nearly touches it.

To Adjust

Loosen plate screw. Position lobe projection plate. Tighten plate screw. Check FRONT ROLLERS CLEARANCE adjustment.

Related Adjustments

Affected By

- LEFT MARGIN POSITION - S (2.118)
- LEFT MARGIN POSITION - F (2.72)

2.76 Spacing Area (continued)

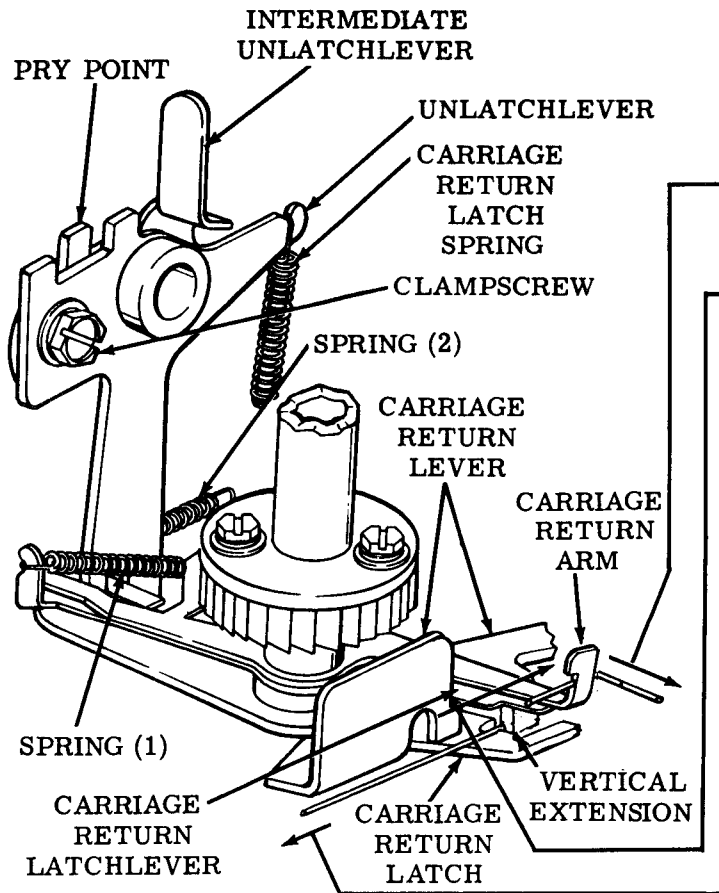

CARRIAGE RETURN ARM SPRINGS

To Check

Place typing unit in stop condition and engage feed pawl and check pawl with spacing ratchet.

(1) Requirement

Min 1 oz---Max 2 oz to start arm moving.

(2) Requirement

Min 1/2 oz---Max 1-1/2 oz to start arm moving.

CARRIAGE RETURN LATCH SPRING

To Check

With typing unit in stop condition and carriage return lever unlatched, place carriage away from left margin.

Requirement

Min 1-1/2 oz---Max 3 oz to start carriage return latch moving.

CARRIAGE BOUNCE

To Check

Place carriage at right margin, manually disengage the check pawl and feed pawl of the spacing mechanism.

Requirement

No pneumatic or mechanical bounce of carriage upon its return.

To Adjust

Loosen orifice adjusting plate clampscrew and close the orifice completely. Then gradually open until pneumatic bounce is eliminated while operating unit. Tighten clampscrew.

Note: The orifice should never become fully uncovered. If it does become fully uncovered, it is possible that the lobe plate projection may be broken.

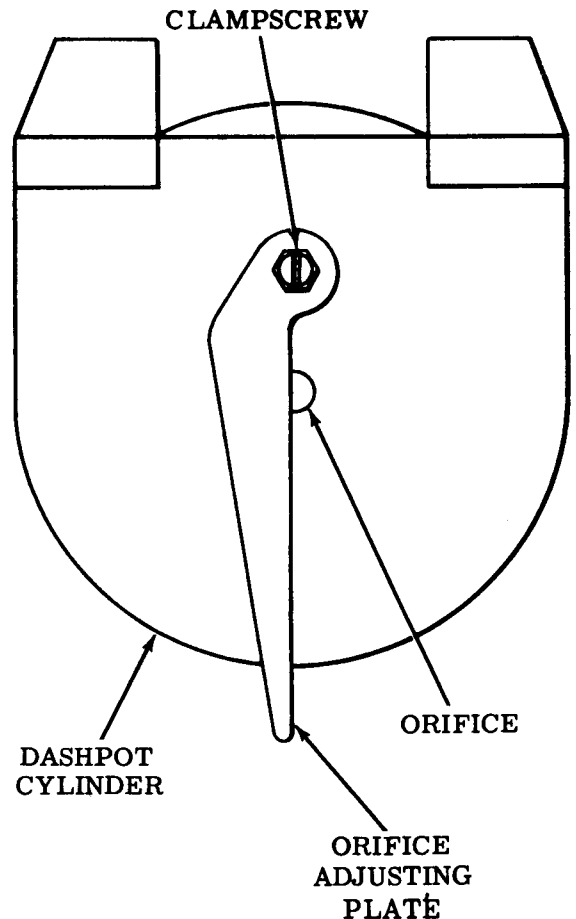

2.77 Platen Area (continued)

LINE FEED SELECTION - F

(1) Requirement

Upstop stud should be at bottom of slot for single line feed or at top for double line feed.

To Adjust

Loosen clamp nut. Position upstop stud. Tighten clamp nut.

Note: The following requirement applies only to typing units equipped with operator-controlled line feed feature containing TP185788 shift lever.

(2) Requirement

Same as Requirement (1) above.

To Adjust

Place TP185788 shift lever in upper detent for single line feed or in lower detent for double line feed.

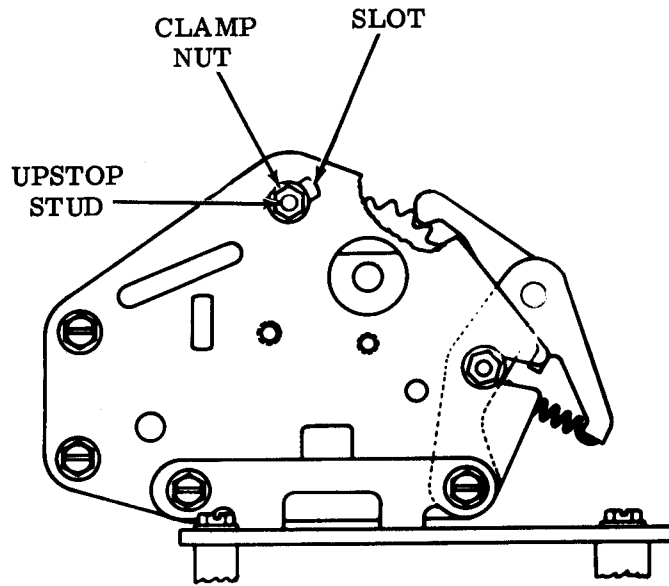

(Left Side View)

Related Adjustments

Affects

DETENT POSITION - F (2.78)

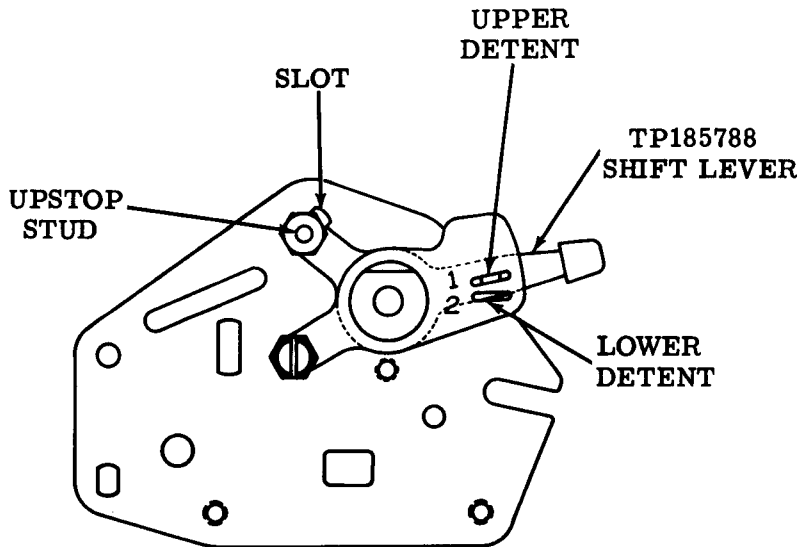

(Left Side View)

2.78 Platen Area (continued)

DETENT POSITION - F

To Check

Place typing unit in single line feed condition.

Requirement

When operated by finger pressure, line feed pawl should fully seat in platen ratchet without interference from teeth.

To Adjust

Early Design (typing units equipped with TP181030 bracket)

Loosen clamp nut (1). Position platen detent pawl pivot. Tighten clamp nut.

Late Design (typing units equipped with TP185796 bracket)

Loosen clamp nuts (2) and (3). Position platen detent pawl. Tighten clamp nuts.

Related Adjustments

Affects

LINE FEED DRIVE LINK POSITION - F
(2.82)

Affected By

VERTICAL TYPE ALIGNMENT - F
(2.71)

LINE FEED SELECTION - F (2.77)

Note: This adjustment is affected by VERTICAL TYPE ALIGNMENT - F (2.71) only when equipped with TP180526 nonadjustable vertical drive bail.

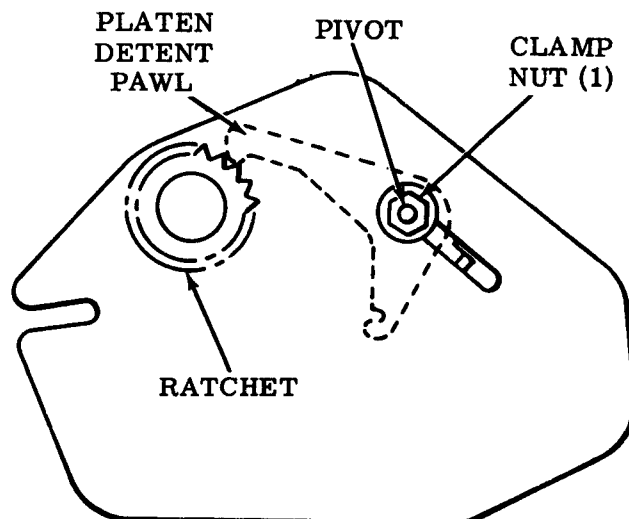

EARLY DESIGN
(Right Side View)

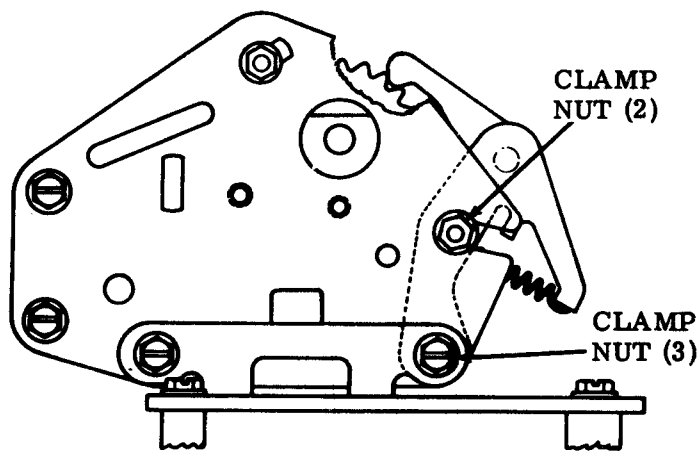

LATE DESIGN
(Left Side View)

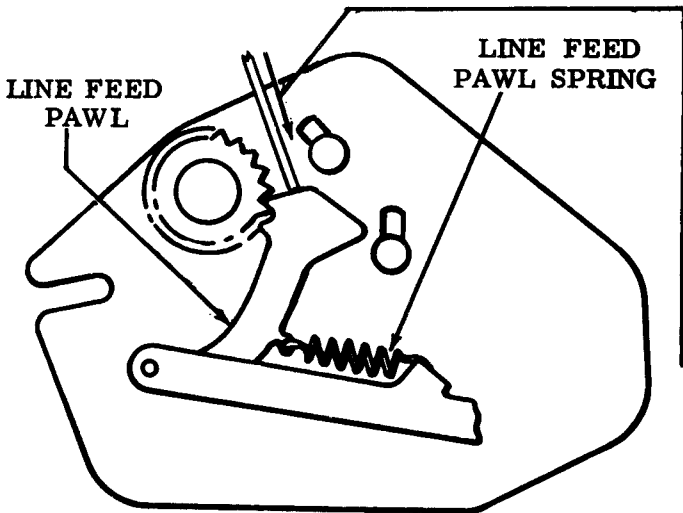

(Right Side View)

LINE FEED PAWL SPRING - F

Requirement

With typing unit in stop condition
— Min 3/4 oz---Max 1-3/4 oz
to start line feed pawl moving.

2.79 Platen Area (continued)

LINE FEED DRIVE LINK SPRING - VERTICAL - F

Requirement
With typing unit in stop condition
Min 6 oz---Max 9 oz
to start line feed drive link moving.

LINE FEED BLOCKING LEVER SPRING - F

To Check
Set up any code combination in the selector except the line feed code combination and rotate the main shaft until the function bail is at highest point. Hold line feed drive link away from line feed blocking lever.

Requirement
Min 2-1/2 oz---Max 4-1/4 oz
to start line feed blocking lever moving.

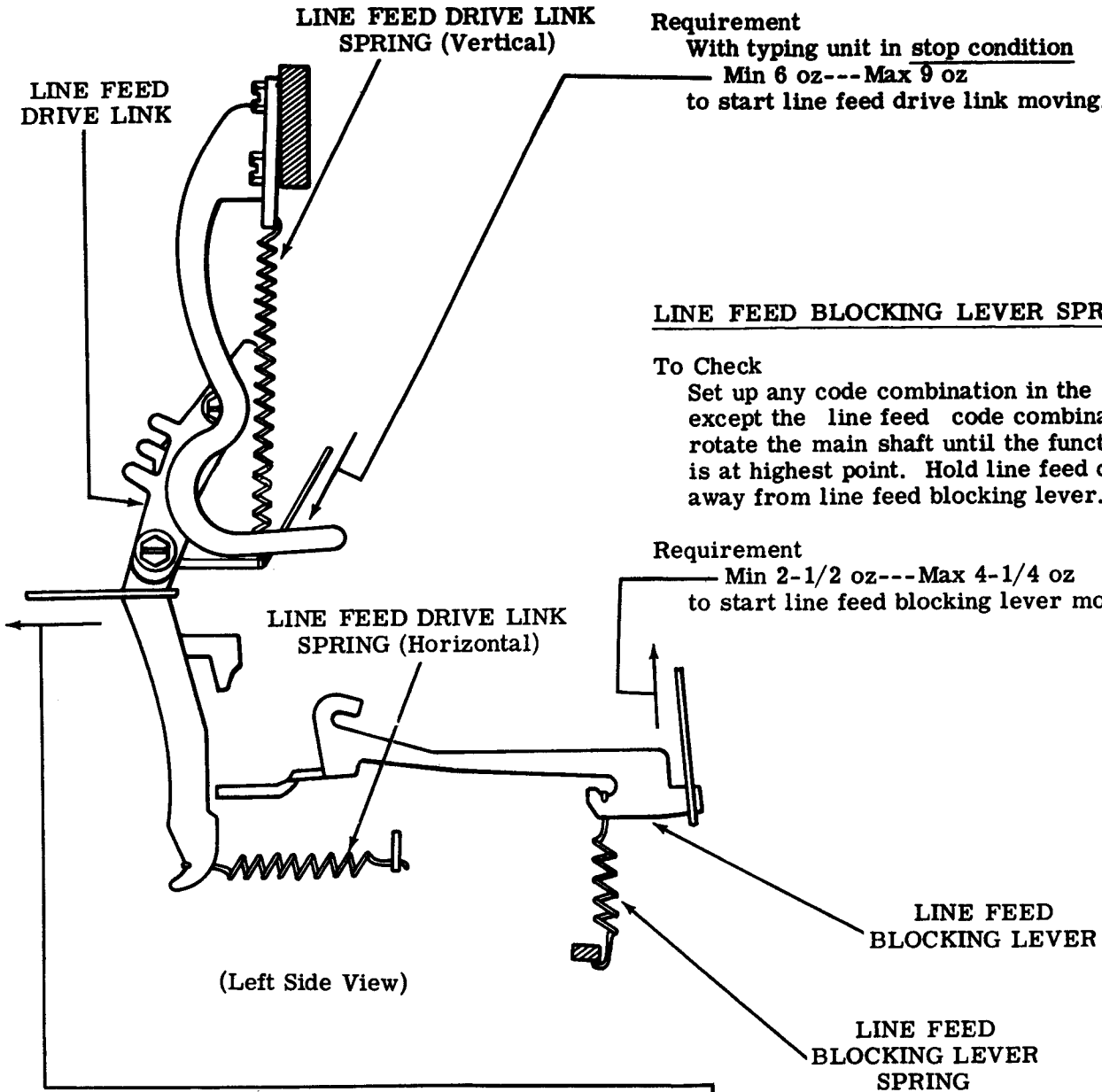

(Left Side View)

LINE FEED DRIVE LINK SPRING - HORIZONTAL - F

Requirement
With typing unit in stop condition
Min 5-1/2 oz---Max 8-1/2 oz
to start line feed drive link moving.

2.80 Platen Area (continued)

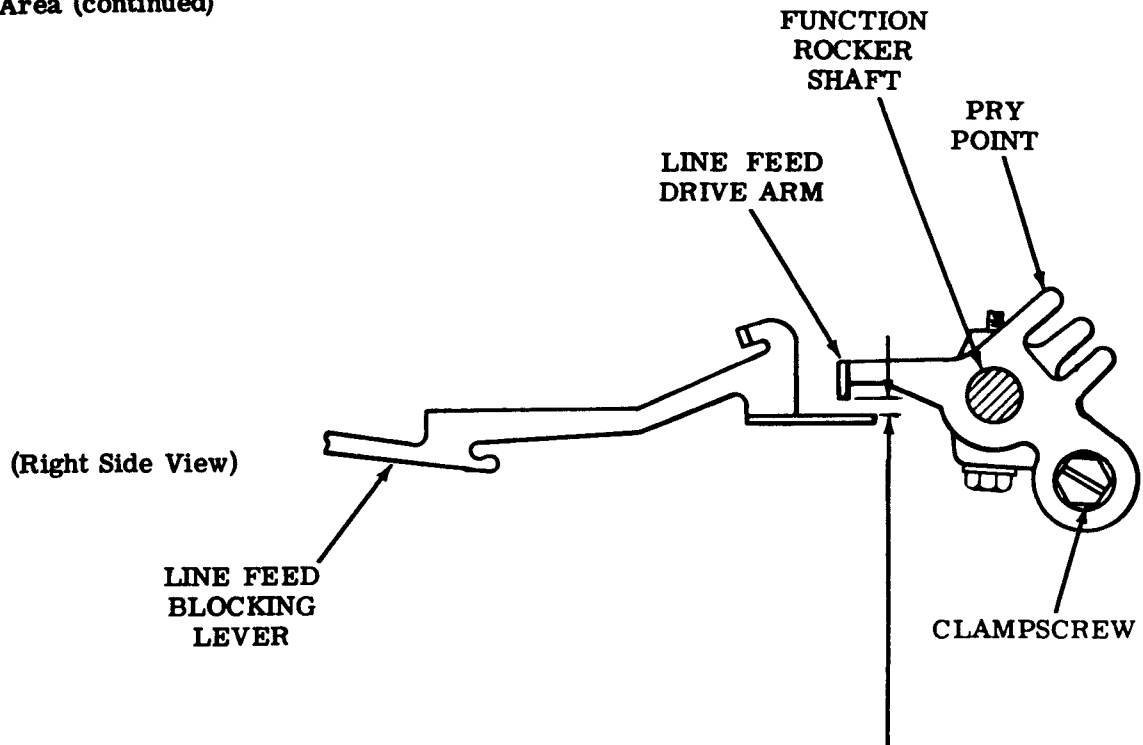
LINE FEED DRIVE ARM CLEARANCE - F**To Check**

Place carriage to center of platen. Manually operate typing unit and set up line feed code combination (-2-4---8) in selector. Rotate main shaft until function bail is at highest point. Take up play to make clearance between line feed blocking lever and line feed drive arm a minimum.

Requirement

Min some---Max 0.010 inch
between line feed drive arm and line feed blocking lever.

Note: The minimum requirement (some) will be considered met if there is no clearance between the line feed function lever and the function drive bail.

To Adjust

Loosen clampscrew. Position line feed drive arm using pry point. Tighten clampscrew.

Related Adjustments**Affects**

LINE FEED UPSTOP BRACKET POSITION - F (2.81)
LINE FEED PAWL DOWNSTOP POSITION - F (2.83)

Affected By

LEFT ROCKER DRIVE (Function Area)(2.34)

2.81 Platen Area (continued)

LINE FEED UPSTOP BRACKET POSITION - F

To Check

Place typing unit in stop condition.
 Trip function clutch by lifting its
 trip lever. Rotate main shaft until
 function bail is at highest point.
 Push down on line feed drive link
 to engage and latch line feed blocking
 lever.

Requirement

Min 0.020 inch---Max 0.040 inch
 between line feed drive arm and line
 feed blocking lever.

To Adjust

Loosen mounting screws and position
 line feed upstop bracket. Tighten
 mounting screws.

Related Adjustments

Affected By

VERTICAL TYPE ALIGNMENT - F
 (2.71)

LINE FEED DRIVE ARM CLEARANCE - F
 (2.80)

Note: This adjustment is affected by
VERTICAL TYPE ALIGNMENT - F
 (2.71) only when equipped with
 TP180526 nonadjustable vertical
 drive bail.

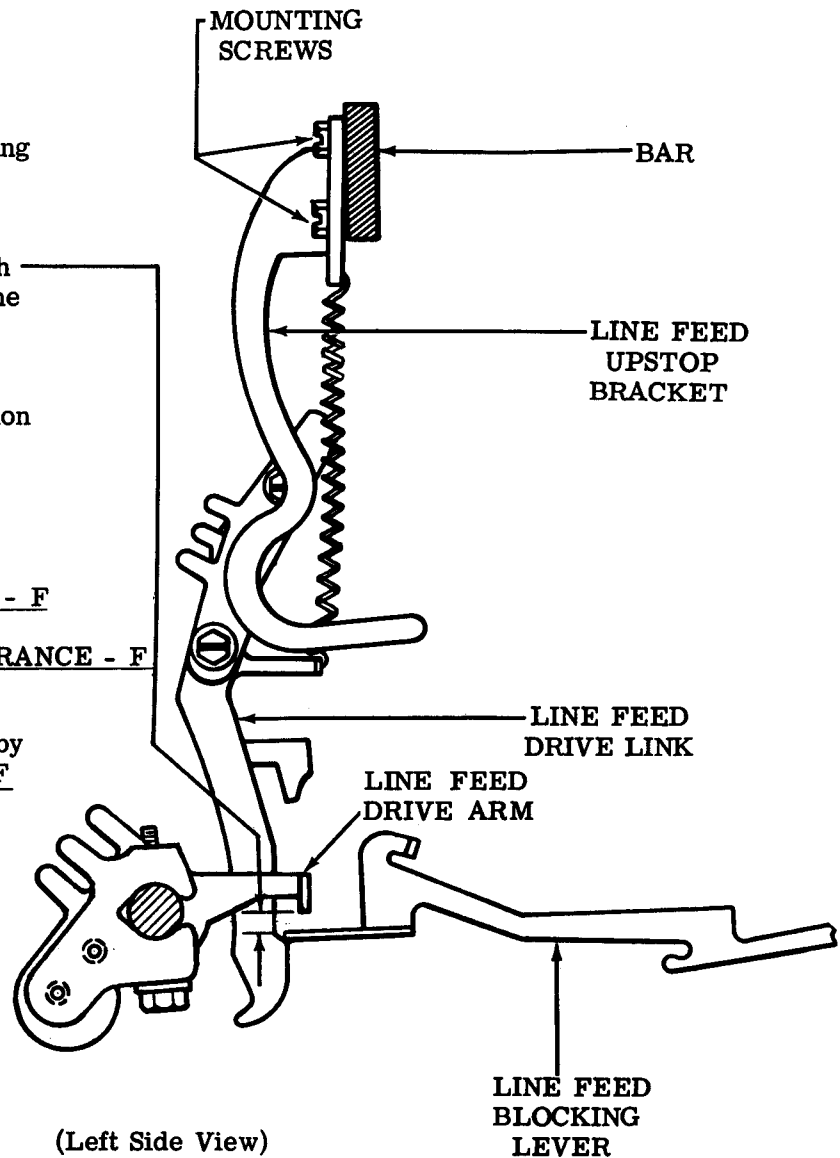

2.82 Platen Area (continued)

LINE FEED DRIVE LINK POSITION - F

To Check

Place the carriage to the center of the platen. Place the flat surface on left side of platen up and horizontally to base casting, and set up the line feed code combination (-2-4---8) in the selector. Rotate main shaft until function bail reaches its lowest point while noticing the motion supplied by the drive arm of the function rocker shaft to the line feed pawl.

(1) Requirement

The motion supplied by the drive arm of the function rocker shaft to the line feed pawl should be adequate to rotate the platen the required amount.

(2) Requirement

Hold platen detent pawl away from ratchet and rotate main shaft until function bail is in its lowest position. Lower platen detent pawl into its seat between two ratchet teeth. The platen should barely move.

To Adjust

Loosen line feed stripper plate clampscrew and back off line feed stripper plate (see LINE FEED STRIPPER PLATE CLEARANCE adjustment). Loosen downstop nut friction tight (2.83). Loosen two clampscrews and use pry points to position line feed drive link so that line feed pawl indexes platen one tooth and platen detent pawl seats fully in ratchet. Tighten clampscrews.

Related Adjustments

Affects

LINE FEED PAWL DOWNSTOP POSITION - F (2.83)

Affected By

DETENT POSITION - F (2.78)

VERTICAL TYPE ALIGNMENT - F (2.71)

PLATEN DETENT PAWL SPRING - F

Requirement

Early Design

Min 24 oz---Max 30 oz

Late Design

Min 31 oz---Max 37 oz

to start platen detent pawl moving.

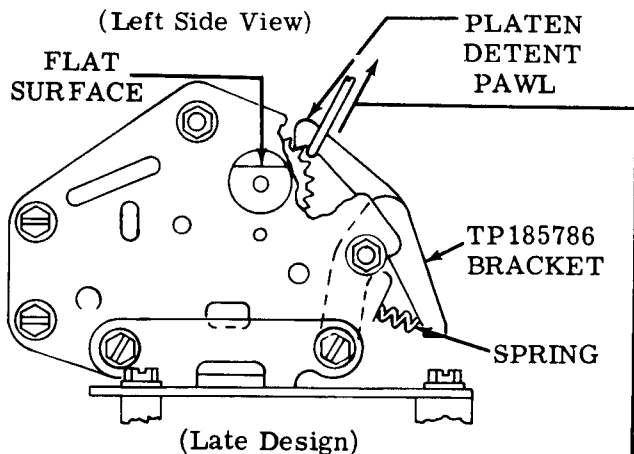
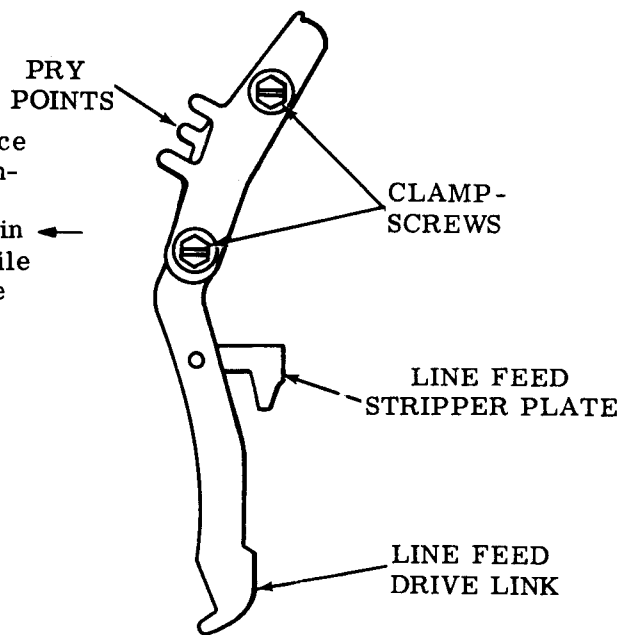

(Left Side View)

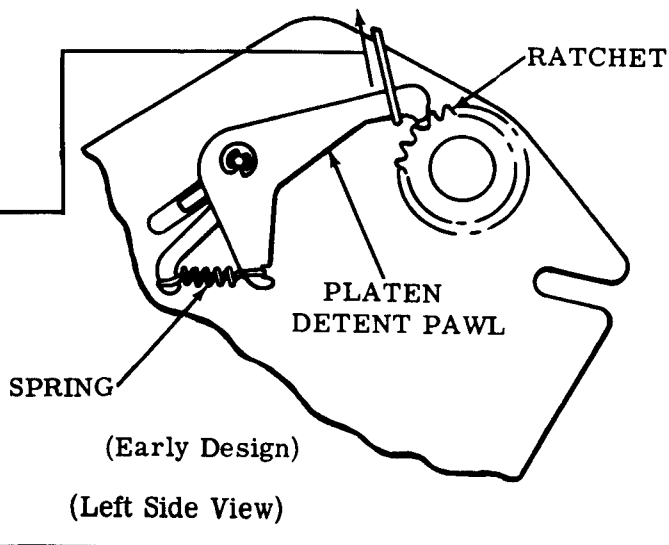

(Left Side View)

2. 83 Platen Area (continued)

LINE FEED PAWL DOWNSTOP POSITION - F

To Check

Place the flat surface on the left side of platen up and horizontal to base casting. Set up the line feed code combination (-2-4---8) in the selector. Rotate main shaft until function bail reaches its lowest position. Take up play of platen in left end plate toward the rear.

Requirement

With platen detent pawl fully seated in ratchet

Min 0.005 inch---Max 0.015 inch
Between back of line feed pawl and its downstop.

To Adjust

Loosen downstop clamp nut. Position downstop. Tighten clamp nut.

Related Adjustments

Affected By

LINE FEED DRIVE ARM CLEARANCE - F (2.80)

LINE FEED DRIVE LINK POSITION - F (2.82)

VERTICAL TYPE ALIGNMENT - F (2.71)

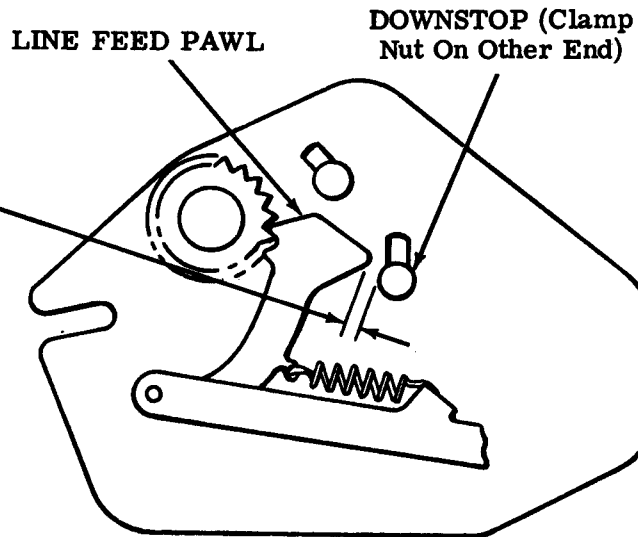

(Right Side View)

2.84 Platen Area (continued)

PRESSURE ROLLER CLEARANCE

To Check

Position carriage with lock bracket left mounting screw directly under pressure roller. Release pressure roller (pressure lever placed in forward position).

Requirement

Min 0.010 inch between pressure roller and left mounting screw.

Note: Clearance should not be so large that roller is not detented in released position.

To Adjust

Loosen clampscrew. Position pressure roller adjusting bracket. Tighten clampscrew.

Related Adjustment

Affected By

- REAR RAIL POSITION (Carriage Area) (2.45)
- VERTICAL TYPE ALIGNMENT - F (2.71)

Note: This adjustment is affected by VERTICAL TYPE ALIGNMENT - F (2.71) only when equipped with TP180526 nonadjustable vertical drive bail.

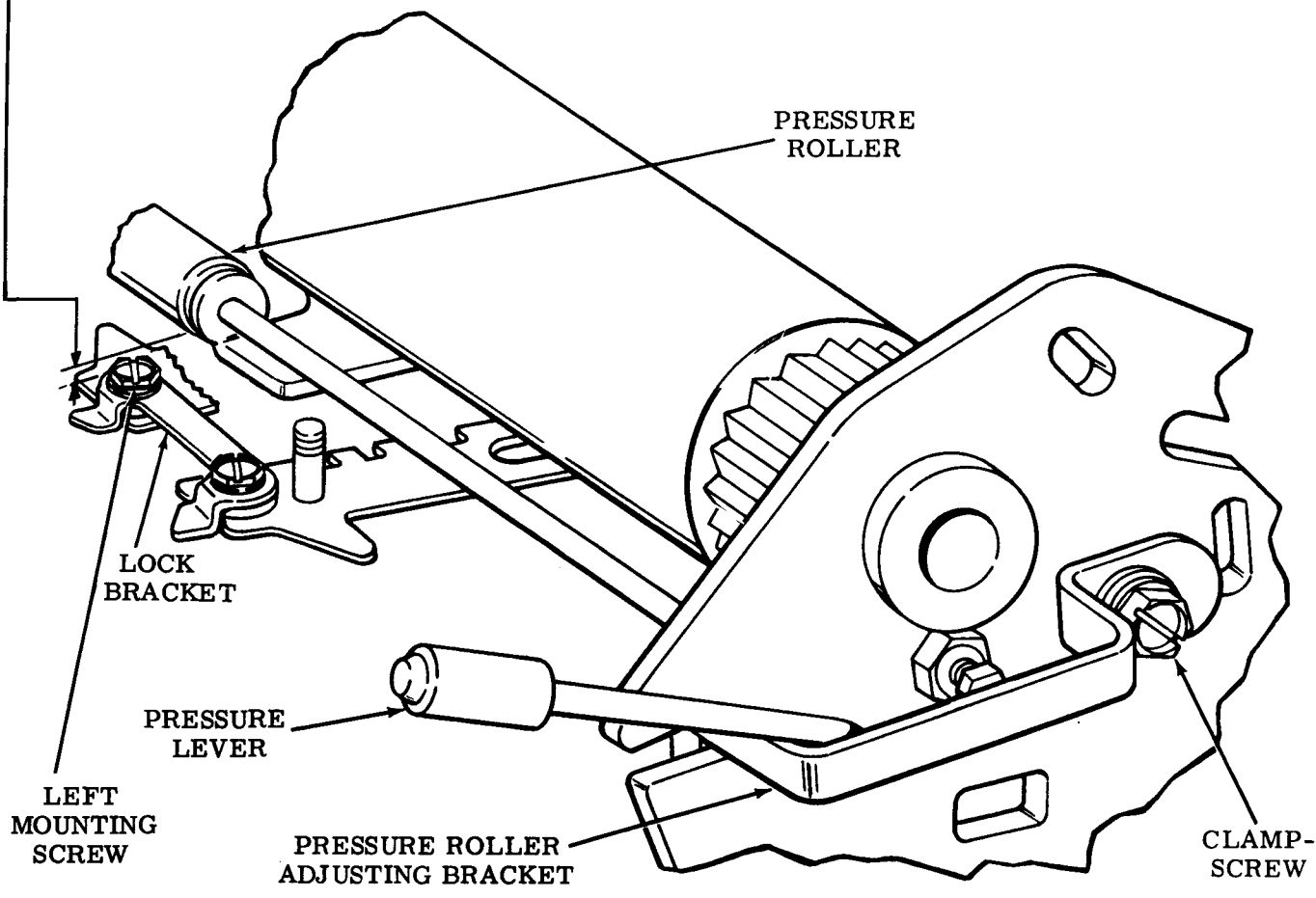

(Right Front View)

2.85 Platen Area (continued)

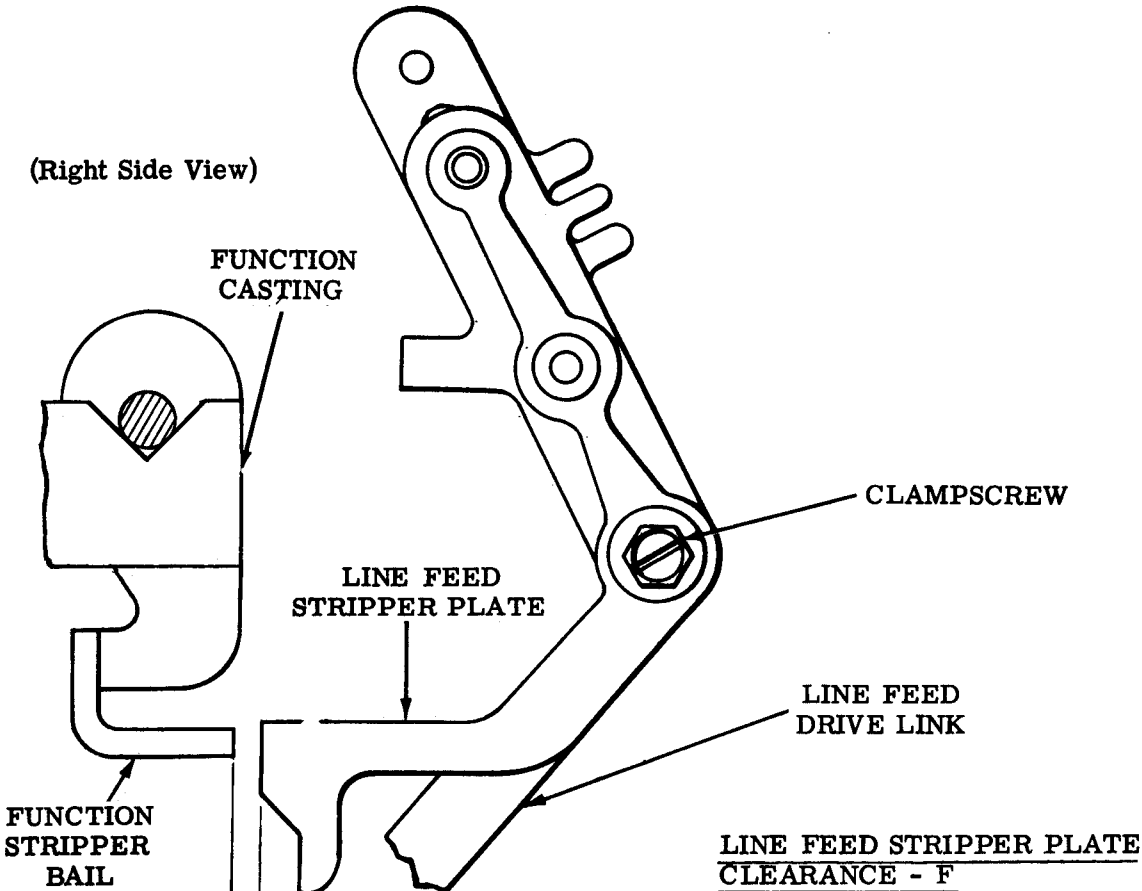

LINE FEED STRIPPER PLATE CLEARANCE - F

To Check

Set up the line feed code combination (-2-4---8) in the selector. Rotate the main shaft until function bail reaches its lowest point. Hold line feed drive link firmly against line feed blocking lever.

(1) Requirement

The line feed stripper plate should be Min some---Max 0.005 inch away from function stripper bail.

(2) Requirement

The line feed blocking lever and line feed drive link should fully engage.

To Adjust

Loosen clampscrew. Position line feed stripper plate. Tighten clampscrew.

Related Adjustments

Affected By

STRIPPER BAIL CLEARANCE (2.38)
PLATEN — HORIZONTAL
POSITION - F (2.70)

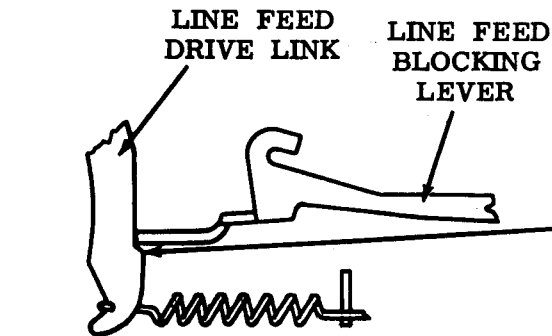

(Left Side View)

2.86 Platen Area (continued)

COPYHOLDER WIRE POSITION - F

(1) Requirement

The copyholder wire should fall somewhere between two lines of printed copy, not obscuring more than $1/2$ the height of either line.

To Adjust

Loosen four mounting screws. Position copyholder wire. Tighten screws.

(2) Requirement

After raising and releasing, the copyholder wire should return and rest against the platen at its center with a maximum of 0.020 inch between platen and copyholder wire at both the left and right ends.

To Adjust

Bend copyholder wire.

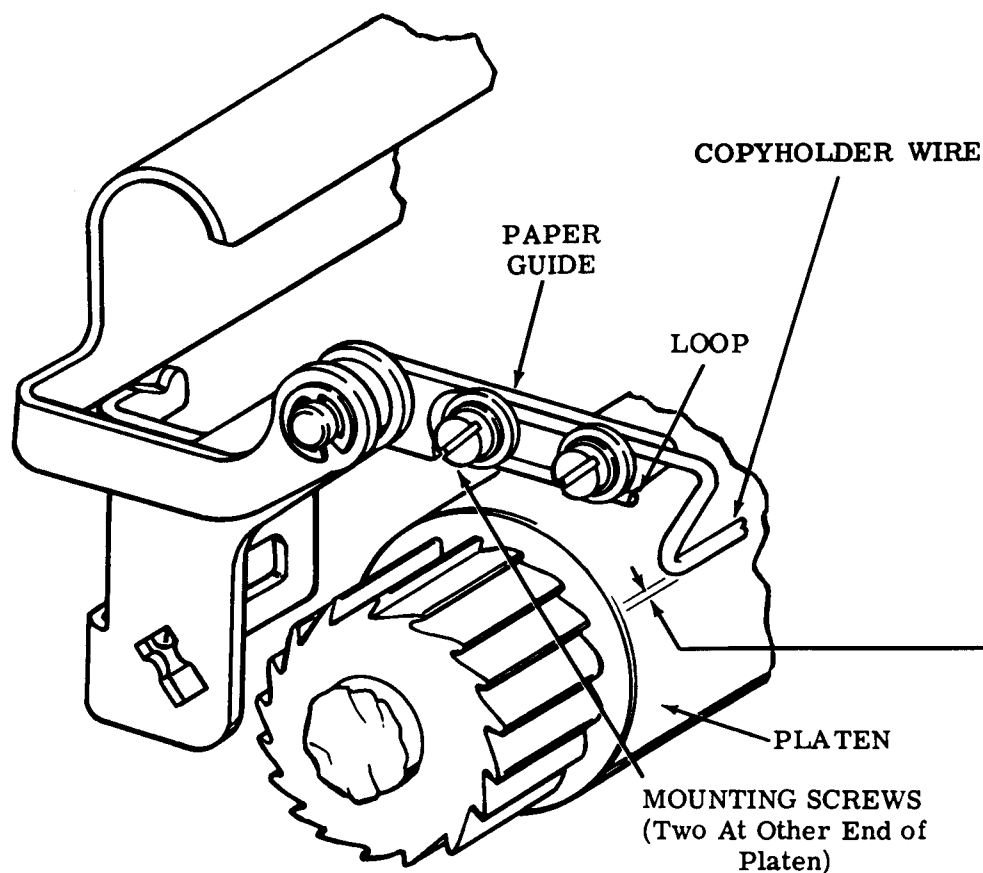

(Left Side View)

2.87 Platen Area (continued)

PAPER GUIDE SPRING - S

Requirement

With paper guides resting on platen

Min 16 oz---Max 18 oz to pull each paper guide spring to installed length.

PAPER GUIDEPLATE SPRING - S

Requirement

With a spring scale positioned at middle of paper guideplate

Min 3-1/2 oz---Max 7-1/2 oz to start paper guideplate moving.

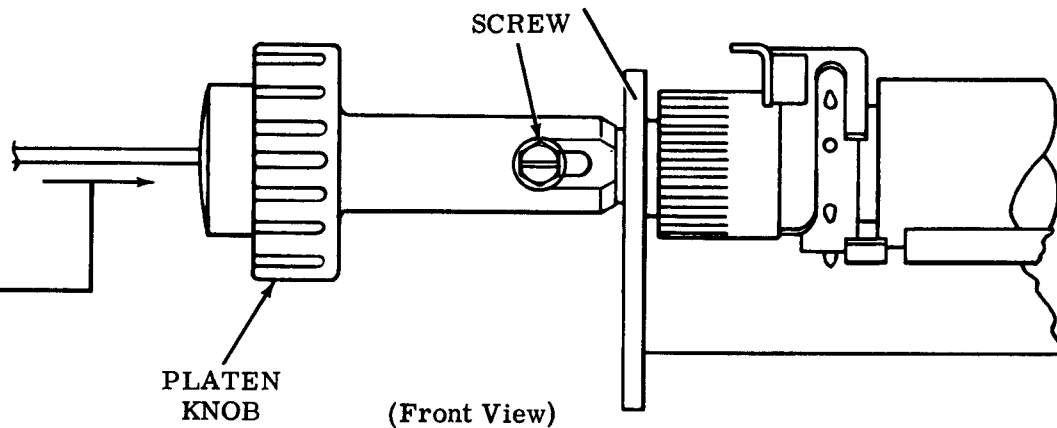
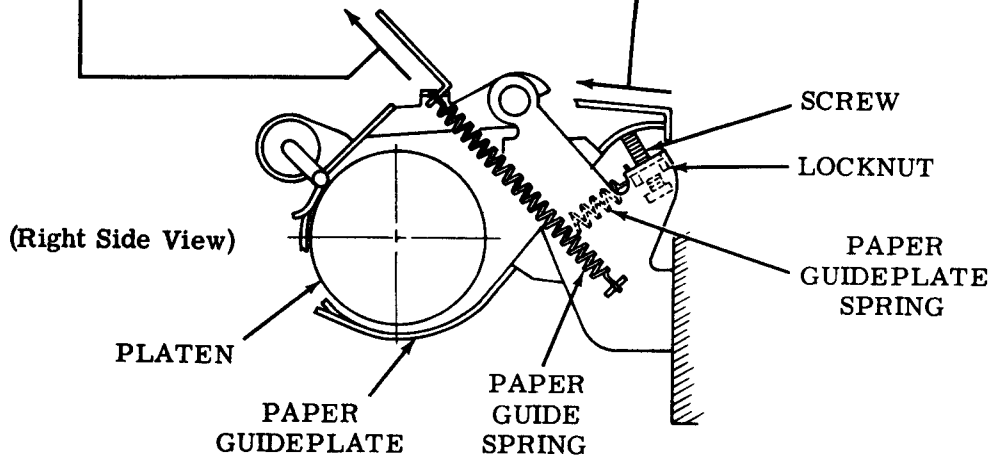

PLATEN KNOB SPRING - S

Requirement

With a spring scale positioned on platen knob

Min 15 oz---Max 23 oz to start platen knob moving.

PLATEN KNOB POSITION - S

Requirement

The platen knob should be fully seated toward the right.

To Adjust

When typing unit is on its subbase and cover is installed, loosen screw and position platen knob. Tighten screw.

2.88 Platen Area (continued)

PLATEN ENDPLAY - F

Note: This adjustment applies only to typing units equipped with TP185816 adjusting screw.

To Check
Position platen against the left end plate.

Requirement
Min 0.002 inch---Max 0.015 inch
between the TP185816 adjusting screw and the right end of the platen.

To Adjust
Loosen the locknut. Position platen against the left end plate. Position the TP185816 adjusting screw. Tighten locknut.

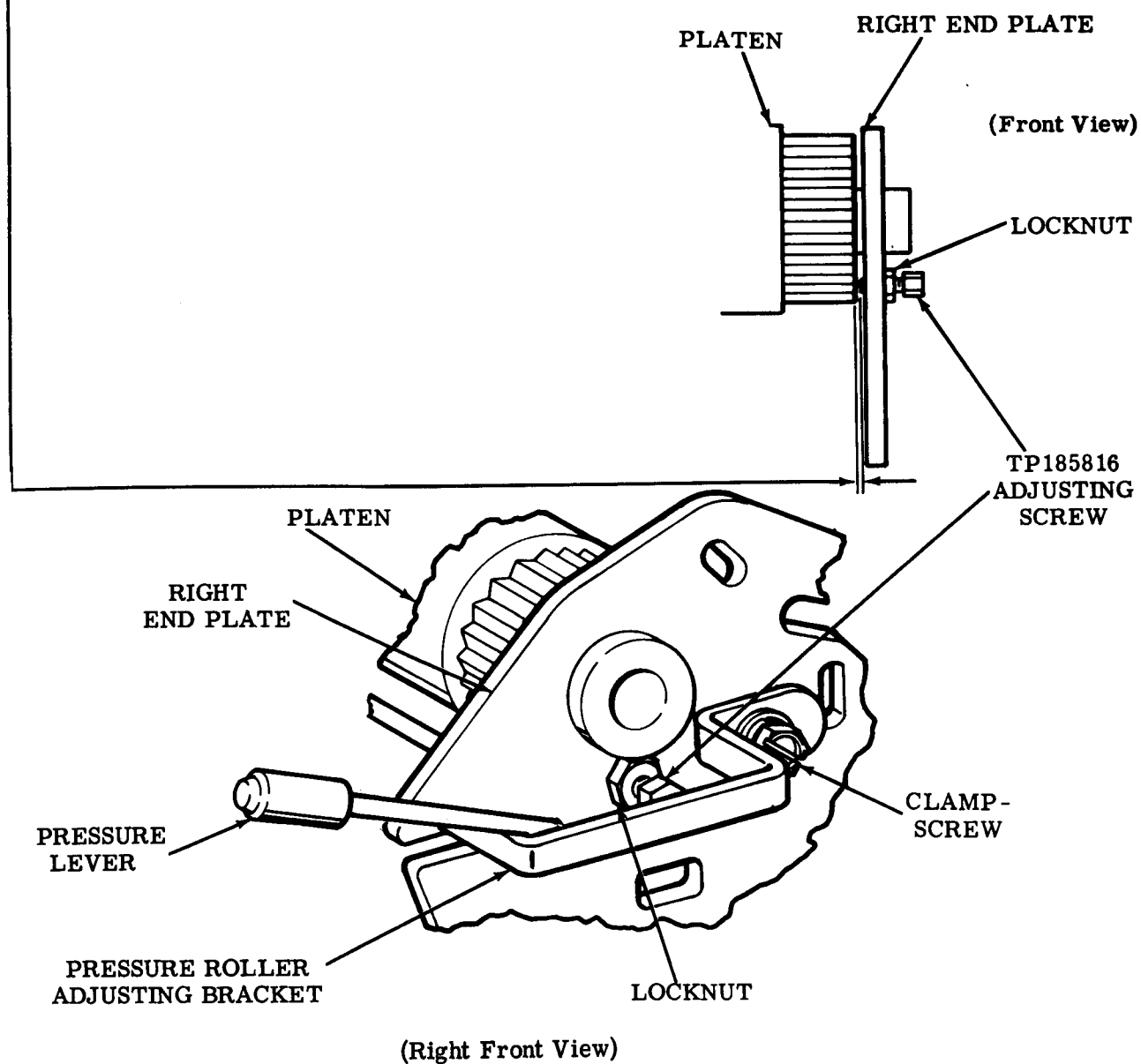

2.89 Platen Area (continued)

Note 1: If the idler has not previously been backed off, loosen the nut securing the idler post and position idler to low point in slot before making the following adjustment.

PLATEN – HORIZONTAL POSITION - S

(1) To Check

Place the platen knob screw up and permit the detent ratchet pawl to seat in a groove of the detent ratchet. Place the carriage at the left margin and check requirement. Move the carriage to the right margin and again check requirement.

Requirement

Min 0.050 inch---Max 0.065 inch
between ribbon guide and platen at both left and right margins.

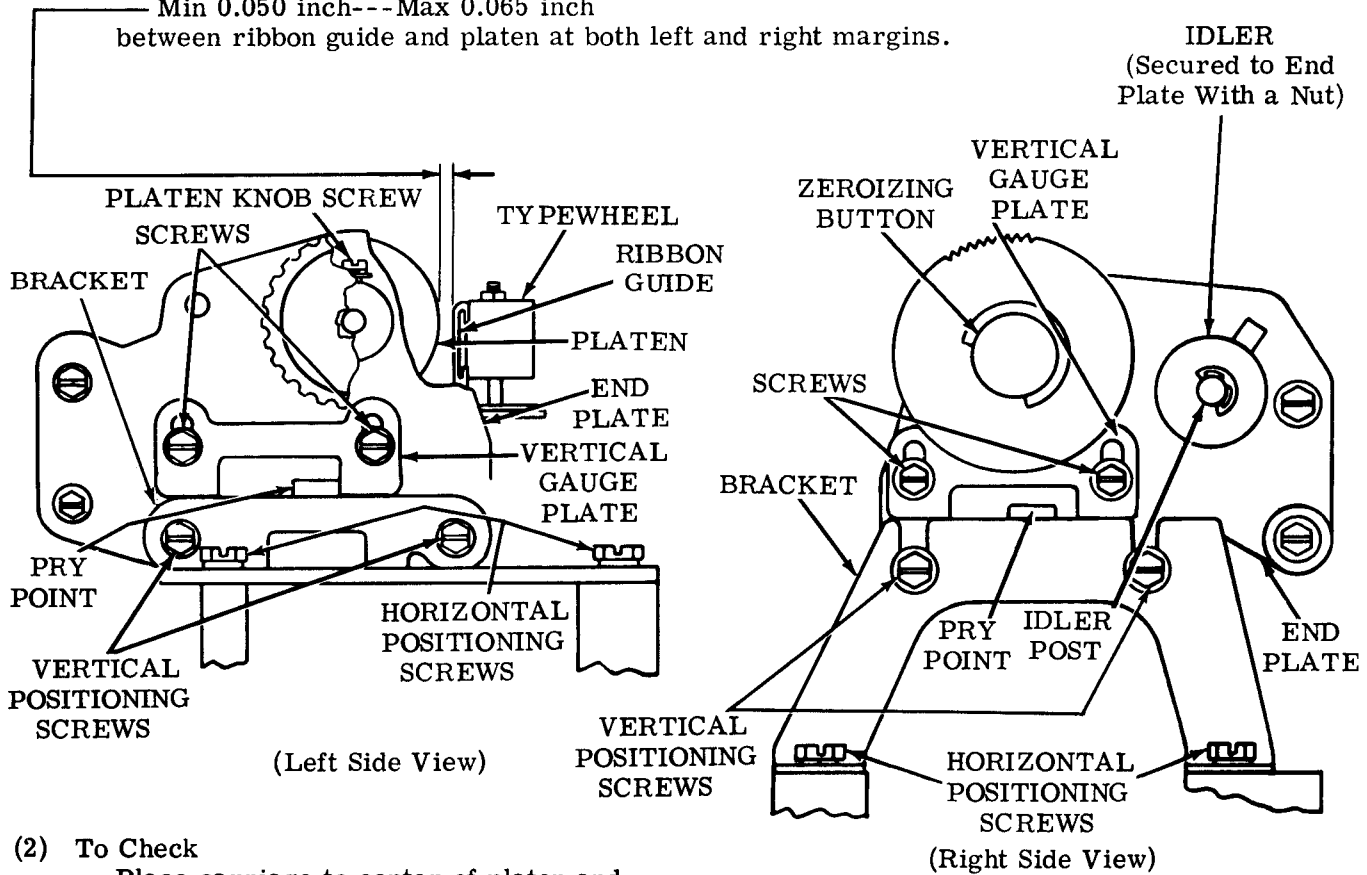

(2) To Check

Place carriage to center of platen and rotate platen until maximum clearance is obtained between platen and ribbon guide. Set up E code combination (1-3---78) in the selector. Rotate main shaft until carriage drive bail is in its rearmost position. Push typewheel to the rear until it just touches the platen.

Note 2: The typing unit should not have sprocket forms or ribbon installed.

Requirement

Typewheel should not touch side of either ribbon guide.

Related Adjustments

Affected By

FRONT ROLLERS CLEARANCE (2.43)

2.90 Platen Area (continued)

PLATEN — HORIZONTAL POSITION - S (continued)**To Adjust**

Loosen four horizontal positioning screws. Position platen horizontally. Tighten the four horizontal positioning screws.

Related Adjustments**Affects**VERTICAL TYPE ALIGNMENT - S (2.90)FORM FEED BELT TENSION - S (2.94)IDLER POSITION - S (2.100)CAM ZERO POSITION (2.110)DETENT POSITION - S (2.109)WIRE GUIDE POSITION - S (2.117)

Note: If the idler has not previously been backed off, loosen the nut securing the idler post and back off the idler before making the VERTICAL TYPE ALIGNMENT - S (2.90) adjustment.

VERTICAL TYPE ALIGNMENT - S

Typing units equipped with adjustable vertical drive bail such as TP180606:

(1) To Check

Place carriage to left margin. Set up the E code combination (1-3---78) in the selector and rotate the main shaft until the character is printed.

Requirement

When the printed character is examined by eye from top to bottom, the shading should be approximately the same with no overscoring or underscoring.

To Adjust

Loosen adjusting screw on vertical drive bail and position the typewheel using pry point.

(2) To Check

Place carriage to right margin. Set up the E code combination (1-3---78) in the selector and rotate main shaft until the character is printed.

Requirement

When the printed character is examined by eye from top to bottom, the shading should be approximately the same with no overscoring or underscoring.

To Adjust

Loosen the vertical gauge plate screws on the right side of the platen mechanism and back off the vertical gauge plate. Loosen vertical positioning screws on right side. Position the right end of the platen using pry point. Do not twist the platen. After adjusting, position the vertical gauge plate on the right side so that it is resting on its associated bracket. Tighten all screws.

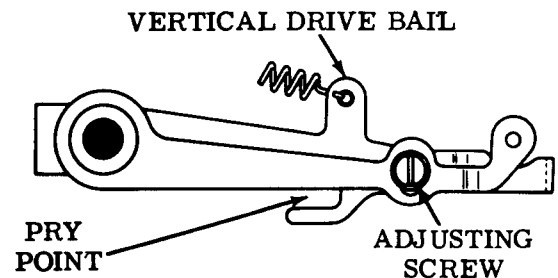
**(Right Side View)**

2.91 Platen Area (continued)

VERTICAL TYPE ALIGNMENT - S (continued)

Typing units equipped with nonadjustable vertical drive bail such as TP180526:

To Check

Place paper in typing unit. Set up the E code combination (1-3---78) in the selector and rotate the main shaft until the character is printed. Repeat several times along the length of the platen.

Requirement

When each printed character is examined by eye from top to bottom, the shading should be approximately the same with no overscoring or underscoring.

To Adjust

Loosen the vertical gauge plate screws and back off the vertical gauge plate on each side of the platen mechanism. Loosen four vertical positioning screws and position the platen using pry points. Do not twist the platen. After adjusting, position each vertical gauge plate so that it is resting on the top of its associated bracket. Tighten all screws.

Related Adjustments

Affects

IDLER POSITION - S (2.100)
DETENT POSITION - S (2.109)
CAM ZERO POSITION (2.110)
WIRE GUIDE POSITION (2.117)

Affected By

PLATEN — HORIZONTAL POSITION - S (2.89)
REAR RAIL POSITION (2.45)
PRINT DRIVE LEVER POSITIONING (2.48)

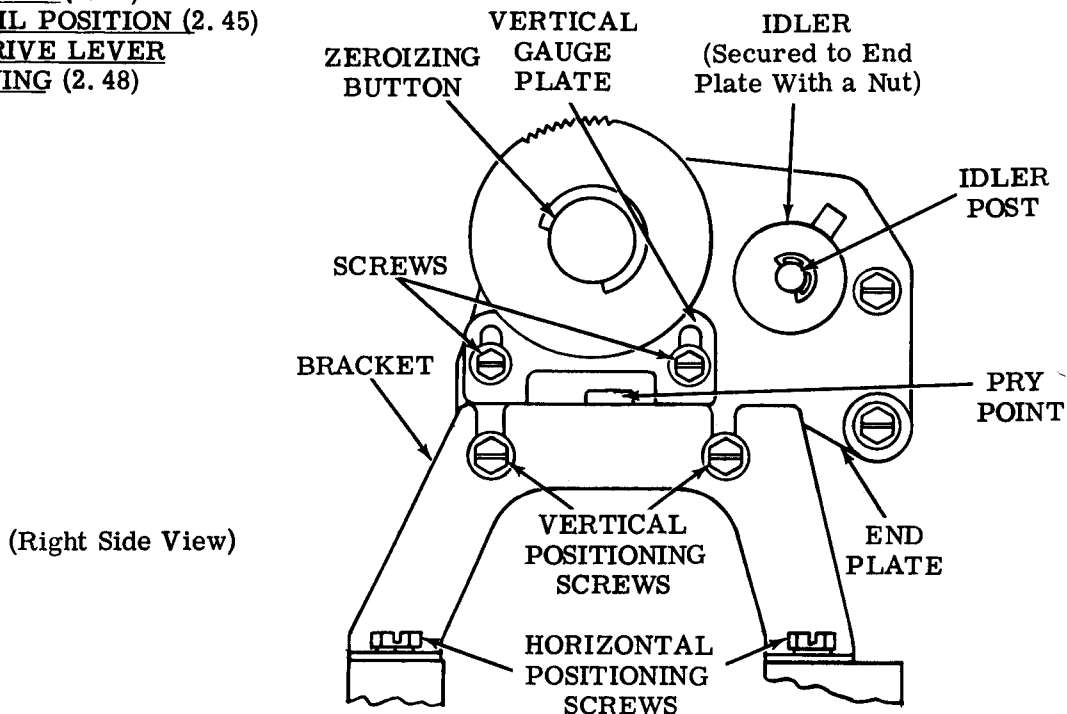

2.92 Platen Area (continued)

PAPER GUIDEPLATE CLEARANCE - S

Requirement

With no sprocket forms in the platen mechanism

Min 0.008 inch---Max 0.025 inch between the platen and the left and right ends of the paper guideplate adjacent to the fingers. Record the two clearances (see Note 2).

To Adjust

Loosen locknut and adjust screw. Tighten locknut.

Note 1: If the adjustment cannot be made as indicated above, remove the platen mechanism from the typing unit. For instructions, see appropriate disassembly and reassembly section. Then, preliminary adjust as follows:

Preliminary Requirement

With the screw backed off and no sprocket forms in the platen mechanism

Min zero---Max 0.012 inch between the platen and the left and right ends of the paper guideplate — adjacent to the fingers. Record the two clearances (see Note 2).

Preliminary Adjust

Loosen end plate screws friction tight and position end plates. Tighten screws.

Note 2: The fingers at both the left and right ends of the platen should be Min some---Max 0.015 inch beyond the recorded gap between the platen and the left and right ends of the paper guideplate. Bend fingers to meet the requirement.

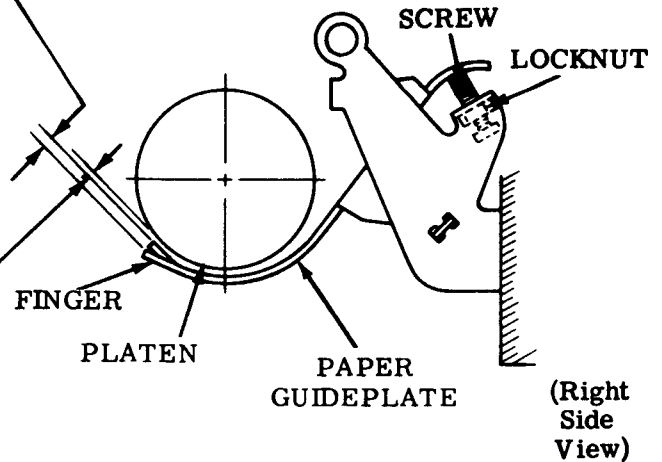

Note 3: Replace platen mechanism onto the typing unit. For instructions see appropriate disassembly and reassembly section. Check requirement.

Related Adjustments

Affects

PAPER ALARM CONTACT LEVER CLEARANCE - S (2.119)

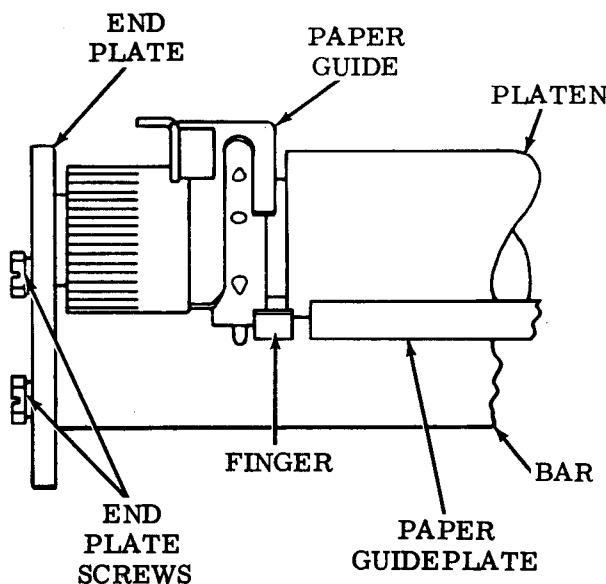

2.93 Main Shaft Area (continued)

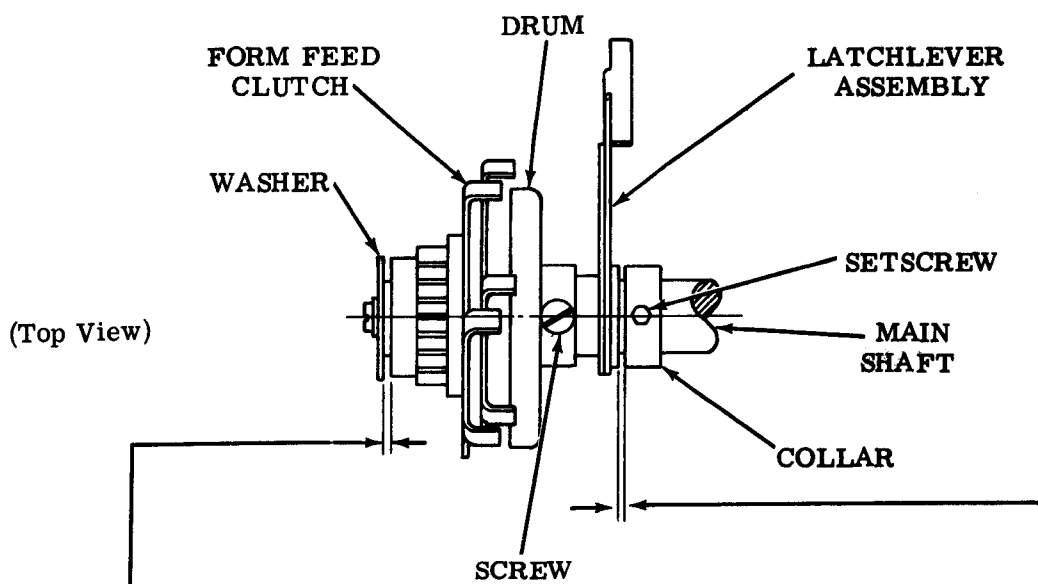

(A) FORM FEED CLUTCH ENDPLAY - S

Requirement

Min some---Max 0.012 inch
endplay between washer and form
feed clutch.

To Adjust

Loosen drum screw and position drum.

(B) LATCHLEVER ENDPLAY

Requirement

Min some---Max 0.012 inch
endplay between latchlever assembly and collar.

To Adjust

Loosen setscrew and position collar.
Tighten screw.